

The Intelligent Simplicity



# Sentron 3WL

**Air Circuit Breaker**

Answers for industry.

**SIEMENS**



## “SENTRON - Intelligent Simplicity”

*In essence, modularity means: User-friendly ease of planning, multiple use of standard configurations - also, simple management of changes and modification on site*

## The Art of Intelligent Simplicity - Sentron WL

Circuit Breakers today are no longer simple switching and protecting devices with ON/OFF and trip indications. Users today are looking at circuit breakers as a device, which integrates switching, protection, metering and power management including quality of power from remote locations. Modern power systems are also characterized by the methods used to network circuit breakers - both with each other and with other components.

Siemens offers SENTRON WL family, which have a lot more to offer than even the so-called “new circuit breaker” in the market. In future, it will not only be possible to carry out diagnosis and maintenance procedures remotely on the Internet, but real-time information about system malfunctions and alarm signals will be made available immediately to operating staff through SMS and mobile phones.

**This is not a fantasy for the future; in fact it's hard reality.**

This is Sentron. A new generation of circuit breakers from 100 A to 6300 A available in three different sizes with the following advantages.

### Intelligent Modularity with Cost Savings:

- Same internal and external accessories for the entire range reducing inventory cost.
- Compact in size. A 6300 A 3WL requires only 800mm wide cabinet.
- Practically no deration till 55 Deg C with the permissible service temperature upto 70 Deg C. A 5000 A 3WL can deliver 5000 Amp even at 70 Deg C.
- High electrical life reduces the frequency of replacement of contacts.
- Unique rating plug facility allows a 3200 Amp 3WL to have thermal overload setting as low as 100A. This ensures complete protections even when the system is partially loaded.
- Integrated CubicleBUS provides unmatched flexibility and cost economic solutions to all panels - metering, protections and annunciations requirements.
- Sentron stands for complete energy management - solution for continuous energy cost supervision and optimization - in short intelligent savings.



*Whether for rapid retrofitting, reduced handling or optimal energy management- anybody choosing SENTRON will profit from clear and definite economic*

### Easy Planning:

- Sentron WL is available in three frame sizes yet with identical door cutouts for all the frames and at same locations on the breakers to ensure standardization, symmetry and aesthetics in panel design.
- Software such as 'SIMARIS' designed to support you with evaluation, planning and calculation of the entire system, thus saving considerable time and energy in designing an electrical system.
- Contact erosion indicator on the main contacts will help to plan shutdown for the contact maintenance.
- 3 breakers frame size, 3 breaking capacity, single family and modular construction allows optimum selection of breaker.

### Maximum Safety:

- Distinct mechanical Ready-to-close indicator is provided as an inherent safety feature. This ensures safe switching ON of ACB and eases the diagnosis. Ready-to-close interlocking will verify the following condition:
  - 3WL is switched OFF
  - Storage spring is charged
  - Undervoltage released is energized
  - Shunt trip not energized
  - Closing coil not energized
- No external interlocks activated
- Mechanical reclosing lockout reset

- Crank release lever ensures breaker removal from the guide frame only when the contacts are separated.
- SAFE LOCK suitable for isolation. Castell key can be removed only when the contacts are separated.
- Lockable guide frame on removal of circuit breaker available as standard.
- Lockable withdrawable circuit breaker to protect against unauthorized removal provided as a standard.
- High degree of IP protection class upto IP 55
- Mechanical reclosing lock out after overload or short-circuit release provided as standard feature.
- The front cover cannot be removed if the circuit breaker is in closed condition.
- 3WL confirms to isolation requirement as per DIN EN 60 947 - 2

### System Solutions:

- The Breaker Data Adapter(BDA) with integrated Web-server allows local parameterization, operation and observation of SENTRON circuit breaker. BDA plus provides additional Ethernet interface for remote diagnosis via LAN / WAN.
- The Switch ES Power software with the same functionality via PROFIBUS - DP and with integrated object manager for integration of the SENTRON circuit breakers into SIMATIC system



Setting the benchmark:  
 With solutions based on SENTRON  
 Strong as individual products - unsurpassed  
 within communication structures:  
 SENTRON WL

and thus, the breaker can be accessed even remotely for diagnosis, parameterization and control, Important messages (e.g. Trip signal and reasons) can be transmitted by SMS to the cell phone of plant personnel.

- SENTRON WL can simultaneously exchange the data with two masters and the high transmission rate of 12 Mega bytes / sec ensures virtually real time system operations.

**Easy Operations / Easy Maintenance:**

- Innovative drawout mechanism with integral crank handle.
- Click-fit front accessories.
- Built-in test features permits testing of the breakers without any additional test kit.

**Sentron WL : A single family in three different size, from 100 to 6300 A.**

	Circuit Breaker rated current $I_n$ max (A)	Breaking Capacity $I_{cu}$ at 500 V AC (kA) or $I_{cc}$ at 300 V DC (kA)	Dimensions		
			Fixed mounted 3-/4-pole	With drawable 3-/4-pole	
Size III	6300	 H 100    C 150(3P)**	704 / 914	704 / 914	Width
	5000		434 / 434	460 / 460	Height
	4000		291 / 291	385 / 385	Depth
Size II	4000	 DC 30    N 66    S 80    H 100	460 / 590	460 / 590	Width
	3200		434 / 434	460 / 460	Height
	2500		291 / 291	385 / 385	Depth
	2000				
	1600				
	1250				
Size I	1600	 N 55    S 66	320 / 410	320 / 410	Width
	1250		434 / 434	460 / 460	Height
	1000		291 / 291	385 / 385	Depth
	800				
	630				

\* The dimension for the depth of the circuit breaker is from the circuit breaker rear to the inner surface of the closed switchgear door  
 \*\* 130(4P)

## Standards:- The Sentron WL Circuit Breakers satisfy:

- IEC 60947 - 2, IS 13947 - 2
- DIN VDE 0660 Part 101
- UL 489 / ANSI C 37.13, UL 1066
- Climate Proof according to DIN IEC 68 Part 30 - 2
- CE Conformance
- Lloyd's Register of shipping



User-friendly and precise:  
Planning with SENTRON

### 3 and 4 pole, up to 6300 A fixed - mounted and withdrawable version

#### Description

Microprocessor based electronic over-current release (ETU)

During the development of our over-current release we have consistently striven to ensure modularity. The following are just some modules that are simple to retrofit at any time

- Earth-fault protection module
- Communication modules
- Metering function
- Displays
- Rating plugs

This enables fast local adaptation to new network conditions. At the same time, the ETU are provided with new, innovative functions like:-

#### Rating Plug

The Rating Plug is a replaceable module that enables users to reduce the rated device current for optimum adaptation to the system; e.g. during startup of a plant section. The Rating Plug should be selected so that it roughly corresponds to the rated current of the system.

#### Switch-selectable $I^2t$ or $I^4t^4$ characteristic curve for the overload range.

The best possible protection for the overall switchgear assembly is achieved by ensuring optimum setting of the release characteristic. To achieve optimum selectivity of the upstream fuses or medium-voltage protective devices, the inclination of the characteristic curve can be switched over in the overload range.

#### Switch-selectable parameters

In the event of a sudden change in network conditions e.g. switchover of the transformers to generator operation or shut down of a part of the supply network at the change of shift, SENTRON WL now supports fast adaptation of the required protective parameters to the new circumstances. Two release characteristics (parameter sets) that are independent of one another are stored on the ETUs. The transfer is executed in under 100ms and is initiated by an external signal.

### Overcurrent release ETU 45B

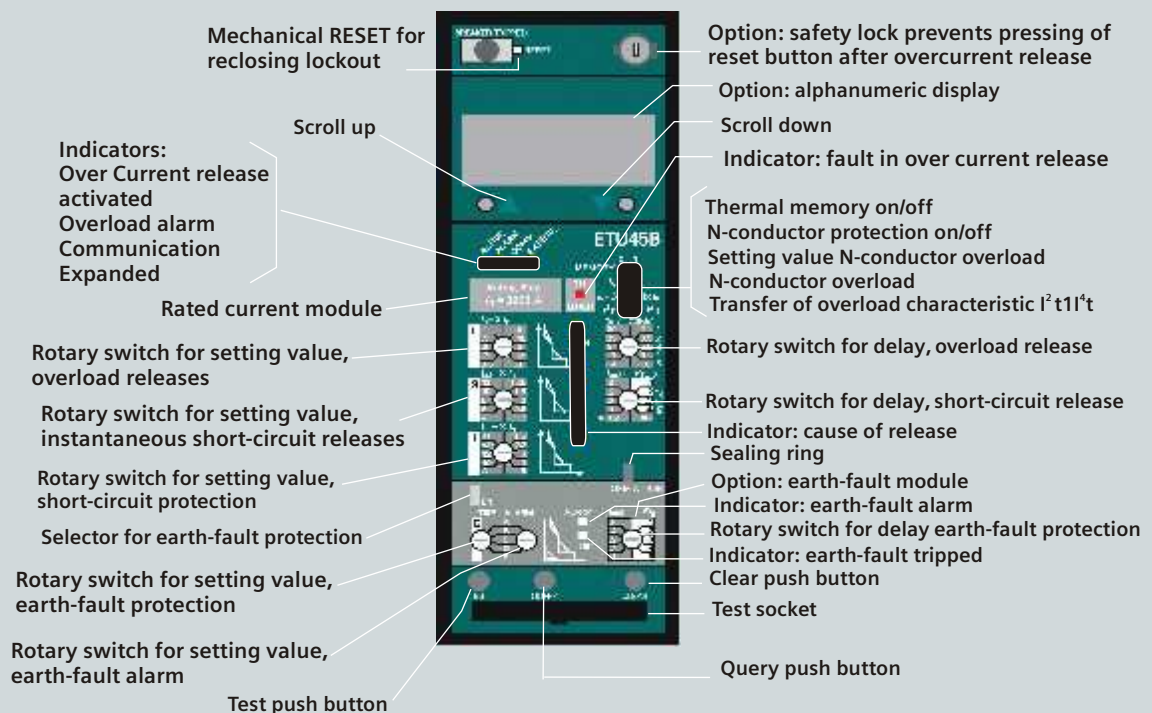

## Rating Plug-in

size I	size II	size III
250A	250A	
315A	315A	
400A	400A	
500A	500A	
630A	630A	
700A	700A	
800A	800A	
1000A	1000A	
1250A	1250A	1250A
1600A	1600A	1600A
	2000A	2000A
	2500A	2500A
	3200A	3200A
		4000A
		5000A
		6300A

## Sample configuration of an ETU 45B

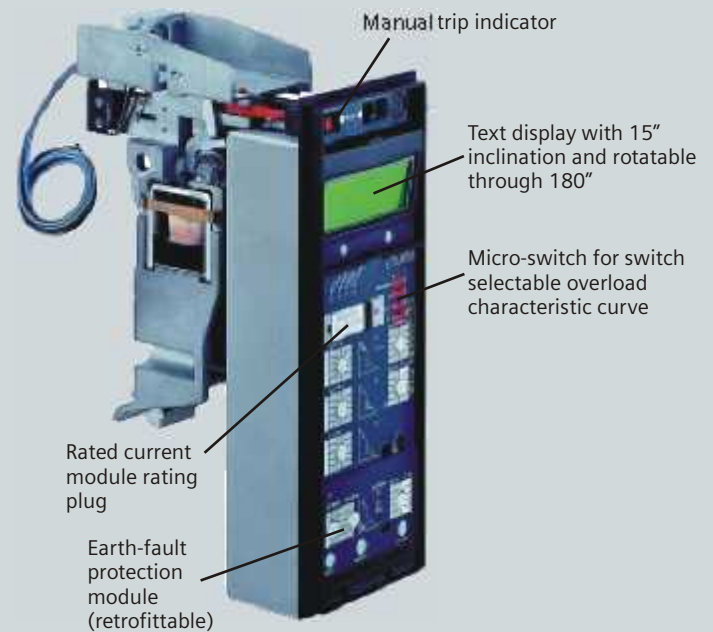

example : 1000A - 3WL -> up to 1000A  
 rating Plug 250A ; I<sub>r</sub> setting = 0.4 X 250 = 100A

### Application:

Cost-effective intelligent allrounder for building and all types of industrial applications- "Cubicle BUS integrated".

### Properties:

1. Adjustable time-lag class for overload protection
2. Short-time delayed short-circuit protection, adjustable from 1.25... 12 x I<sub>n</sub>
3. Instantaneous short-circuit protection adjusting 12 I<sub>n</sub>/Max/Off
4. Replaceable Rating Plug allows instant adaptability to required plant currents, thus ensuring overload protection of 100 A to 6300 A.
5. Switch-selectable characteristic of the overload and short-time delay short-circuit range (current discriminate) for finer selectivity conditioning to downstream fuses or protective devices
6. Thermal memory as restart protection in case of tripped motor circuits
7. Connectable and adjustable neutral conductor protection
8. Modular earth-fault protection, with separately adjustable alarm and trip function
9. Communication interface, metering function (Plus), connection of external modules as option or retrofit option.
10. Optional high-contrast display with viewing angle adjustment
11. Overload indicator
12. Display of cause of trip through LED
13. Option for testing the release
14. Setting of protective functions by means of rotary or slide switch.

## Overcurrent release ETU 76B

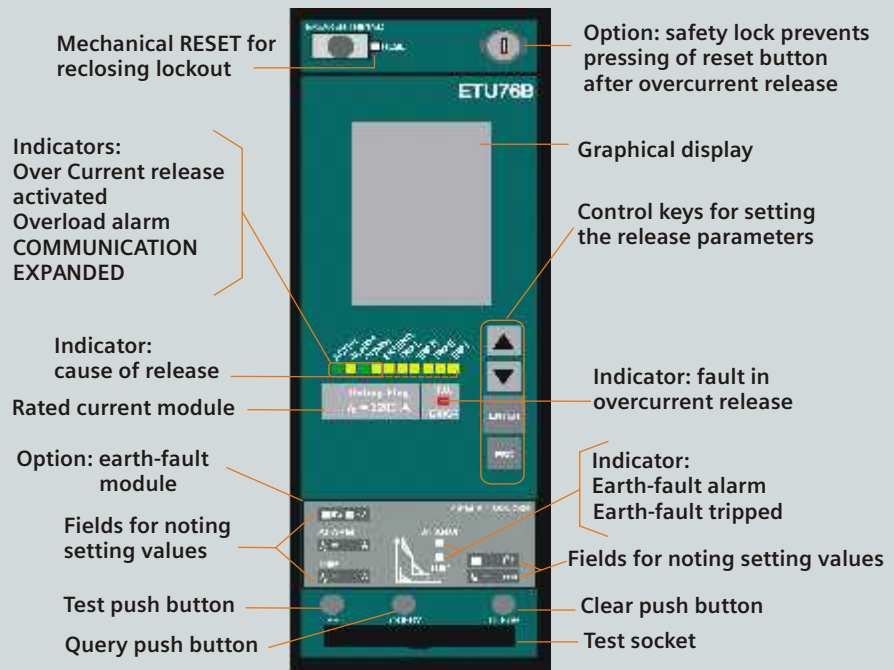

## Selection of the overcurrent releases

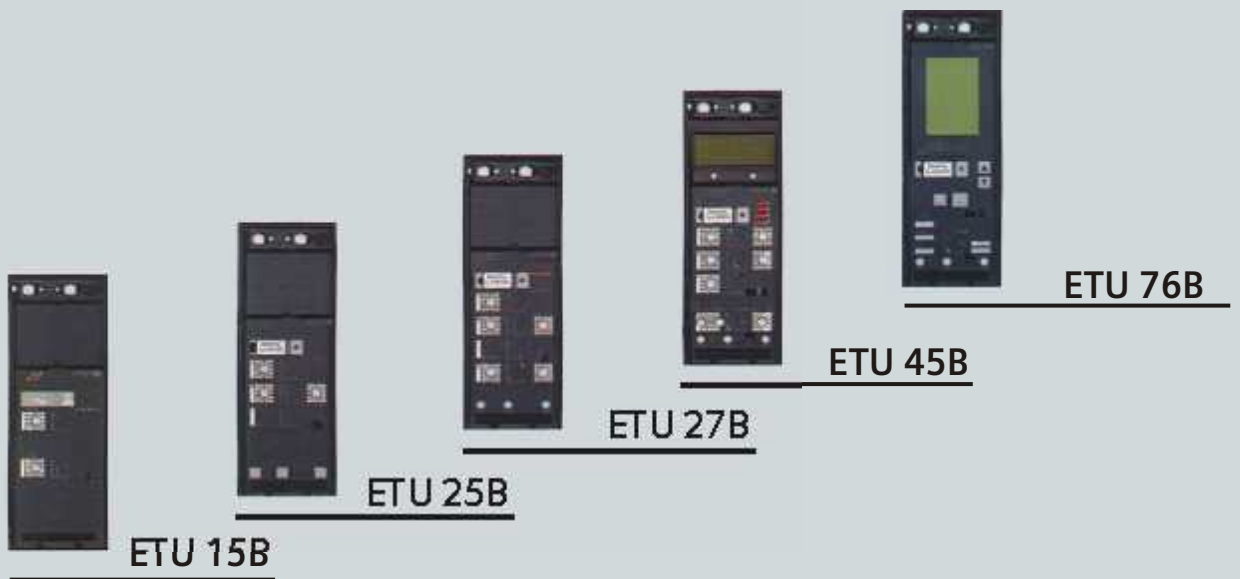

**Application:**

The multitalent with graphical display for network analysis "CubicleBUS integrated".

**Properties:**

As for ETU45B plus the following:

1. Two protective parameter steps that can be stored separately in the release (switch-selectable through external signal).
2. Overload protection that can be switched off for use with modern operating mechanism.
3. Adjustable lag of the delayed short-circuit protection up to 4000ms.
4. Neutral conductor protection adjustable to  $I_n = 2 I_n$ .
5. Setting of protective functions by means of control keys or Breaker Data Adapter or through communication interface.
6. Graphical display of all parameters and event/curve characteristics.
7. Storage of events and causes of release for specific error analysis.
8. High-contrast background - lit graphical display with sleep mode.



Ranges / Functions	Overload protection	Short-time delayed short-circuit protection	Instantaneous short-circuit protection	Protection of neutral conductor	Earth-fault protection	ZSI (zone-selective interlocking)	LCD 4 lines	LCD graphic	Communication via Profibus DP/MODBUS	Metering functions	Selectable parameter sets	Freely programmable parameters
ETU 15B	✓	—	✓	—	—	—	—	—	—	—	—	—
ETU 25B	✓	✓	✓	—	—	—	—	—	—	—	—	—
ETU 27B	✓	✓	✓	✓	✓	—	—	—	—	—	—	—
ETU 45B	✓	✓	✓	✓	○	○	○	—	○	○	—	—
ETU 76B	✓	✓	✓	✓	○	○	—	✓	○	○	✓	✓

✓ Available      — not available      ○ optional

## Tripping characteristics

Every release type and every setting has its own characteristic. You will find just a small selection of these illustrated below. The characteristics show the respective greatest and smallest setting range of SENTRON WL circuit-breakers with 1000A rated current, 690V rated voltage with various releases.

The characteristics show the behavior of the overcurrent release when it is activated by a current already flowing before the release. If the overcurrent release is not activated, the

opening time is prolonged up to 15ms, depending on the value of the overcurrent. To determine the total break-times of the circuit-breakers about 15ms must be added to the displayed opening times for the arc duration.

The displayed characteristics apply for ambient temperature at the circuit-breaker of -5 to +55 Deg C. The release can be operated at ambient temperatures of -20 to +70 Deg C.

SENTRON WL circuit-breakers with I = 1000 A and ETU 45B or ETU 55B electronic release  
Inverse-time delayed overload range L

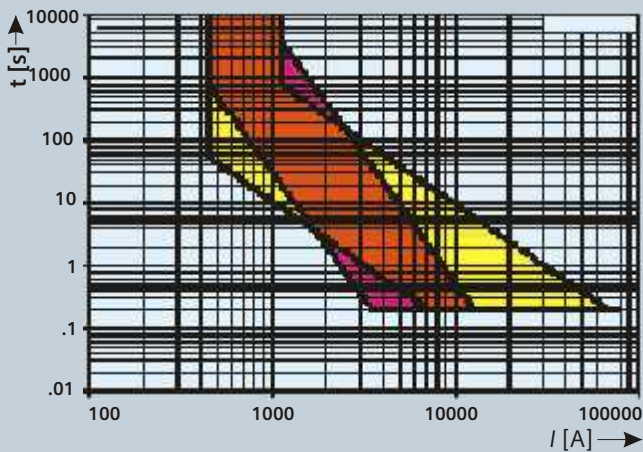

SENTRON WL circuit-breakers with I = 1000 A and ETU 45B or ETU 55B electronic release  
Instantaneous short-circuit range I

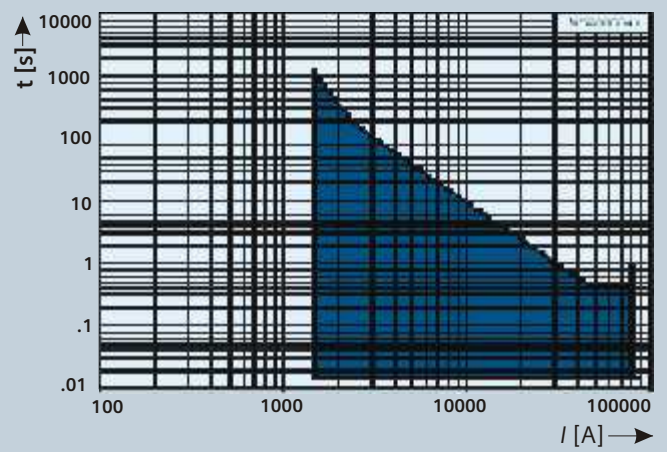

SENTRON WL circuit-breakers with I = 1000 A and ETU 45B or ETU 55B electronic release  
Earth-fault protection range G

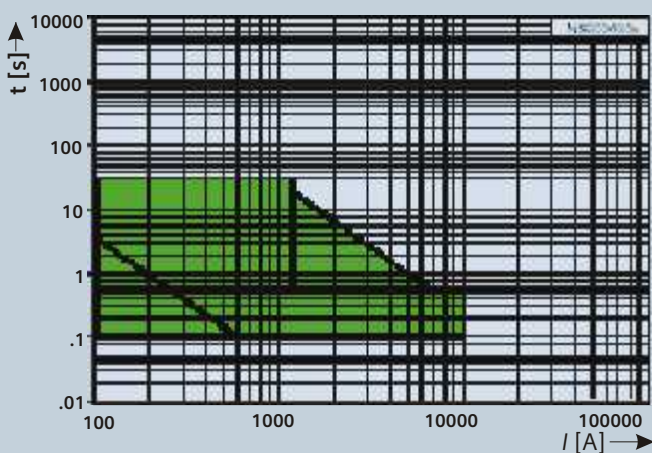

SENTRON WL circuit-breakers with I = 1000 A and ETU 45B or ETU 55B electronic release  
Short-time delayed short-circuit range S I

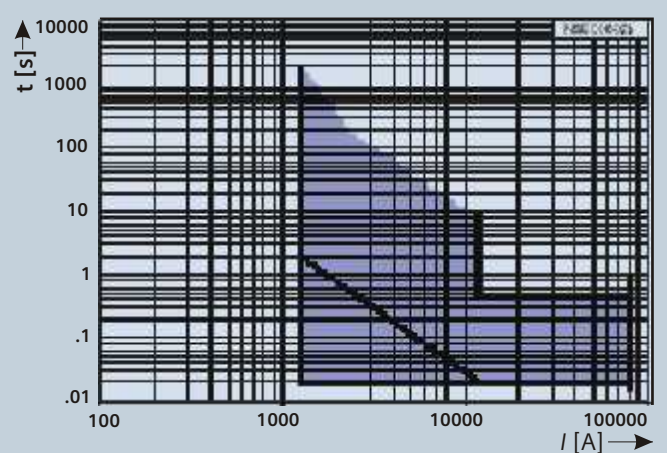

- Inverse-time delayed overload range  $L I^2 t = \text{constant}$
- Overlapping of the Inverse-time delayed overload range  $L I^2 t$  and  $I^4 t$
- Inverse-time delayed overload range  $L I^4 = \text{constant}$
- Instantaneous short-circuit range I
- Earth-fault protection range G
- Short-time delayed short-circuit range S

You will find further characteristics in the manual or in the SIMARIS deSign planning and configuring tool Or if you have any further queries, please contact your partner.



## Cost Saving

Simple, rapid retrofitting  
Reduced parts variance  
No derating till 55° C  
High power rating - low  
space requirement

## Easy to Plan

Perfectly Modular  
Circuit-breakers from  
100A to 6300A  
Simple planning with  
SIMARIS design

## System Solutions

State-of-the-art  
communication  
Diagnosis also possible  
via the Internet  
Power Management

# Technical Overview : SENTRON

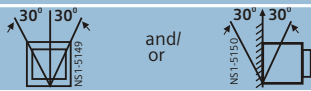
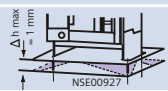
Size Type		up to 3WL11 10	I 3WL 11 12	3WL 11 16	3WL 12 08	II 3WL 12 10	3WL 12 12	3WL 12 16
<b>Rated current <math>I_n</math> at 55°C, at 50/60 Hz</b>								
Main conductor	A	up to 1000	1250	1600	800	1000	1250	1600
N-conductor (only with 4 poles)	A	up to 1000	1250	1600	800	1000	1250	1600
<b>Rated operational voltage <math>U_e</math> at 50/60 Hz</b>	AC V	up to 690	up to 690	up to 690	up to 690/ 1000	up to 690/ 1000	up to 690/ 1000	up to 690/ 1000
<b>Rated insulation voltage <math>U_i</math></b>	AC V	1000	1000	1000	1000	1000	1000	1000
<b>Rated impulse withstand voltage <math>U_{imp}</math></b>								
Main conducting paths	kV	12	12	12	12	12	12	12
Auxiliary circuits	kV	4	4	4	4	4	4	4
Control circuits	kV	2.5	2.5	2.5	2.5	2.5	2.5	2.5
<b>Isolating function according to DIN EN 60 947-2</b>		yes	yes	yes	yes	yes	yes	yes
<b>Utilization category</b>			B			B		
<b>Permissible ambient temperature</b>								
Operation	°C	-25/+70	-25/+70	-25/+70	-25/+70	-25/+70	-25/+70	-25/+70
Storage	°C	-40/+70	-40/+70	-40/+70	-40/+70	-40/+70	-40/+70	-40/+70
<b>Permissible load</b>								
up to 55°C	A	1000	1250	1600	800	1000	1250	1600
for rear horizontal	A	1000	1250	1600	800	1000	1250	1600
main contacts	A	1000	1210	1490	800	1000	1250	1600
<b>Rated short circuit making capacity <math>I_{cm}</math> (peak) kA</b>	Rating Class <sup>2)</sup>	N	/	S	S	/	H	
upto 500V		121	/	145	176	/	220	
upto 690V		88	/	105	165	/	187	
upto 1000V/1150V <sup>3)</sup>		-	/	-	-	/	105	
<b>Rated service short circuit breaking capacity, <math>I_{cs}</math> (r.m.s) kA</b>	Rating Class <sup>2)</sup>	N	/	S	S	/	H	
( $I_{cs} = I_{cu}$ )								
upto 500V		55	/	66	80	/	100	
upto 690V		42	/	50	75	/	85	
upto 1000V/1150V <sup>3)</sup>		-	/	-	-	/	50	
<b>Rated short time withstand current, <math>I_{cw}</math> kA</b>	Rating Class <sup>2)</sup>	N	/	S	S	/	H	
For 1 Sec at 50/60 Hz	1 Sec Rating	50 <sup>4)</sup>	/	50	66	/	80	
<b>Power loss at <math>I_n</math></b>								
with 3-phase symmetrical load								
Fixed-mounted circuit-breaker	W	100	105	150	40	45	80	85
Withdrawable circuit-breaker	W	195	205	350	85	95	165	175
<b>Operating times</b>								
Make-time	ms	35	35	35	35	35	35	35
Break-time	ms	38	38	38	34	34	34	34
<b>Endurance</b>								
Mechanical (without maintenance)	operating cycles	10 000	10 000	10 000	10 000	10 000	10 000	10 000
Mechanical (with maintenance)	operating cycles	20 000	20 000	20 000	15 000	15 000	15 000	15 000
Electrical (without maintenance)	operating cycles	10 000	10 000	10 000	75 00	75 00	75 00	75 00
Electrical (with maintenance)	operating cycles	20 000	20 000	20 000	15 000	15 000	15 000	15 000
<b>Switching frequency</b>								
690 V version	1/h	60	60	60	60	60	60	60
1000V/1150V <sup>3)</sup> version	1/h	-	-	-	20	20	20	20
<b>Minimum interval</b>	ms	80	80	80	80	80	80	80
Between release by overcurrent release and next closing of the circuit-breaker (only with autom mechanical reset of the reclosing lockout)								
<b>Mounting position</b>								
<b>Degree of protection</b>		upto IP 55			upto IP 55			
<b>Weights</b>								
<b>3-pole</b>	Fixed-mounted circuit-breaker	kg	43	43	43	56	56	56
	Withdrawable circuit-breaker	kg	45	45	45	60	60	60
	Guide frame	kg	25	25	25	31	31	31
<b>4-pole</b>	Fixed-mounted circuit-breaker	kg	50	50	50	67	67	67
	Withdrawable circuit-breaker	kg	54	54	54	72	72	72
	Guide frame	kg	30	30	30	37	37	37

**SENTRON WL:** An air circuitbreaker family for the complete spectrum of power distribution whether in building infrastructure or industrial applications.

# WL Air Circuit Breakers

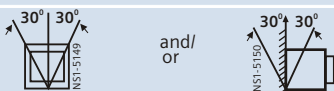
Size Type	II				III			
	3WL 12 20	3WL 12 25	3WL 12 32	3WL 1240	3WL 13 40	3WL 13 50	3WL 13 63	
<b>Rated current <math>I_n</math> at 55°C, at 50/60 Hz</b>								
Main conductor	A	2000	2500	3200	4000 <sup>3)</sup>	4000	5000	6300 <sup>1)</sup>
N-conductor (only with 4 poles)	A	2000	2500	3200	4000 <sup>3)</sup>	4000	5000	6300
<b>Rated operational voltage <math>U_e</math> at 50/60 Hz</b>	AC V	up to 690/ 1000	up to 690/ 1000	up to 690/ 1000	up to 690/ 1000	up to 690/ 1000	up to 690/ 1000	up to 690/ 1000
<b>Rated insulation voltage <math>U_i</math></b>	AC V	1000	1000	1000	1000	1000	1000	1000
<b>Rated impulse withstand voltage <math>U_{imp}</math></b>								
Main conducting paths	kV	12	12	12	12	12	12	12
Auxiliary circuits	kV	4	4	4	4	4	4	4
Control circuits	kV	2.5	2.5	2.5	2.5	2.5	2.5	2.5
<b>Isolating function according to DIN EN 60 947-2</b>		yes	yes	yes	yes	yes	yes	yes
<b>Utilization category</b>		B				B		
<b>Permissible ambient temperature</b>								
Operation	°C	-25/+70	-25/+70	-25/+70	-25/+70	-25/+70	-25/+70	-25/+70
Storage	°C	-40/+70	-40/+70	-40/+70	-40/+70	-40/+70	-40/+70	-40/+70
<b>Permissible load</b>								
up to 55° C	A	2000	2500	3200	3950	4000	5000	5920
for rear horizontal up to 60° C	A	2000	2500	3070	3810	4000	5000	5810
main contacts up to 70° C	A	2000	2280	2870	3600	4000	5000	5500
<b>Rated short circuit making capacity <math>I_{cm}</math> (peak) kA Rating Class<sup>2)</sup></b>								
upto 500V	N	/	S	/	H	H C		
upto 690V	145	/	176	/	220	220 / 330(3P), 286(4P)		
upto 1000V/1150V <sup>3)</sup>	105	/	165	/	187	187 / 330(3P), 286(4P)		
	-	/	-	/	105	105 / 154		
<b>Rated service short circuit breaking capacity, <math>I_{cs}</math> (r.m.s) kA (I<sub>cs</sub> = I<sub>cu</sub>)</b>								
upto 500V	N	/	S	/	H	H / C		
upto 690V	66	/	80	/	100	100 / 150(3P), 130(4P)		
upto 1000V/1150V <sup>3)</sup>	50	/	75	/	85	85 / 150(3P), 130(4P)		
	-	/	-	/	50	50 / 70		
<b>Rated short time withstand current, I<sub>cw</sub>. KA For 1 Sec at 50/60 Hz</b>	Rating Class <sup>2)</sup> 1 Sec Rating	N	/	S	/	H	H / C	
		55	/	66	/	80	100	100
<b>Power loss at I<sub>n</sub></b>								
with 3-phase symmetrical load								
Fixed-mounted circuit-breaker	W	180	270	410	750	520	630	900
Withdrawable circuit-breaker	W	320	520	710	925	810	1050	1600
<b>Operating times</b>								
Make-time	ms	35	35	35	35	35	35	35
Break-time	ms	34	34	34	34	34	34	34
<b>Endurance</b>								
Mechanical (without maintenance)	operating cycles	10 000	10 000	10 000	10 000	5000	5000	5000
Mechanical (with maintenance)	operating cycles	15 000	15 000	15 000	15 000	10 000	10 000	10 000
Electrical (without maintenance)	operating cycles	75 00	7500	4000	4000	2000	2000	2000
Electrical (with maintenance)	operating cycles	15 000	15 000	15 000	15 000	10 000	10 000	10 000
<b>Switching frequency</b>								
690 V version	1/h	60	60	60	60	60	60	60
1000V/1150V <sup>3)</sup> version	1/h	20	20	20	20	20	20	20
<b>Minimum interval</b>	ms	80	80	80	80	80	80	80
Between release by overcurrent release and next closing of the circuit-breaker (only with autom mechanical reset of the reclosing lockout)								
<b>Mounting position</b>								
<b>Degree of protection</b>		upto IP 55				upto IP 55		
<b>Weights</b>								
<b>3-pole</b>	Fixed-mounted circuit-breaker	kg	56	59	64	85	82	90
	Withdrawable circuit-breaker	kg	60	63	68	121	88	96
	Guide frame	kg	31	39	45	52	60	70
<b>4-pole</b>	Fixed-mounted circuit-breaker	kg	67	71	77	103	99	108
	Withdrawable circuit-breaker	kg	72	76	82	146	106	108
	Guide frame	kg	37	47	54	62	84	119

\* 1) At 40°C \* 2) N-Normal; S-Standard; H-High 3) Class "C" - Very high breaking capacity 4) for 0.5 sec

# Customised solutions: SENTRON WL

- ① Draw-Out-Frame
- ② Main Terminals Front, Flange, Horizontal, Vertical
- ③ Position-Indicating Switches
- ④ Leading Earth Contact
- ⑤ Shutters
- ⑥ COM 15 PROFIBUS/MODBUS COM 16 module
- ⑦ External CubicleBUS Module
- ⑧ Closing Coil, Auxiliary Releases
- ⑨ Auxiliary Plug-in System
- ⑩ Auxiliary Contact Block
- ⑪ Door Sealing Frame
- ⑫ Interlocking Kit
- ⑬ Transparent Cover, Function Block
- ⑭ Emergency Stop Pushbutton, Key Operator
- ⑮ Motorized Operator
- ⑯ Switch Operation Counter
- ⑰ Breaker Status Sensor (BSS)
- ⑱ Electronic Trip Unit (ETU)
- ⑲ Reset Coil
- ⑳ Breaker Data Adapter (BDA)
- ㉑ Four line LCD Module
- ㉒ Earth-Fault Protection Module
- ㉓ Rating Plug Module
- ㉔ Metering Module
- ㉕ Sentron WL Circuit-Breaker



# with optional accessories

**SETRON WL:** superior individual products, integrated into comprehensive power distribution system-to the extent of providing solutions specific to particular industrial sector and infrastructure projects



## 3 and 4 pole, up to 6300A- fixed mounted and withdrawable version

### Description

#### CIRCUIT-BREAKERS

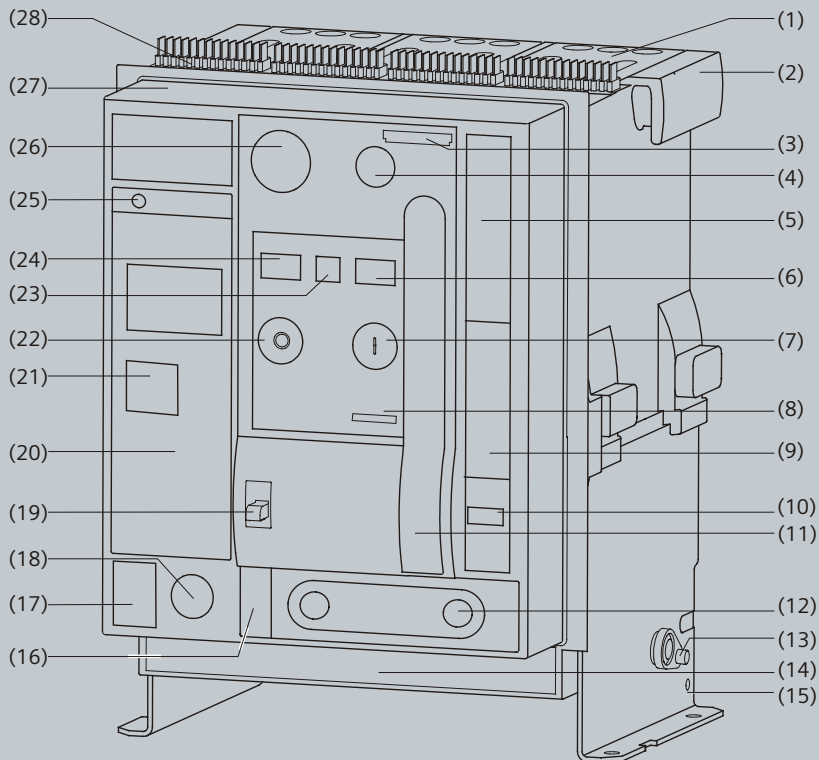

- 1) Arc chute
- 2) Handle
- 3) ID label
- 4) Motor switch (optional) or "electrical ON" (optional)
- 5) Type label of circuit-breaker
- 6) Spring charge indicator
- 7) "Mechanical ON" button
- 8) Rated current data
- 9) Insertion pogrammm
- 10) Operating cycle counter (optional)
- 11) Charging lever
- 12) Crank handle
- 13) Transport shalt for withdrawable unit
- 14) Equipment label
- 15) Earth terminal
- 16) Position indicator
- 17) Earth fault protection table
- 18) Crank handle safety lock
- 19) "Mechanical OFF" button or "emergency OFF" mushroom push button (optional)
- 20) Ready-to-close indicator
- 21) Contact position indicator
- 22) Trip indicator (reset button)
- 23) Locking device "Safe OFF" (optional)
- 24) Front panel
- 25) Terminal strip for auxiliary contacts

### Description

#### GUIDE FRAME

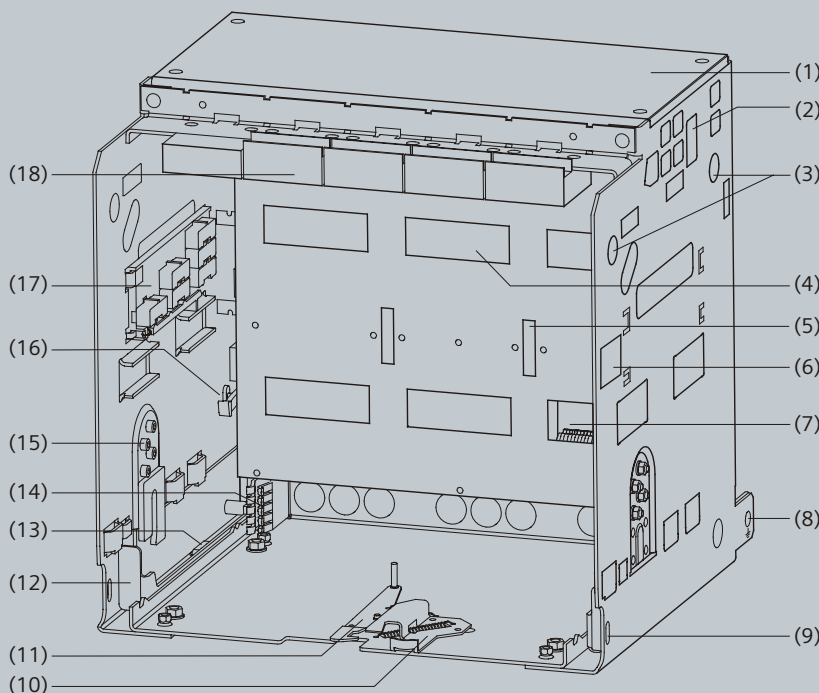

- 1) Arc chute cover (optional)
- 2) Arcing openings
- 3) Opening for crane hooks
- 4) Shutter (optional)
- 5) Locking device (shutter) (optional)
- 6) Type label for guide frame
- 7) Disconnecting contact
- 8) Earthing terminal O14 mm
- 9) Locking device travel rail
- 10) Locking device against moving if the cubicle door is open (optional)
- 11) Door interlock for guide frame (optional)
- 12) Guide rail
- 13) Ampere rating coding by factory
- 14) Sliding contact for circuit-breaker earthing (optional)
- 15) Option related coding
- 16) Shutter operating device (optional)
- 17) Position signal switch (optonal)
- 18) Sliding contact module for auxiliary conductor (quantity is equipment-dependent)

## Description

### Auxiliary release

Up to two auxiliary releases can be installed at the same time. The following are available:  
1 shunt release or 1 undervoltage release or 2 shunt releases or 1 shunt release + 1 undervoltage release.

#### Shunt release

The shunt release instantly turns off the circuit-breaker when the working voltage is applied. The shunt release "F1" is available in two versions; 5% duty ratio for over excitation and 100% duty ratio for permanent-magnet excitation. This can be used as lock-out against startup.

An energy storage device for the shunt release allows the circuit breaker to be turned off after a control voltage failure.

#### Undervoltage release

The undervoltage release turns off the circuit breaker when the working voltage falls below a specific value or is not applied. The circuit breaker cannot be switched ON manually or by means of an electrical ON command if the undervoltage release is not given the rated voltage. The under voltage release "Y1" is without time lag as standard and the customer can switch between  $t_1 < 80\text{ms}$  and  $t_1 < 200\text{ms}$ .

A further version is available : undervoltage release with 0.2 to 3.2 s lag.

#### Signal contact for auxiliary release

One signal contact per auxiliary release is available to interrogate the switching positions of the auxiliary release.

#### Closing solenoid

Serves to electrically close the circuit breaker by means of a local or remote electrical "ON" button.

##### *Motorized operating mechanism*

For automatic charging of the stored energy mechanism. Is switched on when the stored energy mechanism is released and the control voltage is available. Automatically switch off after charging. Manual actuation of the storage can function independently. *Display message and control elements.*

#### Interlocking set

The interlocking set is required when the operability of the mechanical ON and OFF buttons need to be adapted to special demands of the switchgear operation by retrofitting various accessories (e.g. Safety locks, access lock-outs preventing tool operation, seals.)

#### Motor switch

Knob-operated switch for turning off the motorized operating mechanism.

#### Operating cycle counter

A 5-digit operating cycle counter is available with the motorized operating mechanism. The display is incremented by "1" as soon as the stored energy mechanism is fully charged.

#### Resetting the manual trip signal

If the circuit breaker has been tripped, this is indicated by the protruding red reset button on the ETU.

Actuation of the reset button resets the trip solenoid and the trip signal. If this manual indicator is to be remotely reset, the option is available to equip the reset button with a reset solenoid. With this option, the circuit breaker can be reset both manually and electrically.

#### Automatic reset of the reclosing lockout

If the ETU is released the circuit breaker cannot be reclosed until the release has been either electrically or manually reset with the option "automatic reset of the reclosing lockout", the circuit breaker is ready-to-close immediately after a release. The reset of the manual trip indicator is not contained in this option.

#### Trip signal switch

If the circuit breaker is tripped through overload, short-circuit or earth fault, this can be indicated by the trip signal switch. This signal switch is available as an optional extra. If the circuit breaker is communication capable, this option is available as standard.

#### Ready-to-close signal contact

The SENTRON WL circuit breakers are equipped with a visual ready-to-close facility as standard. The option to transmit this readiness to close over a signal contact is also available. If the circuit breaker is operated through communication, this signal switch is fitted as standard.

## Locking Device

### Locking device in OFF position

This function prevents the circuit breaker being closed and fulfils the main switch-characteristics according to EN 60 204 (VDE 0113)- line disconnecter. This locking only affects this circuit breaker.

After a circuit breaker is replaced, it is no longer possible to prevent it being closed unless the new circuit breaker is also protected against unauthorized closing.

To activate the locking device, the circuit breaker must be open. If the circuit breaker is closed, the locking device is blocked. The blocking is only effective if the key is withdrawn. The safety key can only be withdrawn in the "OFF" position.

### Locking device for "electrical ON"

Prevents unauthorized electrical closing at the front panel. Mechanical and remote closing are still possible. The blocking is only effective if the key is withdrawn.

### Locking device for "mechanical ON"

Prevents unauthorized mechanical closing. The mechanical ON button can only be actuated if the key is inserted (key operation). Closing through the "electrical ON" or remote closing are still possible. The blocking is only effective if the key is withdrawn.

### "Safe OFF" switch independent locking device against unauthorized closing.

This special function for withdrawable circuit breakers prevents closing, independent of circuit breaker, and fulfils the main switch-characteristics according to EN 60 204 (VDE 0113)- line disconnecter. Unauthorized closing is also not possible after replacement of a circuit breaker. To activate the locking, the circuit breaker must be switched off. If the circuit breaker is switched on, the locking device is blocked. The blocking is only effective if the key is withdrawn. The safety key can only be withdrawn in the "OFF" position.

### Locking device for crank handle

Prevents withdrawal of the crank handle. The circuit breaker is protected against moving. The blocking is only effective if the key is withdrawn.

### Locking device for mechanical "OFF"

Prevents unauthorized mechanical disconnection at the front panel. The mechanical "OFF" button can only be actuated if the key is inserted (key operation). Remote disconnection is still possible. The blocking is only effective if the key is withdrawn.

### Locking device for charging lever

The charging lever can be locked with a padlock making it impossible to manually charge the stored energy mechanism.

### Locking device against resetting the trip indicator

A lockable cover prevents the manual resetting of the trip indicator after an overcurrent release. This locking device is delivered together with the option transparent cover for overcurrent release.

## Sealing devices

### Sealing cap over "electrical ON" button

The "electrical ON button" is fitted with a sealing cap as standard.

### Sealing cap over "mechanical ON" and "OFF" button

The interlocking set includes blanking caps that can be sealed.

### Sealing device for overcurrent release

The transparent cover can be sealed. The areas of the parameter setting are covered against unauthorized access. Openings enable access to the query and test button.

### Closing lockout with open cubicle door

The readiness to close is mechanically deactivated if the cubicle door is open. The circuit breaker cannot be closed either mechanically or electrically. Transmission of the locking signal by means of the Bowden wire.

### Locking device against moving if the cubicle door is open for withdrawable circuit-breakers

The crank handle is blocked if the cubicle door is open and cannot be withdrawn. It is not possible to move withdrawable circuit breakers. The blocking is only effective if the crank handle is inserted.

### Rated current coding between circuit-breaker and guide frame

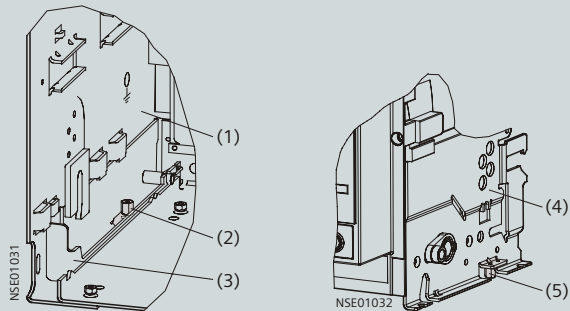

- (1) Guide frame, inside left; inside right are the same
- (2) Coding bolt on the guide rail in the guide frame
- (3) Guide rail
- (4) Withdrawable circuit-breaker right side; left side are the same
- (5) Coding bolt on guide frame



### Interlocking of cubicle door

The cubicle door cannot be opened if the

- fixed-mounted circuit breaker is closed (transmission of the locking signal by means of Bowden wire) or
- if the withdrawable circuit breaker is in connected position.

### Access locking through the "mechanical ON" and "OFF" button

The "mechanical ON" and "OFF" buttons are protected by a cover that only permits actuation with a tool. These caps are components of the interlocking set.

### Additional equipment for guide frames

#### Shutter

The cover strips of the shutter lock the laminated contacts of the guide frame if the withdrawable circuit breaker is withdrawn so that they fulfil the function of a touch guard.

The cover strips can be manually opened with the strip lifter.

The cover strips can be fixed in different positions with padlocks and protected from unauthorized manipulation.

### Rated current coding between circuit breaker and guide frame

Withdrawable circuit breakers and guide frames are equipped with a rated current coding as standard. This ensures that in a guide frame only those circuit breakers can be inserted whose contact strips match the laminated contacts of the guide frame. (see picture above)

### Option related coding

Withdrawable circuit breakers and guide frames can be retrofitted with an option related coding. This permits the unique assignment of circuit breakers and guide frames, taking into account different equipment. If circuit breakers and guide frames do not have the same coding. It is not possible to insert the circuit breaker.

Circuit breakers and guide frames, taking into account different equipment. If circuit breakers and guide frames do not have the same coding. It is not possible to insert the circuit breaker. There are 36 selectable coding options.

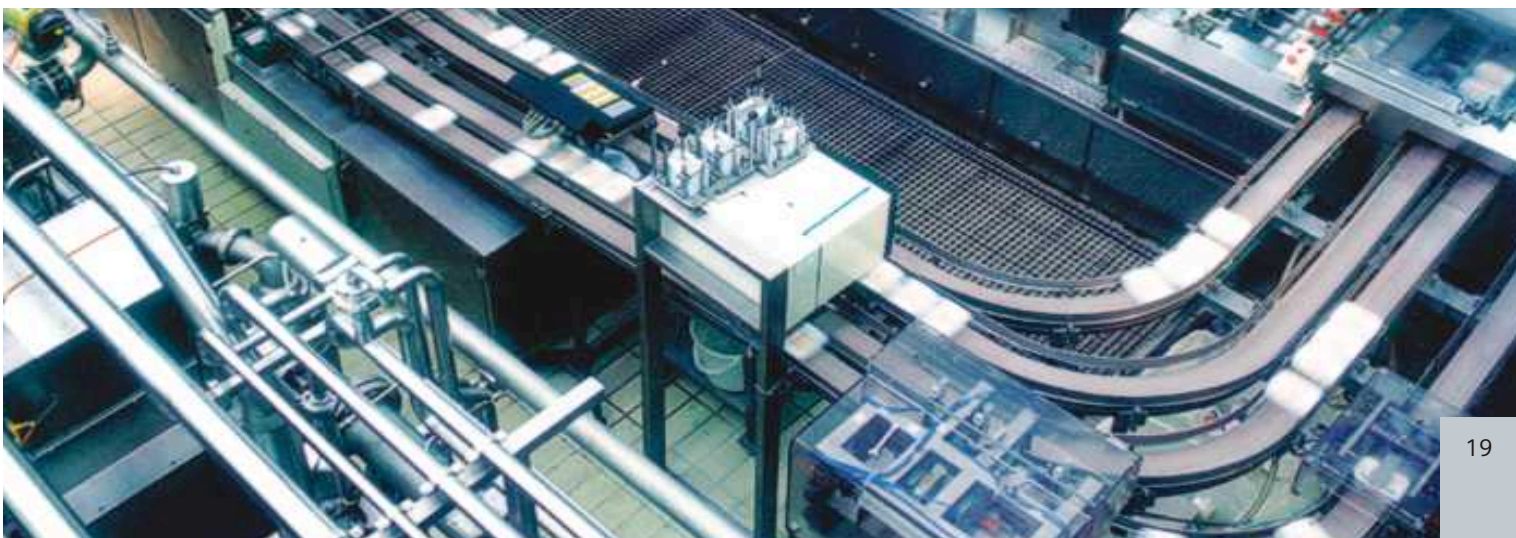

### Position signal contact for guide frame

Position signal contacts can be retrofitted to the guide frame. These can be used to analyze the position of the circuit breaker in the guide frame.

### Mutual mechanical circuit breaker interlocking

The module for mutual mechanical interlocking can be implemented for two or three SENTRON WL circuit breakers and is simple to adapt to the respective version. Fixed mounted and withdrawable circuit breakers are compatible and can be implemented together in a single system. This is also possible with circuit breakers 3WT.

The circuit breakers can be installed either next to one another or on top of one another, whereby the distance between the circuit breakers is determined only by the length of the Bowden wire.







The Bowden wire are available upto a length of 6m. Lockout signal are forwarded over the Bowden wires with withdrawable circuit breakers the interlocking is only effective in connected position. The mechanical service life of Bowden wires is 10000 operating cycles.

For the mutual mechanical interlocking of circuit breakers also see the adjacent table.

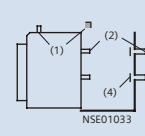
### Phase barriers

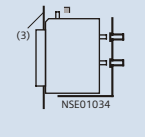
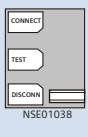
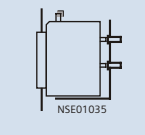
Plant manufacturers can make phase barriers out of insulation material as a protection against internal arcs. Guiding grooves are provided at the rear of the fixed-mounted circuit breaker or guide frame.

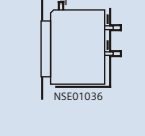
Position of the withdrawable circuit breaker in the guide frame

	Representation	Position indicator	Main circuit	Auxiliary circuit	Cubicle door	Shutter
<b>Maintenance position</b>			Disconnected	Disconnected	Open	Closed
<b>Disconnected position</b>			Disconnected	Disconnected	Closed	Closed
<b>Test position</b>			Disconnected	Connected	Closed	Closed
<b>Connected position</b>			Connected	Connected	Closed	Open

(1) Auxiliary circuit  
(2) Main circuit  
(3) Cubicle door  
(4) Shutter

Mutual mechanical interlocking of circuit breaker - examples

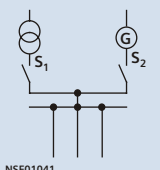
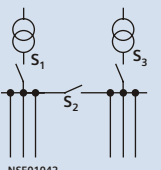
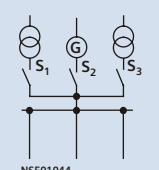
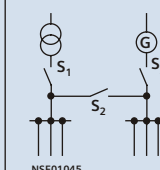
Interlocking of two mutual circuit breakers	Interlocking of three non-mutual circuit breakers	Interlocking of three mutual circuit breakers	Interlocking of three circuit breakers, two of which are mutual
			

### Arc chute cover

The arc chute cover is available as an optional features for the guide frame. It serves to protect switchgear parts that are located directly next to the circuit breaker.



integrated  
**CubicleBUS**

BREAKER TRIPPED

RESET

IL 1		227	R	A
IL 2		232	R	A
IL 3		237	R	A
IN		0	R	A

ACTIVE ALARM COMB. EXTENDED

ETU45B  
Release 2

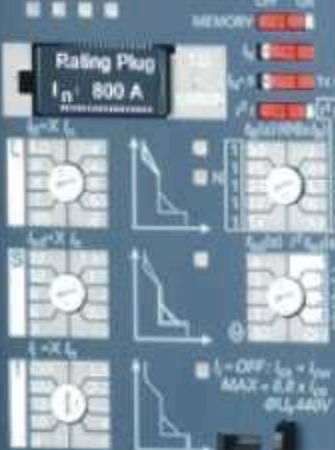

TEST QUERY CLEAR

KONTAKTE BEREIT SPEICHER

OPEN

OK

CHARGED

CONTACTS READY SPRING

AUS

EIN

OPEN

PUSH TO

CLOSE

SIEMENS

WL II 800 S

IEC / EN 6047-2  
CE  
N117  
A001566  
Cat. B  
 $I_{pmax}$  800 A  
 $U_i$  1000 V- 50 / 60 Hz  
 $U_{imp}$  12 kV  
 $U_n$  800V- 800V-  
 $I_{res} 10ms$  80 kA 75 kA  
 $I_{res} 0.5s$  80 kA 75 kA  
 $U_n$  1000 V-  
 $I_{res} 10ms$  -  
 $I_{res} 0.5s$  -  
980 V  
ID No. 0004012802246/05



TOTALLY  
INTEGRATED  
POWER BY  
Siemens

TOTALLY  
INTEGRATED  
AUTOMATION BY  
Siemens

3WL1208-3FB35-4GGZ  
Z=C22 F02

MADE IN GERMANY

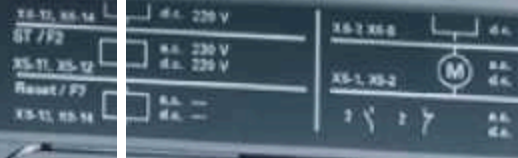

# Technological leaders amongst the Circuit breakers:

- 1 SENTRON 3VL Circuit Breaker
- 2 Microprocessor based release with LCD
- 3 Microprocessor based release
- 4 COM10 PROFIBUS /COM11 MODBUS module with. ZSI
- 5 COM20 PROFIBUS /COM21 MODBUS module with. ZSI
- 6 Breaker Data Adapter (BDA)
- 7 BDA *Plus* with Ethernet Interface
- 8 Browser-capable input & output (e.g notebook)
- 9 SENTRON 3WL Circuit Breaker
- 10 COM 15 PROFIBUS / COM 16 MODBUS Module
- 11 Breaker Status Sensor (BSS)
  - 1) For a MODBUS connection the COM16 module is required
  - 2) For a MODBUS connection the COM21 module is required
- 12 Microprocessor based release
- 13 Metering function *Plus*
- 14 ZSI (Zone-Selective Interlocking) module
- 15 Digital output module as relay contacts
- 16 Digital output module as relay contacts, configurable
- 17 Analog output module
- 18 Digital input module
- 19 Switch ES Power on PC
- 20 PLC e.g. SIMATIC S7
- 21 Power Management System
- 22 Communication capable SENTRON Power Monitoring Devices

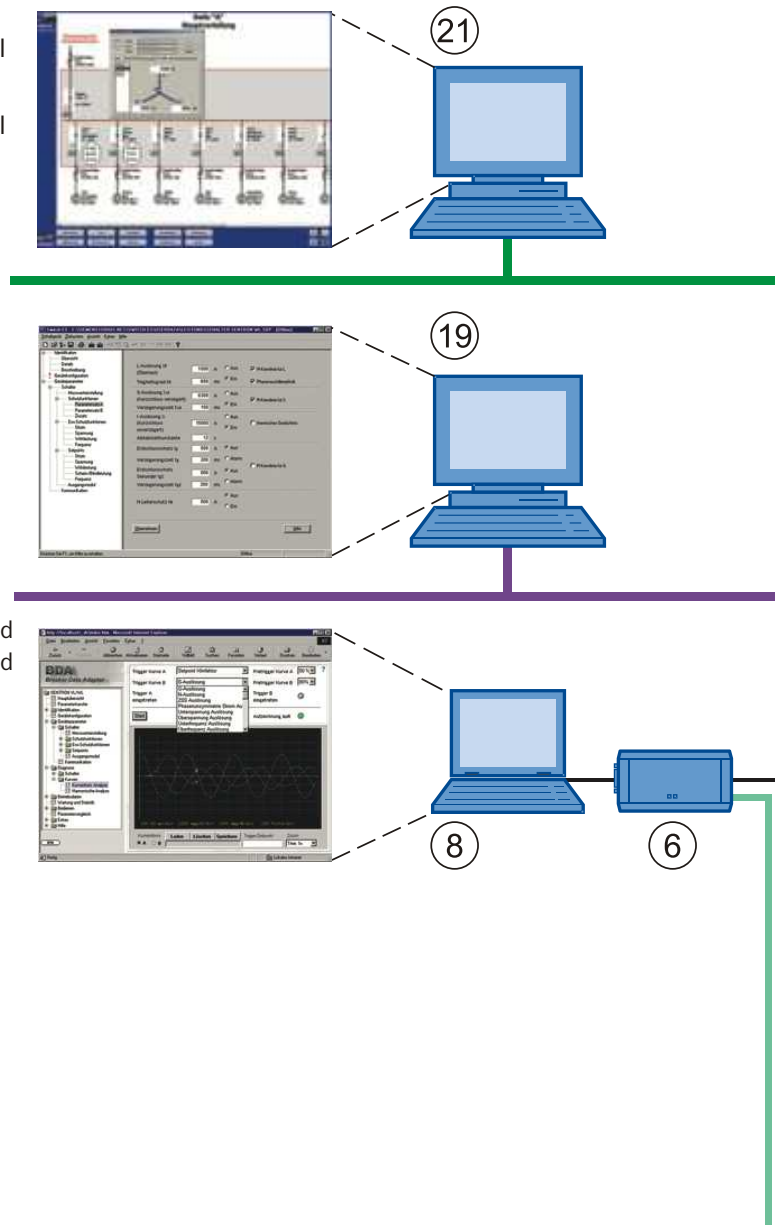

# SENTRON Communication Solution

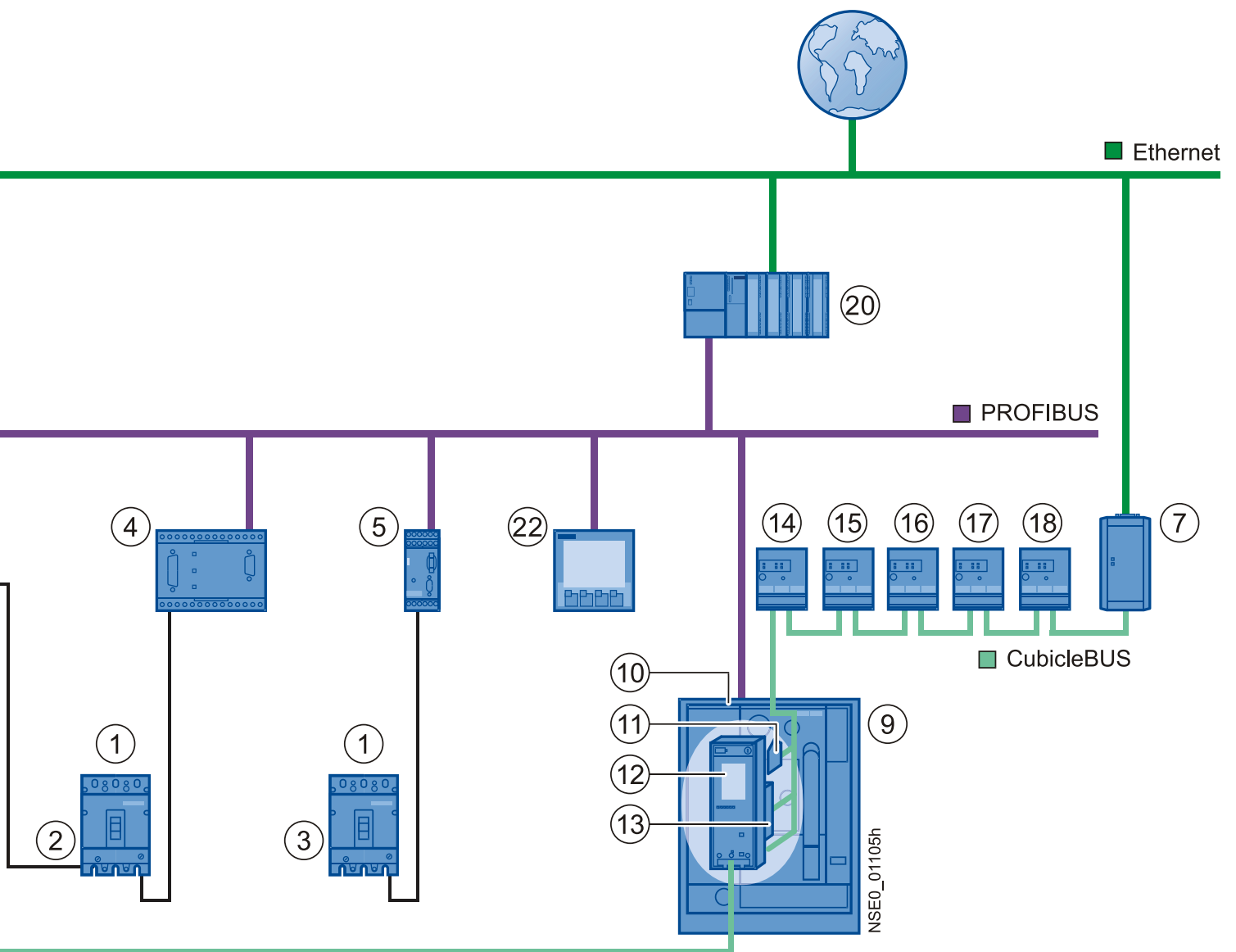



The Cubicle BUS is the internal bus system, providing the interconnection between all the intelligent components within the SENTRON WL (e.g. trip unit, Breaker Status Sensor, metering function, communication module). It also permits the simple connection of external accessory components (CubicleBUS Module, BDA Plus) to the circuit-breaker. It is integrated as standard on all SENTRON WL circuit breakers equipped with ETU45B and above.

### External CubicleBUS Module:

By means of CubicleBUS, external accessory modules can be connected to the SENTRON WL with minimum wiring. Available modules include: digital output modules, analog output modules, digital input modules as well as ZSI modules for zone-selective interlocking. By using these accessories, one can save the need for similar discrete peripheral modules.

#### Digital output module with rotary switch

6 binary signals on the breaker status (causes of trip and warning) can be output over this module to external signaling devices (e.g. Light, horn) or used to switch off of other specific plant parts (e.g. Frequency converter). Digital output modules are available with or without rotary switches.

With rotary switch modules, you can choose between two signal blocks each with 6 defined assignment and an additional response delay. All digital output modules are available either as an optocoupler output (NO contact, 150 mA) or a relay output version (change-over, up to 12A). Two modules of this type may be connected to a SENTRON WL.



#### Digital output module configurable

The configurable output module is available for more powerful solutions. In this case, many events on the CubicleBUS can be directly switched to one of the six available outputs, or three of the outputs can be assigned up to six events, i.e. Up to six events can be applied to a single physical output with an "OR" logic operation. The configuration is executed either with BDA/BDA Plus or Switch ES Power. As with the output modules with rotary switch, an optocoupler and a relay variant are available.

Only one module of this type can be implemented through SENTRON WL.



#### Analog output module

The analog output module can be used to output the following measured values of the circuit breaker to analog display devices on the cubicle door

- $I_{L1}, I_{L2}, I_{L3}, I_N$  or
- $\cos\phi_1, \cos\phi_2, \cos\phi_3, \Delta I\%$  or
- $U_{L12}, U_{L23}, U_{L31}, U_{LIN}$  or
- $f_{avg}, U_{LLavg}, P_{tot}, \cos\phi_{avg}$
- $P_{L1}, P_{L2}, P_{L3}, S_{tot}$  or

Four 4-20-mA/0-10V interfaces are available for this purpose. The measured values to be output are selected with a rotary switch. This analog output module means there is no need for additional transformers requiring conventional installation/wiring in the main bus. Two modules of this type may be connected to a SENTRON WL.



#### Digital input module

The digital input module supports connection of 6 additional binary signals (24V DC) within the circuit breaker environment to the system. This enables, for example, the status signaling of a switch disconnector or of a cubicle door to be transmitted to PROFIBUS-DP.

With the digital input module on the Cubicle BUS, it is also possible to automatically switch the two different protective parameter set held in the ETU 55B. And ETU- 76B releases. This allows, among other things, the automatic changing of the parameters of a tie switch in the event of a power supply failure.

One module each of this type can be implemented for the input of the six digital signals and for the automatic switchover of the parameters.



#### ZSI module

If Siemens circuit-breakers are arranged in several levels and minimal delays are desired, it is advisable to use the ZSI module.

The circuit breakers are interconnected by these modules. In the event of a short-circuit all circuit breakers communicate to determine and isolate the exact short-circuit location. This way only the next upstream circuit breaker line energy flow direction will be opened.



## COM15 / COM16

By means of the PROFIBUS module COM15 or MODBUS module COM16 the circuit breakers can be connected directly to the PROFIBUS-DP or Modbus network. The COM modules support the innovative DPV1 functions. This guarantee the simplest commissioning and diagnosis of the circuit-breaker as well as facilitates optimal visualization of the data.



## Metering Function PLUS:

The integrated metering function can be used with all trip units, equipped with CubicleBUS interface. It is an interesting alternative to external multifunction metering devices. Measured values include currents, voltages, powers, energy, cos  $\phi$  and frequency.

The data can be shown on the display of the overcurrent releases, transmitted to the PROFIBUS-DP through the COM15(or MODBUS through COM16) and transferred to the outputs external CubicleBUS modules.



Measured parameters	Range	Accuracy
Currents I L1, IL2, IL 3, IN, Ig	30 ..... 8000 A	$\pm 1\%$ of measurement range.
Line Voltages VL12,VL23,VL31	15 ..... 130V and 130 .... 1150 V	$\pm 1\%$ of measurement range.
Phase Volatage VL1N, VL2N, VL3N	10....75V and 75....700 V	$\pm 1\%$ of measurement range.
Present average of line voltages V avg	10....75V and 75 ...700 V	$\pm 1\%$ of measurement range.
Apparent Power SL1,SL2,SL3	13....8000 kVA	$\pm 2\%$ of measurement range.
Total apparent power	13.....24000kVA	$\pm 2\%$ of measurement range.
Active power PL1, PL2,PL3	-8000 ....+ 8000 kW	$\pm 2\%$ of apparent power ( $\cos\phi > 0.6$ )
Total active power	-24000 .... + 24000 kW	$\pm 2\%$ of apparent power ( $\cos\phi > 0.6$ )
Total reactive power	-20000 .... + 20000 kVar	$\pm 4\%$ of apparent power
Reactive power QL1, QL2,QL3	-6400 ..... +6400 kVar	$\pm 2\%$ of apparent power .
Power factor Cos $\phi$ 1, Cos $\phi$ 2, Cos $\phi$ 3	-0.6 .... 1 .... +0.6	$\pm 4\%$
Power factor total	-0.6 .... 1 .... +0.6	$\pm 4\%$
Long term average of currents II1, II2, II3	30 ..... 8000 A	$\pm 1\%$ of measurement range.
Long term average of 3-phase current	30 ..... 8000 A	$\pm 1\%$ of measurement range.
Long term average of active power in L1, L2, L3.	13 ..... 8000 kW	$\pm 2\%$ of apparent power ( $\cos\phi > 0.6$ )
Long term average of active power 3 phase.	13 ..... 8000 kW	$\pm 2\%$ of measurement range.
Long term average of apparent power in L1, L2, L3 and Total apparent power	13 ..... 8000 kVA	$\pm 2\%$ of measurement range.
Long term average of reactive power 3 phase.	- 8000 ..... + 8000 kVar	$\pm 2\%$ of apparent power .
Energy consumed	1 ..... 10000 MWh	$\pm 2\%$
Energy delivered	1 ..... 10000 MWh	$\pm 2\%$
Reactive energy consumed	1..... 10000 MVarh	$\pm 2\%$
Reactive energy delivered	1..... 10000 Mvarh	$\pm 2\%$
Frequency	15 .....40 Hz 40 ---- 70 Hz 70 ---- 440 Hz	$\pm 0.1$ Hz
Distortion factor of current and voltage	2 .... 100%	$\pm 2\%$ of measurement range upto 29th harmonic
Phase unbalance of current and voltage	2 ..... 150%	$\pm 1\%$ of displayed value.

**Extended Protective functions:**

The Metering Function PLUS is used to implement extended protective functions beyond the functionality of the overcurrent releases. If one of these parameters exceeds or falls below its default settings, the overcurrent release is tripped if the set event persists longer than the delay time.

Parameters	Range	Delay
Under voltage pickup	100 .... 1100 V	1.... 15 s
Over voltage pickup	200 ... 1200 V	1.....15 s
Active power in normal direction	13 .... 4000 kW	2 ....15 s
Active power in reverse direction	13 .... 4000 kW	2 ....15 s
Overfrequency pickup	40 ... 70 Hz	1....15 s
Under frequency pickup	40 ....70 Hz	1....15 s
Phase current unbalnce pickup	5.... 50%	1....15 s
Phase voltage unbalnce pickup	5....50%	1....15 s
Phase rotation		
Pickup THD current	5 .....50%	5 ....15 s
Pickup THD volatge	5 .....50%	5 ....15 s

**Setpoints:**

The metering function PLUS provides Setpoint Function for automatic monitoring of operating conditions and generating warnings on violation to set threshold values. These can be communicated on the CubicleBUS and transferred via COM15. Please Note: violation of setpoint values never sends tripping signal to ETU.

Parameters	Range	Delay
Phase overcurrent	30 ..... 10000 A	1 ..... 255 s
grond overcurrent	30 ..... 10000 A	1 ..... 255 s
neutral overcurrent	30 ..... 10000 A	1 ..... 255 s
phase current unbalance	5 .....50%	1 ..... 255 s
current demand	30 .....10000 A	1 ..... 255 s
under voltage	15 ..... 1200 V	1 ..... 255 s
phase voltage unbalance	5 ... 50%	1 ..... 255 s
over voltage	15 ..... 1200 V	1 ..... 255 s
over power in normal direction	13 ..... 10000 kW	1 ..... 255 s
kW reverse	13 ..... 10000 kW	1 ..... 255 s
kW demand	13 ..... 10000 kW	1 ..... 255 s
kVA demand	13 ..... 10000 kVA	1 ..... 255 s
KVAR demand	13 ..... 10000 kVar	1 ..... 255 s
KVAR consumed	13 ..... 10000 kVAR	1 ..... 255 s
KVA	13 ..... 10000 kVA	1 ..... 255 s
over frequency	40 .... 70 Hz	1 ..... 255 s
under frequency	40 .... 70 Hz	1 ..... 255 s
under power factors	0 ..... + 0.99	1 ..... 255 s
over power factor	0 ..... - 0.99	1 ..... 255 s
current THD	5 ... 50%	5 ..... 255 s
voltage THD	5 ..... 50%	5 .....255 s
crest factor	1....3.000	1 ..... 255 s
form factor	1....3.000	1 ..... 255 s

**Waveform Memories:**

The metering function Plus offers two additional functions:

- Two independent waveform memories.
- Harmonic analysis.

The two independent waveform memories can be used to analyze the current and voltages values at the time of the event.

If the waveform memories are programmed to "recording" (standard setting), there is continuous recording until a previously defined event occurs. Then, the recording is stopped, and the current or voltage waveforms at the time of the event can be observed through a visual display (graphical LCD, laptop or PC). The time window is one second; the resolution is 1649 values/second.

The values that can be selected for one of the waveform memories are:

Currents	I L1, I L 2 , I L 3, I L N , I g
Voltages	UL1; UL2: UI3

The waveform memories can also be started or stopped individually through the communications channels (PROFIBUS-DP, MODBUS and Cubicle BUS).





**Breaker Data Adapter BDA:**

The BDA is the first circuit breaker parameterisation device with integrated web server for the local programming, operation and monitoring of the SENTRON WL and SENTRON VL. The data may be read out on any output device with browser capabilities(e.g. Notebook), without the need for special software. The only system requirement for the input / output device is a standard browser with JAVA2 virtual machine. Once the BDA is connected to the circuit breaker, the browser is filled with Web pages from BDA and the data of the circuit breaker as shown in the following pictures. In addition, the BDAPlus incorporates an Ethernet interface for direct connection to the Ethernet/Intranet/Internet.

**Switch ES Power:**

By means of the Switch ES Power software, the SENTRON WL and SENTRON VL circuit breakers can be parameterized, operated and monitored via PROFIBUS-DP. Operational philosophy of switches has been harmonized with that of the BDA. An object manager ensures complete integration into the SIMATIC world. Thus, SENTRON becomes an important component in Totally Integrated Automation(TIA).

**Power Management:**

SENTRON circuit breakers can be easily integrated into Power Management Systems. This facilitates efficient diagnosis, alarm, maintenance, cost center and load management. SENTRON circuit breakers play a key role in solutions provided by Totally Integrated Power(TIP).

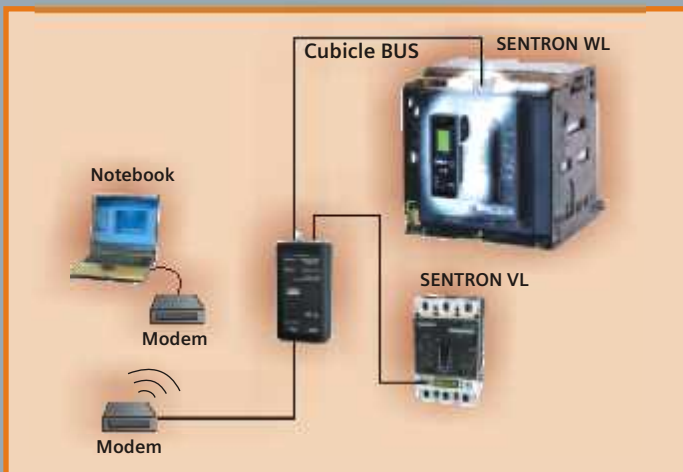

You can use modems to extend the serial connection from the notebook to the BDA to enable the circuit breaker data to be accessed irrespective of your geographical location

Breaker Data Adapter - diagnostics

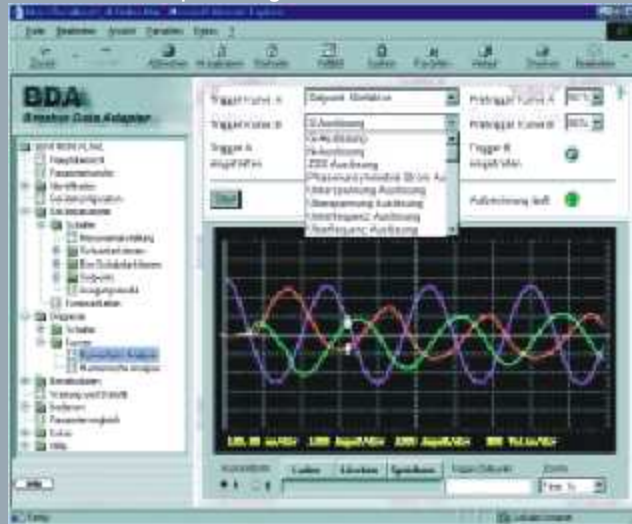

## Data that can be transmitted using COM15 / COM16 or the breaker data adapter



<b>Transmittable circuit breaker data</b>		
Order code (Order no. Of circuit breaker + "-Z" ) Order no.	F01 +BDA/BDA Plus order no.	F02/F12
<b>Application options</b>		
Transmission of circuit breaker data to PROFIBUS-DP or Modbus - TCP / IP Network and Integration in higher-level visualization system possible e.g. In PCS7 Power Management Systems, WinCC (Incl. Add Ons, such as SMS radio server)	—	✓
Transmission of circuit breaker data and software (i.e. HTML pages Incl. Data) to local output device or remotely controlled via the Ethernet/Intranet/Internet (no Integration option in higher-level visualization systems) e.g. for monitoring diagnostics, maintenance and configuration of individual circuit breaker	✓	—
Use of the functionality of all CubicleBUS modules E.g. Programming of the configurable digital output modules, status interrogation of digital input modules diagnostics, testing	✓	✓
<b>Transmittable circuit breaker data without integrated metering function</b>		
<b>Device Identification:</b> Communication address, circuit breaker order no., Circuit breaker characteristic data (Size no. Of poles, rated current module etc.) ID numbers, release type, free text for equipment identifier and comments	✓ ✓ <sup>1)</sup>	✓ ✓
<b>Operating states:</b> Closed / open signal spring store mechanism, tripped, readiness to close, Circuit breaker position (connected, test, disconnected and absent) for withdrawable circuit-breakers, PROFIBUS write protection on/off, free user input	✓ <sup>1)</sup> ✓ <sup>1)</sup> ✓ <sup>1)</sup>	✓ ✓ ✓
<b>Control commands</b> Closed / open circuit breakers, enable/disable free user output Reset trip signal Clear event and trip log Reset the min/max measured values, reset maintenance information	✓ <sup>1)</sup> ✓ <sup>1)</sup> ✓ <sup>1)</sup> ✓ <sup>1)</sup>	✓ ✓ ✓ ✓
<b>History</b> Readout of event log, readout of trip log	✓ <sup>1)</sup>	✓
<b>Maintenance Information</b> Number of L, S, I releases and total, contact erosion Number of switch operations under load and total operating hours	✓ <sup>1)</sup> ✓ <sup>1)</sup>	✓ ✓
<b>Event signaling</b> Trip signal with identificatio of the current casuing the trip Alarm signaling (e.g. Overload) with incoming/outgoing information All named event signaling with time stamp	✓ ✓ —	✓ ✓ ✓
<b>Configuration of protective functions</b> Readout of protective function parameters Change the settings of the protective function parameters through communication Parameter set changeover option (set A to set B)	✓ ✓ <sup>2)</sup> ✓ <sup>2)</sup>	✓ ✓ <sup>2)</sup> ✓ <sup>2)</sup>
<b>Measured values</b> Phase currents, each with min/max, value Temperature in the circuit breaker with min/max. value Temperature in the cubicle with min/max, value All named measured values with time stamp	✓ ✓ =	✓ ✓ ✓
<p>* 1) Possible in connections with the COM15 / COM16 Module (Bus connection not required)</p> <p>* 2) Possible with ETU 76B</p> <p><i>Additional transmittable circuit breaker data with integrated metering functions as mentioned on page 24, 25 &amp; 26</i></p>		

### Startup and Configuration:

- PROFIBUS-DP enables faster and more reliable connections than conventional point-to-point wiring. (Option with MODBUS also)
- Minimum plant down times for necessary expansion
- Simple startup test
- Transparent startup process with good documentation options
- Fast and reliable local configuration via PROFIBUS-DP or MODBUS or the Ethernet / Intranet / Internet with intelligent configuration software.

### Operator Control and Monitoring:

- Increase transparency in power distribution through transmission of current status information, alarm signals and set point monitoring.
- Fault management enables a fast response when leaving the normal state. Important message (e.g. trip signal and reasons) can be transmitted by SMS to the cell phone of the plant personnel.
- Options for the central readout of parameters and their automatic transmission to interchangeable circuit breakers minimizes fault liability and shortens down times.
- Effective diagnostics management e.g. through determinations of the precise cause of fault and recording of the phase current.
- Remote control of the circuit breaker enables both the manual and automatic switching on and off of plant parts.

### Power Management:

- The balancing of load peaks and troughs allows the realization of energy imports costs. Efficient load management enables the demand-orientated switching.
- Analysis of the archived power values (output curves) enables creation of a power consumption profile. This can be the basis for future power procurement.
- The quality of energy (harmonics, flickers) can be logged and documented. This enables effective power quality management.
- Cost center management makes power consumption more transparent for commercial analysis. Cost can be clearly assigned and optimized.

### Maintenance and Service:

- Information for preventive maintenance (e.g. number of switching operations, operating hours, contact erosion estimation) enables timely and calculated planning of necessary maintenance work. This reduces the risk of costly damage to sensitive plant parts.
- The central control of maintenance work and the ability to SMS key information considerably reduce costs for maintenance and service.

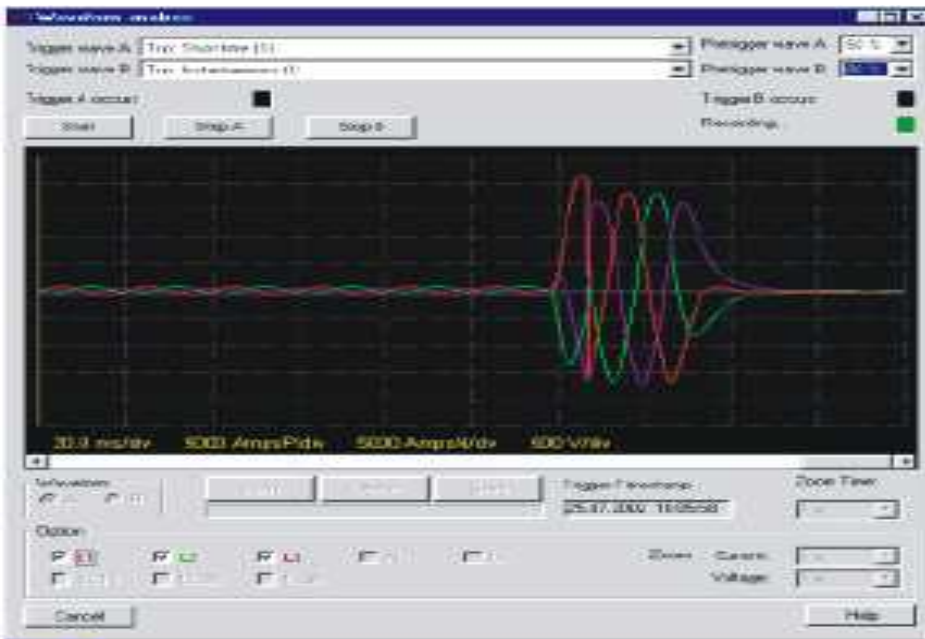

The two available waveform buffer enable currents and voltages to be recorded on an event controlled basis.

## Intelligent Simplicity - SENTRON

