

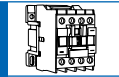

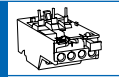

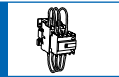

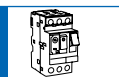



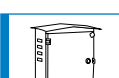
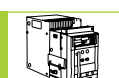
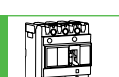
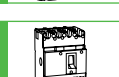

Industrial Circuit Protection

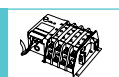

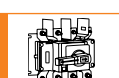
Catalogue 2016

Content

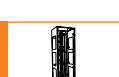
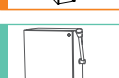
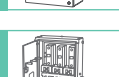
	Contactor	2-31	
	Thermal Overload Relay	32-45	
	Capacitor Duty Contactor	46-51	
	Motor Protection Circuit Breaker	52-59	
	Cosmic Motor Starter	60-75	
	Agri Motor Starter	76-81	
	Street Light Panel	82-91	
	Titania Air Circuit Breaker	92-111	
	Loadline Moulded Case Circuit Breaker	112-157	
	Loadline Digital Moulded Case Circuit Breaker	158-169	
	Loadbank MCCB Panel Board System	170-187	
	Euroload Changeover Switch	188-197	
	Euroload By-Pass Changeover Switch	198-201	
	Instaline Automatic Transfer Switch	202-211	
	Kompact Switch Disconnecter Fuse	212-221	
	Euroload Switch Disconnecter	222-229	
	HiBreak Fuse Link	230-237	
	HiBreak Din Fuse Base	238-243	
	CamLock Fuse Holder	244-249	
	Busbar Chamber System	250-255	
	General Purpose Load Changeover Switch	256-259	
	General Purpose Fuse Switch & Switch Fuse	260-266	

Contactors

Features:

Latest	: Fully application oriented conforming to IS/IEC - 60947 - 4 - 1
Wide Range	: CR, 9A – 630A (4kW- 375kW) in 13 frame sizes
System Design	: For a compact system building built in aux. contact 1NO / 1NC upto 32A and 1NO + 1NC from 40A to 95A
Execution	: 3P / 4P / 3P capacitor duty
Control	: AC / DC
Utilization Category	: 12 AC Duty Categories, 4 DC Duty Categories
Flexible	: Common add-on, side & Front mounted aux. contact & Accessories
Options	: Diagonal or same side wiring on coils upto 95A
Indian Conditions	: Liberal creepage distance & superior material grade
Safety	: Shrouded terminals to prevent accidental contact
Facility	: Din Rail mounting upto 95A & direct mounting with O/L Relays upto 95A
Modular design	: All accessories snap fitted
Conservation	: Low coil consumption

The “Cosmic Star” series of contactor and thermal overload relay are designed and manufactured to world class standards.

A perfect blend of aesthetics, features and performance.

The Cosmic Star Series covers contactor range from 9A – 630A in 3P & 4P execution and overload relays 0.1A – 93A in direct version and 30A – 630A in electronic version. These fully conform to both national & international standards namely IS/IEC-60947-4 - 1

The contactors provide reliable and safe switching and the thermal relays offer close & accurate protection against overload

The user friendly series comes with a wide range of add-on / optional accessories to meet varied application needs in motor, distribution circuits and automation systems.



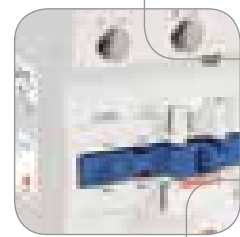
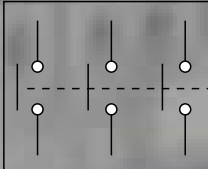

Standard conformity : IS/IEC - 60947 - 4 - 1
 Insulation voltage Ui : 750 V
 Operation voltage Ue : 690 V
 Ambient Temperature Range : -5 °C to +55 °C
 Operating Altitude : 3000 m
 Mounting Position : ±30° (Vertical Plane)



Contactor	Type CN* / CD*	CRN1 04	CN1 09	CN1 12	
Current Rating at 415V 50Hz AC3 -Ie	A	CR	9	12	
No. of poles		2NO+2NC, 3NO+1NC, 4NO	3P+1NO/1NC, 4P	3P+1NO/1NC, 4P	
Impulse withstand voltage Uimp	kV	6	6	6	
Making Capacity	A	Control Relay (AC-15 / DC-13 Duty)	250	250	
Breaking Capacity at 415V	A		250	250	
AC1 Duty : Rated Operational Current I _{th}	A		25	25	
Max. Power Rating at 415V	KW		11	11	
AC2 / AC3 Duty Rated Operational Current I _e	A		9	12	
Max. Power Rating at 415V For Electrical Life (Refer. electrical life plot)	KW/HP		4 / 5	5.5 / 7.5	
AC4 Duty : Rated Operational Current I _e	A		9	12	
Max. Power Rating at 415V For Electrical Life (Refer. electrical life plot)	KW/HP		4 / 5	5.5 / 7.5	
Mechanical Life	(Million Ops.)		10	10	10
Switching Frequency (No load)	Ops. / Hr.		3600	3600	3600
Impedence Per Pole	m.ohm.	7	2.5	2.5	
Short Time Current at 40°C (1sec.)	A	NA	245	245	
Short Circuit Back Up Fuse Rating	A	NA	20	20	
Max. Cable Size	Sq. mm	4	4	4	
Tightening torque	Nm	0.8	0.8	0.8	
Weight	3P	Kg.	0.34	0.34	
	4P	Kg.	0.34	0.34	
Over all Dimension (W x H x D)	3P	mm	45 x 74 x 82	45 x 74 x 82	
	4P	mm	45 x 74 x 82	45 x 74 x 82	
Control Circuit (AC Coil)					
Operating Voltage Range	V	0.7 - 1.1	0.7 - 1.1	0.7 - 1.1	
Power Consumption (inrush / hold) 50 Hz	VA	70/8	70/8	70/8	
Power Consumption (inrush / hold) 60 Hz	VA	80/8	80/8	80/8	
Heat Dissipation 50/60Hz	W	1.8-2.7	1.8-2.7	1.8-2.7	
Coil pickup time	ms	12-22	12-22	12-22	
Coil drop out time		5-12	5-12	5-12	

* CN : AC contactor with AC coil, *CD : AC contactor with DC coil.

Note: For dimension detail of CD series refer page no. 37

† : Weight of CN5 40 to CN6 95 is provided on request



CN2 18	CN3 25	CN4 32	CN5 40	CN5 50	CN5 65	CN6 80	CN6 95
18	25	32	40	50	65	80	95
3P+1NO/1NC, 4P	3P+1NO/1NC, 4P	3P+1NO/1NC, 4P	3P+1NO+1NC, 4P	3P+1NO+1NC, 4P	3P+1NO+1NC, 4P	3P+1NO+1NC, 4P	3P+1NO+1NC, 4P
6	6	6	8	8	8	8	8
330	450	560	760	900	950	1100	1120
330	450	560	760	900	950	1100	1120
32	40	50	60	80	80	125	125
18	22	25	33	45	45	63	63
18	25	32	40	50	65	80	95
9 / 12.5	11 / 15	15 / 20	22 / 30	25 / 35	37 / 50	45 / 60	45 / 60
18	25	32	40	50	65	80	95
9 / 12.5	11 / 15	15 / 20	22 / 30	25 / 35	37 / 50	45 / 60	45 / 60
10	10	10	8	8	8	6	6
3600	3600	3600	3000	3000	3000	2000	2000
2.5	2	2	1.5	1.5	1	0.8	0.8
320	435	545	735	875	920	1045	1065
32	40	50	63	80	80	100	125
6	10	10	16	25	25	50	50
0.8	1.2	1.2	3.5	3.5	3.5	4	4
0.35	0.5	0.52	1.08	1.08	1.08	1.3	1.3
-	0.5	-	†	†	†	†	†
47 x 76 x 87	57 x 83 x 95	57 x 83 x 100	77 x 120 x 116	77 x 120 x 116	77 x 120 x 116	87 x 120 x 127	87 x 120 x 127
-	57 x 83 x 95	-	85 x 120 x 116	85 x 120 x 116	85 x 120 x 116	96 x 120 x 127	96 x 120 x 127
0.7 - 1.1	0.7 - 1.1	0.7 - 1.1	0.7 - 1.1	0.7 - 1.1	0.7 - 1.1	0.75 - 1.1	0.75 - 1.1
110/11	110/11	110/11	200/20	200/20	200/20	200/20	200/20
115/11	115/11	115/11	200/20	200/20	200/20	200/20	200/20
2.5-3.5	3.0-4.0	6.0-10.0	6.0-10.0	6.0-10.0	6.0-10.0	6.0-10.0	6.0-10.0
12-22 5-12	15-24 5-20	15-24 5-20	20-25 8-15	20-25 8-15	20-25 8-15	20-35 10-20	20-35 10-20

Add-on Accessories

CN Series : AC (3 Pole / 4 Pole)

CD Series : DC (3 Pole / 4 Pole)



Contactor (IS/IEC - 60947-4-1) Type *	CRN1 04	CN1 09	CN1 12
Current Rating at 415V 50Hz AC3 -Ie A	4	9	12
Common Add-on Accessories			
Add-on Side / Front Mounted Aux. Contact Block Rated operational current at 240V / 415V - 6A / 4A Rated thermal current I_{th} - 10A Rated insulation voltage - 750V Duty - AC 15			
Contact Configuration		1NO+1NC	2NO
Type		CAS11	CAS20
Add-on Pneumatic Timer Block Type (ON Delay / OFF Delay) Time A - (0.1 -3s) / B - (0.1 - 30s) / C - (10 - 180s)			
Timer type	CPT1A / CPT1B / CPT1C		
Mechanical interlock			
Mechanical interlock Type	MN1234		
Thermal Overload Relay			
Overload Relay Type	RT21	RT11	
For Mounting with 3P / 4P Contactor Type :	CN1 09 to CN4 32		
Current Range in Amp. (Suffix Code No.)			
Features	0.1- 0.16 A	2.5-4 H	0.1- 0.16 A 2.5-4 H
• Protection against overload & single phasing	0.16- 0.25 B	4-6 J	0.16- 0.25 B 4-6 J
• Potential free trip contacts (1NO & 1NC)	0.25- 0.4 C	5.5-8 K	0.25- 0.4 C 5.5-8 K
• Ambient temperature compensated (-5°C to +55 °C)	0.4- 0.63 D	7-10 L	0.4- 0.63 D 7-10 L
• Auto - Manual reset / Manual reset facility	0.63-1.0 E	9-13 M	0.63-1.0 E 10-13 M
• Test mode facility	1-1.6 F	12-18 N	1-1.6 F 13-18 N
• Contactor mounting / Individual mounting with adaptor	1.6-2.5 G	17-25 P	1.6-2.5 G 18-25 P

* Side mounted aux. contact not applicable for 3P / 4P contactors with DC coil

* Mechanical interlock not applicable for 3P / 4P contactors with DC coil (9A - 95A)



CN2 18	CN3 25	CN4 32	CN5 40	CN5 50	CN5 65	CN6 80	CN6 95
18	25	32	40	50	65	80	95



1NO+1NC
CAF11

2NO+2NC
CAF22

3NO+1NC
CAF31

4NO
CAF40



CPT2A / CPT2B / CPT2C



MN56

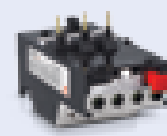
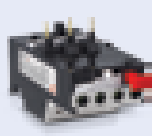

RT22

RT12

RT23

RT13

CN4 32 to CN5 65

CN5 40 to CN6 95

CN5 40 to CN6 95

23-32	Q	23-32	Q
28-36	R	30-40	R

23-32	T
30-40	U
37-50	V
48-65	W
55-70	X
63-80	Y
80-93	Z

38-50	V
48-57	W
57-66	X
63-80	Y

Standard conformity	: IS/IEC - 60947-4-1
Insulation voltage U_i	: 1000 V
Operation voltage U_e	: 1000 V
Ambient Temperature Range	: -5 °C to +55 °C
Operating Altitude	: 3000 m
Mounting Position	: $\pm 30^\circ$ (Vertical Plane)



Contactor	Type *	CH1 115	CH1 150	CH2 185	
Current Rating at 415V 50Hz AC3 -Ie	A	115	150	185	
No. of poles		3P, 4P	3P, 4P	3P, 4P	
Impulse withstand voltage U_{imp}	kV	8	8	8	
Making Capacity	A	1300	1700	2100	
Breaking Capacity at 415V	A	1300	1500	1800	
AC1 Duty : Rated Operational Current I_{th}	A	200	250	275	
Max. Power Rating at 415V	KW	110	140	152	
AC2 / AC3 Duty Rated Operational Current I_e	A	115	150	185	
Max. Power Rating at 415V For Electrical Life (Refer. electrical life plot)	KW/HP	59 / 75	80 / 100	100 / 125	
AC4 Duty : Rated Operational Current I_e	A	115	150	185	
Max. Power Rating at 415V For Electrical Life (Refer. electrical life plot)	KW/HP	59 / 75	80 / 100	100 / 125	
Mechanical Life	(Million Ops.)	3	3	3	
Switching Frequency (No load)	Ops. / Hr.	1800	1800	1800	
Impedence Per Pole	m.ohm.	0.37	0.35	0.33	
Short Time Current at 40°C (1sec.)	A	1235	1615	1995	
Short Circuit Back Up Fuse Rating	A	200	225	315	
Max. Cable Size	Sq. mm	95	120	150	
Tightening Torque	Nm	10	18	18	
Weight	3P	Kg.	3.45	3.45	4.5
	4P	Kg.	3.83	3.83	5.25
Over all Dimension (W x H x D)	3P	mm	164 x 162 x 171	164 x 170 x 171	168 x 174 x 181
	4P	mm	200 x 162 x 171	200 x 170 x 171	208 x 174 x 181
Control Circuit (AC Coil)					
Operating Voltage Range	V	0.75 - 1.1	0.75 - 1.1	0.75 - 1.1	
Power Consumption (inrush / hold) 50 Hz	VA	550 / 45	550 / 45	805 / 55	
Power Consumption (inrush / hold) 60 Hz	VA	660 / 55	660 / 55	970 / 66	
Heat Dissipation 50/60Hz	W	12 - 16	12 - 16	18 - 24	
Coil pickup time	ms	25-40	20-50	20-50	
Coil drop out time		10-15	10-30	10-30	

* CH Series, AC contactor suitable for both AC & DC coil.



CH2 225	CH3 265	CH4 330	CH5 400	CH6 500	CH7 630
225	265	330	400	500	630
3P, 4P	3P, 4P	3P, 4P	3P, 4P	3P, 4P	3P, 4P
8	8	8	8	8	8
2460	2740	3600	4500	5550	6740
2050	2450	3000	4000	5000	6300
315	350	400	500	700	1000
175	195	222	278	390	555
225	265	330	400	500	630
110 / 150	132 / 180	180 / 220	220 / 270	280 / 340	375 / 450
225	265	330	400	500	630
110 / 150	140 / 190	180 / 240	220 / 270	280 / 340	375 / 450
3	3	3	1	1	1
1800	1800	1500	1500	1500	1500
0.32	0.30	0.28	0.26	0.18	0.12
2340	2600	3420	4275	5270	6400
315	350	500	630	630	630
185	185	240	2X150	2X240	2(60X5) Busbar
35	35	35	35	35	58
4.6	7.28	8.20	9.10	11.35	18.60
5.20	8.25	9.5	10.20	12.95	21.50
168 x 197 x 181	201 x 203 x 213	213 x 206 x 219	213 x 206 x 219	233 x 238 x 232	309 x 304 x 255
208 x 197 x 181	248 x 203 x 213	261 x 206 x 219	261 x 206 x 219	288 x 238 x 232	389 x 304 x 255
0.75 - 1.1	0.75 - 1.1	0.75 - 1.1	0.75 - 1.1	0.75 - 1.1	0.75 - 1.1
805 / 55	1200 / 95	700 / 10	1075 / 15	1100 / 18	1650 / 22
970 / 66	1445 / 110	700 / 10	1075 / 15	1100 / 18	1650 / 22
18 - 24	8	8	14	18	20
20-50 10-30	20-50 10-30	20-50 10-30	20-50 10-30	20-50 10-30	20-50 10-30

Add-on Accessories

CH Series - AC / DC : (3 Pole / 4 Pole)



Contactor (IS / IEC : 60947-4-1) Type	CH1 115	CH1 150	CH2 185
Current Rating at 415V 50Hz AC3 -le A	115	150	185
Common Add-on Accessories			
Add-on Front Mounted Aux. Contact Block Rated operational current at 240V / 415V - 6A / 4A Rated thermal current I _{th} - 10A Rated insulation voltage - 750V Duty - AC 15			
Contact Configuration	←		1NO+1NC
Type			CAF11
Add-on Pneumatic Timer Block Type (ON Delay / OFF Delay) Time A - (0.1 -3s) / B - (0.1 - 30s) / C - (10 - 180s)			
Timer Type	←		CPT1A / CPT1B / CPT1C
Mechanical interlock type No.			
Mechanical interlock type No.	MH 1		
Electronic Overload Relay			
			
Overload Relay Type	ERT1 (Individual mounting)		
For Mounting with 3P / 4P Contactor Type :	CH1 115 to CH2 185		
Current Range in Amp. (Suffix Code No.)	30-50	ERT1 4 A	
	48-80	ERT1 4 B	
	60-100	ERT1 4 C	
	90-150	ERT1 4 D	
Features <ul style="list-style-type: none"> • Electronic Version • Protection against overload & single phasing • Potential free trip contacts (1NO & 1NC) • Ambient temperature compensated (-5°C to +55 °C) • Manual reset facility • Test mode facility • Individual mounting 			



CH2 225	CH3 265	CH4 330	CH5 400	CH6 500	CH7 630
225	265	330	400	500	630



2NO+2NC

CAF22

3NO+1NC

CAF31

4NO

CAF40



CPT2A / CPT2B / CPT2C



MH 2



MH 3 4 5



MH 6 7



ERT1 (Individual mounting)

CH2 185 to CH7 630

132-220

ERT1 5 E

200-330

ERT1 6 F

300-500

ERT1 6 G

380-630

ERT1 6 H

CN Series Contactors & Accessories

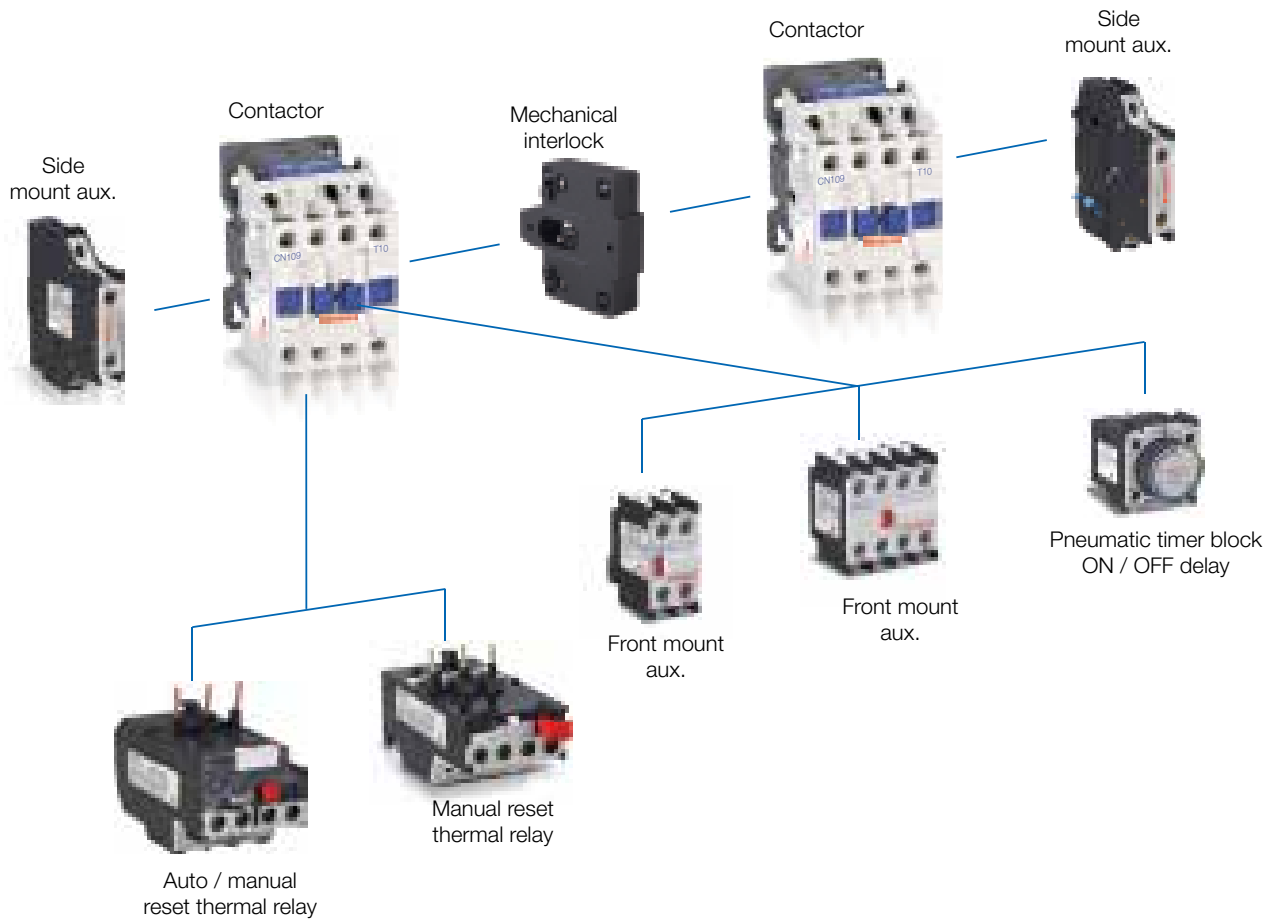

CH Series Contactors & Accessories

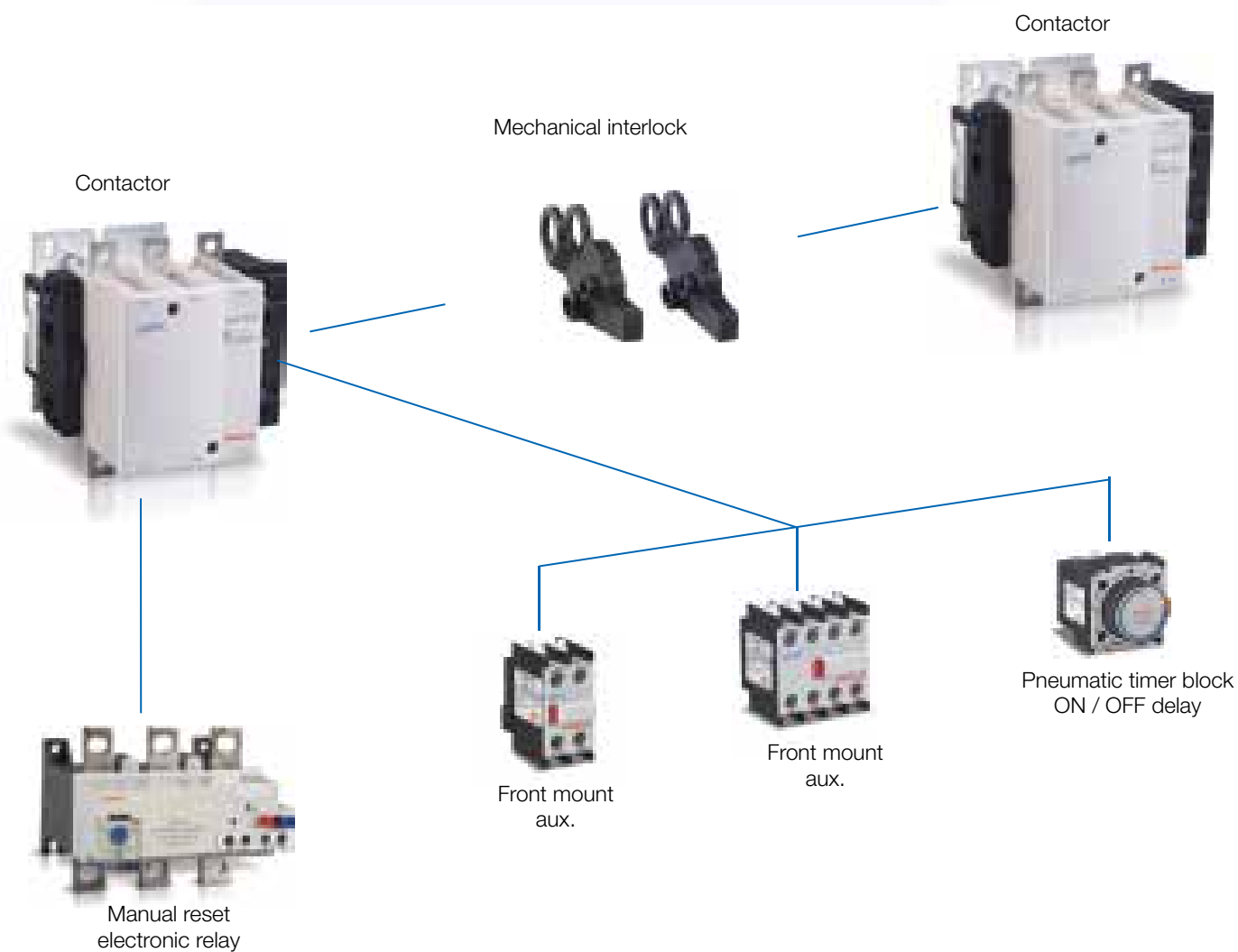

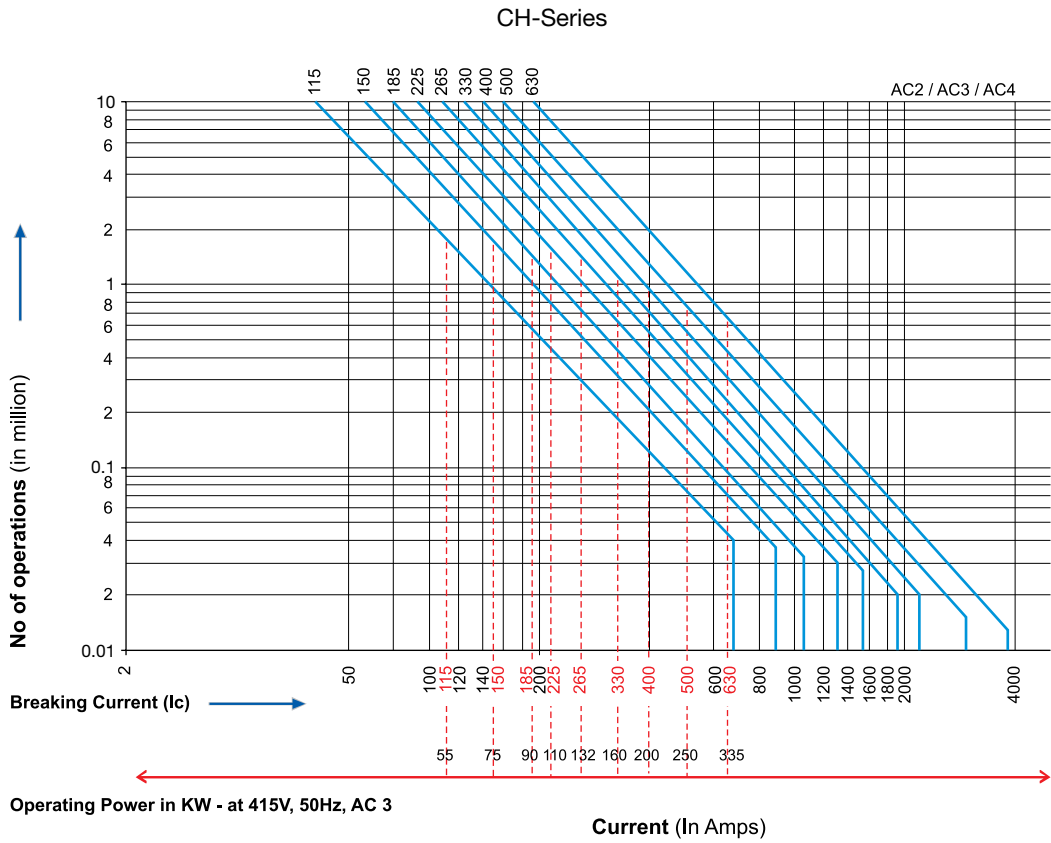
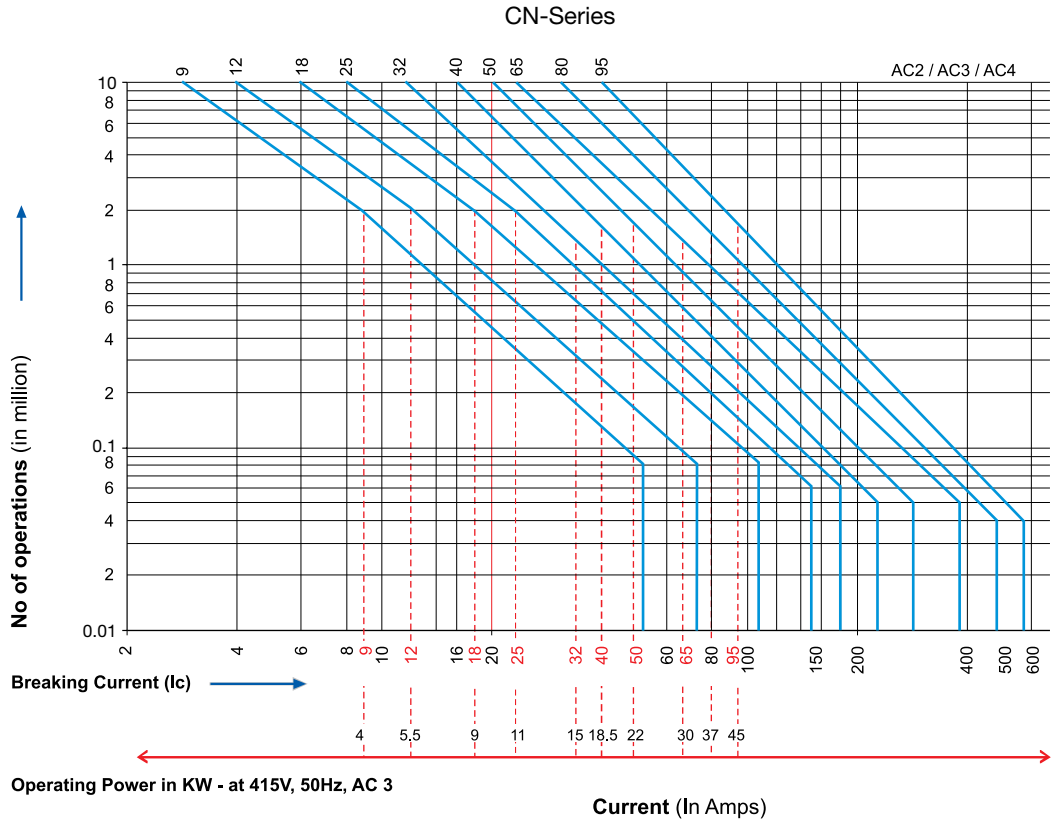

Operational Current & Power Rating

CN Frame												
Contactor Type			CN1 09	CN1 12	CN2 18	CN3 25	CN4 32	CN5 40	CN5 50	CN5 65	CN6 80	CN6 95
Max. Operational Current AC-3			9A	12A	18A	25A	32A	40A	50A	65A	80A	95A
U _e	220/240V	kW	2.2	3	4	5.5	7.5	11	15	18.5	22	25
		HP	3	4	5	7.5	10	15	20	25	30	35
U _e	380/400V	kW	4	5.5	7.5	11	15	18.5	22	30	37	45
		HP	5	7.5	10	15	20	25	30	40	50	60
U _e	415V	kW	4	5.5	9	11	15	22	25	37	40	45
		HP	5	7.5	12.5	15	20	30	35	50	65	60
U _e	440V	kW	4	5.5	9	11	15	22	30	37	45	45
		HP	5	7.5	12.5	15	20	30	35	50	60	60
U _e	500V	kW	5.5	7.5	10	15	18.5	22	30	37	55	55
		HP	7.5	10	12.5	20	25	30	40	50	75	75
U _e	660/690V	kW	5.5	7.5	10	15	18.5	30	33	37	55	55
		HP	7.5	10	12.5	20	25	40	40	50	75	75

CH Frame											
Contactor Type			CH1 115	CH1 150	CH2 185	CH2 225	CH3 265	CH4 330	CH5 400	CH6 500	CH7 630
Max. Operational Current AC-3			115A	150A	185A	225A	265A	330A	400A	500A	630A
U _e	220/240V	kW	30	40	55	63	75	100	110	147	200
		HP	40	50	75	85	100	125	150	180	250
U _e	380/400V	kW	55	75	90	110	132	160	220	265	335
		HP	75	100	110	150	180	220	250	340	430
U _e	415V	kW	59	80	100	110	132	180	220	280	375
		HP	75	100	125	150	180	220	270	340	450
U _e	440V	kW	59	75	90	110	132	200	250	295	375
		HP	75	100	125	150	180	250	340	400	450
U _e	500V	kW	75	90	110	129	160	200	250	355	400
		HP	100	110	150	180	220	250	340	430	450
U _e	660/690V	kW	80	100	110	129	160	220	280	335	450
		HP	100	125	150	180	220	270	340	430	470

Note : For U_e = 1000 V - operational current and power rating provided on request.

Standardized Utilization Categories

16

Standardized Utilization Categories according to IEC 60947-4-1 Specification

Utilization Category	I _e	Normal Duty						I _e	Occasional Duty					
		Make			Break				Make			Break		
		I/I _e	u/u _e	Cosφ	I/I _e	u/u _e	Cosφ		I/I _e	u/u _e	Cosφ	I/I _e	u/u _e	Cosφ
Alternate Current														
AC-1 Non inductive or slightly inductive loads, resistance furnaces	All values	1	1	0.95	1	1	0.95	All values	1.5	1.05	0.8	1.5	1.05	0.8
AC-2 Slip-ring motors starting, switching off	All values	2.5	1	0.65	2.5	1	0.65	All values	4(3)	1.05	0.65(3)	4(3)	1.05	0.65(3)
AC-3 Squirrel-cage motors: starting, switching off	I _e ≤ 17A	6	1	0.65	1	0.17	0.65	I _e ≤ 100A	10	1.05	0.45	8	1.05	0.45
AC-3 Squirrel-cage motors: starting, switching off	I _e > 17A	6	1	0.35	1	0.17	0.35	I _e > 100A	10	1.05	0.35	8	1.05	0.35
AC-4 Squirrel-cage motors: starting, plugging ⁽¹⁾ , inching ⁽¹⁾	I _e ≤ 17A	6	1	0.65	6	1	0.65	I _e ≤ 100A	12	1.05	0.45	10	1.05	0.45
AC-4 Squirrel-cage motors: starting, plugging ⁽¹⁾ , inching ⁽¹⁾	I _e > 17A	6	1	0.35	6	1	0.35	I _e > 100A	12	1.05	0.35	10	1.05	0.35
AC-5a Switching of electric discharge lamp controls	All values	2	1	0.45	1	1	0.45	All values	3	1.05	0.45	3	1.05	0.45
AC-5b Switching of incandescent lamps	All values	1	1	(4)	1	1	(4)	All values	1.5	1.05	(4)	1.5	1.05	(4)
AC-6a Switching of transformers	All values	under examination						All values	Refer table 7b of IEC 60947-4-1					
AC-6b Switching of capacitor banks	All values	under examination						All values						
Direct Current		I _e	u/u _e	L/R(ms)	I _e	u/u _e	L/R(ms)		I _e	u/u _e	L/R(ms)	I _e	u/u _e	L/R(ms)
DC-1 Non-inductive or slightly inductive loads, resistance furnaces.	All values	1	1	1	1	1	1	All values	1.5	1.05	1	1.5	1.05	1
DC-3 Shunt-motors : starting, plugging ⁽¹⁾ inching ⁽²⁾ , dynamic breaking of DC motors	All values	2.5	1	2	2.5	1	2	All values	4	1.05	2.5	4	1.05	2.5
DC-5 Series-motors: starting, plugging ⁽¹⁾ inching ⁽¹⁾ , dynamic braking of DC motors	All values	2.5	1	7.5	2.5	1	7.5	All values	4	1.05	15	4	1.05	15
DC-6 Switching of incandescent lamps.	All values	1	1	(4)	1	1	(4)	All values	1.5	1.05	(4)	1.5	1.05	(4)
Control Circuit Devices (IEC 60947-5-1)		I/I _e	u/u _e	Cos φ	I/I _e	u/u _e	Cos φ		I/I _e	u/u _e	Cos φ	I/I _e	u/u _e	Cos φ
AC-14 Control of small electromagnetic loads (≤72VA)	All values	6	1	0.3	1	1	0.3	All values	6	1.1	0.7	6	1.1	0.7
AC-15 control of electromagnetic loads (> 72 VA)	All values	10	1	0.3	1	1	0.3	All values	10	1.1	0.3	10	1.1	0.3
Direct Current		I/I _e	u/u _e	To.95	I/I _e	u/u _e	To.95		I/I _e	u/u _e	To.95	I/I _e	u/u _e	To.95
DC-13 Control of electromagnets	All values	1	1	6P(5)	1	1	6P(5)	All values	1.1	1.1	6P(5)	1.1	1.1	6P(5)

Each utilization category is characterized by the values of the current to be made and switched (expressed as multiples of the rated operational current) and by the relevant voltages, power factor (AC duties) or time constant (DC duties) under normal or occasional conditions.

I - Applied current

U - applied voltage

Cos φ - Power factor

I_e - rated operational current

U_e - Rated operational voltage

L/R - time constant

Note:

1. Plugging is understood to be stopping or reversing the motor rapidly by reversing motor primary connections while the motor is running.
2. Inching (jogging) is referred to energizing a motor once or repeated by short periods to obtain small movements of the driven mechanism.
3. Values indicated apply to stator contactors. For rotor contactors, a test will be carried out with a current value equivalent to 4 times the rotor rated current & with Cos φ = 0.95
4. Test carried out with a load of incandescent lamps
5. The value 6P(W) is obtained from an empirical formula & represents the significant part of the D.C. magnetic loads upto the top limit of P=50W or 6P=300ms. Loads having an energy consumption over 50W are constituted by parallel lower wattage loads, consequently, 300ms must be considered a top limit whatever is the value of Power consumption.

Motor Currents

Average full-load currents of 3-phase squirrel cage motors, 3-phase 4-pole motors, 50/60 Hz

Power		Motor Currents												
kW	HP	200 / 208 V	220 V	230 V (1)	380 V	400 V	415 V	433 / 440 V	460 V (1)	500 / 525 V	575 V (1)	660 V	690 V	750 V
		A	A	A	A	A	A	A	A	A	A	A	A	A
0.37	0.5	2	1.8	2	1.03	0.98	-	0.99	1	1	0.8	0.6	-	-
0.55	0.75	3	2.75	2.8	1.6	1.5	-	1.36	1.4	1.21	1.1	0.9	-	-
0.75	1	3.8	3.5	3.6	2	1.9	2	1.68	1.8	1.5	1.4	1.1	-	-
1.1	1.5	5	4.4	5.2	2.6	2.5	2.5	2.37	2.6	2	2.1	1.5	-	-
1.5	2	6.8	6.1	6.8	3.5	3.4	3.5	3.06	3.4	2.6	2.7	2	-	-
2.2	3	9.6	8.7	9.6	5	4.8	5	4.42	4.8	3.8	3.9	2.8	-	-
3	-	12.6	11.5	-	6.6	6.3	6.5	5.77	-	5	-	3.8	-	-
-	5	-	-	15.2	-	-	-	-	7.6	-	6.1	-	-	-
4	-	16.2	14.5	-	8.5	8.1	8.4	7.9	-	6.5	-	4.9	-	-
5.5	7.5	22	20	22	11.5	11	11	10.4	11	9	9	6.6	-	-
7.5	10	28.8	27	28	15.5	14.8	14	13.7	14	12	11	6.9	-	-
9	-	36	32	-	18.5	18.8	17	16.9	-	13.9	-	10.6	-	-
11	15	42	39	42	22	21	21	20.1	21	18.4	17	14	12.1	11
15	20	57	52	54	30	28.5	28	26.5	27	23	22	17.3	16.5	15
18.5	25	70	64	68	47	35	35	32.8	34	28.5	27	21.9	20.2	18.5
22	30	84	75	80	44	42	40	39	40	33	32	25.4	24.2	22
30	40	114	103	104	60	57	55	51.5	52	45	41	54.6	33	30
37	50	138	126	130	72	69	66	64	65	55	52	42	40	36
45	60	162	150	154	85	81	80	76	77	65	62	49	46.8	42
55	75	200	182	192	105	100	100	90	96	80	77	61	58	52
75	100	270	240	248	138	131	135	125	124	105	99	82	75.7	69
90	125	330	295	312	170	162	165	146	156	129	125	98	94	85
110	150	400	356	360	205	195	200	178	180	156	144	118	113	103
132	-	480	425	-	245	233	240	215	-	187	-	140	135	123
-	200	520	472	480	273	222	260	236	240	207	192	152	128	136
160	-	560	520	-	300	285	280	256	-	220	-	170	165	150
-	250	-	-	600	-	-	-	-	300	-	240	200	-	-
200	-	680	626	-	370	252	340	325	-	281	-	215	203	185
220	300	770	700	720	408	388	385	353	360	310	288	235	224	204
250	350	850	800	840	460	437	425	401	420	360	336	274	253	230
280	-	-	-	-	528	-	-	-	-	-	-	-	-	-
315	-	1070	990	-	584	555	535	505	-	445	-	337	321	292
-	450	-	-	1080	-	-	-	-	540	-	432	-	-	-
355	-	-	1150	-	635	605	580	549	-	500	-	370	350	318
-	500	-	-	1200	-	-	-	-	600	-	480	-	-	-
400	-	-	1250	-	710	675	650	611	-	540	-	410	390	356
450	600	-	-	1440	-	-	-	-	720	-	576	-	-	-
500	-	-	-1570	-	900	855	820	780	-	680	-	515	494	450
560	-	-	1760	-	1000	950	920	870	-	760	-	575	549	500
630	-	-	1980	-	1100	1045	1020	965	-	850	-	645	605	550
710	-	-	-	-	1260	1200	1140	1075	-	960	-	725	694	630

These values are given as a guide. They may vary depending on the type of motor and manufacturer.
(1) values conforming to the NEC (National Electrical Code).

Ordering Information

18



Control Relay with AC Coil					
Frame size	I _{th}	Contact arrangement		Type	Cat. No
		NO	NC		
1	10A	2	2	CRN1-22*	IHACR 22*
		3	1	CRN1-31*	IHACR 31*
		4	0	CRN1-40*	IHACR 40*



Control Relay with DC Coil					
Frame size	I _{th}	Contact arrangement		Type	Cat. No
		NO	NC		
1	10A	2	2	CRD1-22*	IHDCR 22*
		3	1	CRD1-31*	IHDCR 31*
		4	0	CRD1-40*	IHDCR 40*



Contactor 3-Pole with AC Coil (9A to 95A)									
Frame Size	AC-3 Duty Rating at 415V, 50 Hz			AC-1 Duty Rating at 415V, 50 Hz	Power Poles	Auxiliary Contact Arrangement		Type	Cat. No
	I _e Amp.	Kw.	HP	I _{th} Amp.		NO	NC		
1	9	4	5.0	25	3	1	0	CN1 09 T10*	IHPAA009110*
	9	4	5.0	25	3	0	1	CN1 09 T01*	IHPAA009101*
	12	5.5	7.5	25	3	1	0	CN1 12 T10*	IHPAA012110*
	12	5.5	7.5	25	3	0	1	CN1 12 T01*	IHPAA012101*
2	18	9	12.5	32	3	1	0	CN2 18 T10*	IHPAA018210*
	18	9	12.5	32	3	0	1	CN2 18 T01*	IHPAA018201*
3	25	11	15	40	3	1	0	CN3 25 T10*	IHPAA025310*
	25	11	15	40	3	0	1	CN3 25 T01*	IHPAA025301*
4	32	15	20	50	3	1	0	CN4 32 T10*	IHPAA032410*
	32	15	20	50	3	0	1	CN4 32 T01*	IHPAA032401*
5	40	22	30	60	3	1	1	CN5 40 T11*	IHPAA040511*
	50	25	35	80	3	1	1	CN5 50 T11*	IHPAA050511*
	65	37	50	80	3	1	1	CN5 65 T11*	IHPAA065511*
6	80	45	60	125	3	1	1	CN6 80 T11*	IHPAA080611*
	95	45	60	125	3	1	1	CN6 95 T11*	IHPAA095611*



Contactor 3-Pole with AC coil (115A to 630A)							
Frame Size	AC-3 Duty Rating at 415V, 50 Hz			AC-1 Duty Rating at 415V, 50 Hz	Power Poles	Type	Cat. No
	I _e Amp.	Kw.	HP	I _{th} Amp.			
1	115	59	75	200	3	CH1 115 T*	IHPAA115100*
	150	80	100	250	3	CH1 150 T*	IHPAA150100*
2	185	100	125	275	3	CH2 185 T*	IHPAA185200*
	225	110	150	315	3	CH2 225 T*	IHPAA225200*
3	265	132	180	350	3	CH3 265 T*	IHPAA265300*
4	330	180	220	400	3	CH4 330 T*	IHPAA330400*
5	400	220	270	500	3	CH5 400 T*	IHPAA400500*
6	500	280	340	700	3	CH6 500 T*	IHPAA500600*
7	630	375	450	1000	3	CH7 630 T*	IHPAA630700*

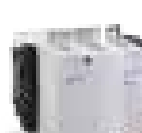
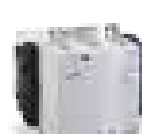

*To complete the Cat no. suffix the coil voltage from the coil voltage table

- Note:**
- For additional aux. contacts front/side mounted and mechanical interlock refer add-on accessories table.
 - Non standard coil voltages are supplied on request.

AC Coils								
Code*	A	C	E	G	H	J	K	N
AC Voltage	24V	48V	110V	220V	240V	380V	415V	550V





Contactor 4-Pole with AC Coil (9A to 95A)							
Frame Size	AC-1 Duty Rating at 415V , 50 Hz	AC-3 Duty Rating at 415V , 50 Hz			Power Poles	Type	Cat. No
	I _{th} Amp.	I _e Amp.	Kw.	HP			
1	25	12	5.5	7.5	4	CN1 12 F*	IHPAC012100*
3	40	25	11	15	4	CN3 25 F*	IHPAC025300*
5	60	40	22	30	4	CN5 40 F*	IHPAC040500*
	80	65	37	50	4	CN5 65 F*	IHPAC065500*
6	125	95	45	60	4	CN6 95 F*	IHPAC095600*

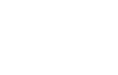

Contactor 4-Pole with AC coil (115A to 630A)							
Frame Size	AC-1 Duty Rating at 415V , 50 Hz	AC-3 Duty Rating at 415V , 50 Hz			Power Poles	Type	Cat. No
	I _{th} Amp.	I _e Amp.	Kw.	HP			
1	200	115	59	75	4	CH1 115 F*	IHPAC115100*
	250	150	80	100	4	CH1 150 F*	IHPAC150100*
2	275	185	100	125	4	CH2 185 F*	IHPAC185200*
	315	225	110	150	4	CH2 225 F*	IHPAC225200*
3	350	265	132	180	4	CH3 265 F*	IHPAC265300*
4	400	330	180	220	4	CH4 330 F*	IHPAC330400*
5	500	400	220	270	4	CH5 400 F*	IHPAC400500*
6	700	500	280	340	4	CH6 500 F*	IHPAC500600*
7	1000	630	375	450	4	CH7 630 F*	IHPAC630700*

*To complete the Cat no. suffix the coil voltage from the coil voltage table

- Note:
1. For additional aux. contacts front/side mounted and mechanical interlock refer add-on accessories table.
 2. Non standard coil voltages are supplied on request.



AC Coils								
Code*	A	C	E	G	H	J	K	N
AC Voltage	24V	48V	110V	220V	240V	380V	415V	550V

Contactor 3 Pole with DC Coil (9A to 95A)									
Frame Size	AC-3 Duty Rating at 415V , 50 Hz			AC-1 Duty Rating at 415V , 50 Hz	Power Poles	Auxilliary Contact Arrangement		Type	Cat. No
	I _e Amp.	Kw.	HP	I _{th} Amp.		NO	NC		
1	9	4	5.0	25	3	1	0	CD1 09 T10*	IHPAB009110*
	9	4	5.0	25	3	0	1	CD1 09 T01*	IHPAB009101*
	12	5.5	7.5	25	3	1	0	CD1 12 T10*	IHPAB012110*
	12	5.5	7.5	25	3	0	1	CD1 12 T01*	IHPAB012101*
2	18	9	12.5	32	3	1	0	CD2 18 T10*	IHPAB018210*
	18	9	12.5	32	3	0	1	CD2 18 T01*	IHPAB018201*
3	25	11	15	40	3	1	0	CD3 25 T10*	IHPAB025310*
	25	11	15	40	3	0	1	CD3 25 T01*	IHPAB025301*
4	32	15	20	50	3	1	0	CD4 32 T10*	IHPAB032410*
	32	15	20	50	3	0	1	CD4 32 T01*	IHPAB032401*
5	40	22	30	60	3	1	1	CD5 40 T11*	IHPAB040511*
	50	25	35	80	3	1	1	CD5 50 T11*	IHPAB050511*
	65	37	50	80	3	1	1	CD5 65 T11*	IHPAB065511*
6	80	45	60	125	3	1	1	CD6 80 T11*	IHPAB080611*
	95	45	60	125	3	1	1	CD6 95 T11*	IHPAB095611*

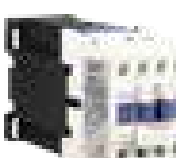
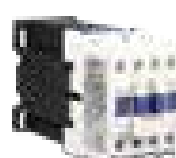
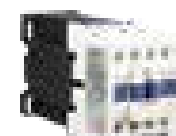
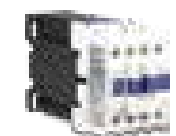





Contactor 3 Pole with DC coil (115A to 630A)							
Frame Size	AC-3 Duty Rating at 415V , 50 Hz			AC-1 Duty Rating at 415V , 50 Hz	Power Poles	Type	Cat. No
	I _e Amp.	Kw.	HP	I _{th} Amp.			
1	115	59	75	200	3	CH1 115 T*	IHPAB115100*
	150	80	100	250	3	CH1 150 T*	IHPAB150100*
2	185	100	125	275	3	CH2 185 T*	IHPAB185200*
	225	110	150	315	3	CH2 225 T*	IHPAB225200*
3	265	132	180	350	3	CH3 265 T*	IHPAB265300*
4	330	180	220	400	3	CH4 330 T*	IHPAB330400*
5	400	220	270	500	3	CH5 400 T*	IHPAB400500*
6	500	280	340	700	3	CH6 500 T*	IHPAB500600*
7	630	375	450	1000	3	CH7 630 T*	IHPAB630700*

*To complete the Cat no. suffix the coil voltage from the coil voltage table
 Note: 1. For additional aux. contacts, front mounted refer add-on accessories table.
 2. Non standard coil voltages are supplied on request.

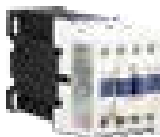
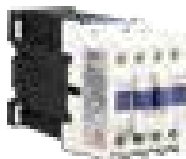

DC Coils				
Code*	A	C	E	G
DC Voltage	24V	48V	110V	220V

Contactor 4-Pole with DC Coil (9A to 95A)								
Frame Size	AC-1 Duty Rating at 415V , 50 Hz	AC-3 Duty Rating at 415V , 50 Hz			Power Poles	Type	Cat. No	
	I _{th} Amp.	I _e Amp.	Kw.	HP				
1	25	12	5.5	7.5	4	CD1 12 F*	IHPAD012100*	
3	40	25	11	15	4	CD3 25 F*	IHPAD025300*	
5	60	40	22	30	4	CD5 40 F*	IHPAD040500*	
	80	65	37	50	4	CD5 65 F*	IHPAD065500*	
6	125	95	45	60	4	CD6 95 F*	IHPAD095600*	

*To complete the Cat no. suffix the coil voltage from the coil voltage table

- Note:
1. For additional aux. contacts, front mounted refer add-on accessories table.
 2. Non standard coil voltages are supplied on request.

DC Coils				
Code*	A	C	E	G
DC Voltage	24V	48V	110V	220V





Contactors 4-Pole with DC coil (115A to 630A)							
Frame Size	AC-1 Duty Rating at 415V , 50 Hz	AC-3 Duty Rating at 415V , 50 Hz			Power Poles	Type	Cat. No
	I _{th} Amp.	I _e Amp.	Kw.	HP			
1	200	115	59	75	4	CH1 115 F*	IHPAD115100*
	250	150	80	100	4	CH1 150 F*	IHPAD150100*
2	275	185	100	125	4	CH2 185 F*	IHPAD185200*
	315	225	110	150	4	CH2 225 F*	IHPAD225200*
3	350	265	132	180	4	CH3 265 F*	IHPAD265300*
4	400	330	180	220	4	CH4 330 F*	IHPAD330400*
5	500	400	220	270	4	CH5 400 F*	IHPAD400500*
6	700	500	280	340	4	CH6 500 F*	IHPAD500600*
7	1000	630	375	450	4	CH7 630 F*	IHPAD630700*

*To complete the Cat no. suffix the coil voltage from the coil voltage table

- Note: 1. For additional aux. contacts, front mounted refer add-on accessories table.
2. Non standard coil voltages are supplied on request.



DC Coils				
Code*	A	C	E	G
DC Voltage	24V	48V	110V	220V

Add on Accessories: Auxilliary Contact Block

Description	Suitable for Mounting on Contactors	Contact Configuration		Type	Cat No.
		NO	NC		
Side Block	CN Frame size 1-6 9A-95A 3P/4P	1	1	CAS11	ISPNASM611
		2	0	CAS20	ISPNASM620
Front Block	CN/CD Frame size 1-6 9A-95A 3P/4P & CH Frame Size 1-7 115A-630A 3P / 4P	1	1	CAF11	ISPNAFM711
		2	2	CAF22	ISPNAFM722
		3	1	CAF31	ISPNAFM731
		4	0	CAF40	ISPNAFM740

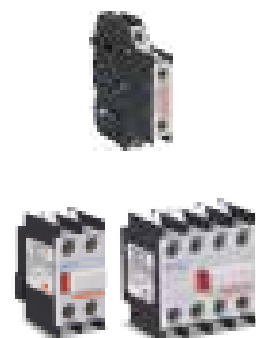
Add on Accessories: Pneumatic Timer Block

ON Delay	Suitable for Mounting on Contactors	Type	Cat No.
0.1 -3s	CN/CD/CH 9A-630A	CPT1A	IHNN4000
0.1-30s		CPT1B	IHNN5000
10-180s		CPT1C	IHNN6000

Add on Accessories: Pneumatic Timer Block

OFF Delay	Suitable for Mounting on Contactors	Type	Cat No.
0.1 -3s	CN/CD/CH 9A-630A	CPT2A	IHNF4000
0.1-30s		CPT2B	IHNF5000
10-180s		CPT2C	IHNF6000

Mechanical Interlock Site Fitment Type

Suitable for Mounting on Contactors	Type	Cat No.
CN1 to CN4	MN 1 2 3 4	ISPNM4SV
CN5 to CN6	MN 5 6	ISPNM6SV
CH1	MH 1	ISPHM1SV
CH2	MH 2	ISPHM2SV
CH3, CH4, CH5	MH 3 4 5	ISPHM5SV
CH6, CH7	MH 6 7	ISPHM7SV





Spare Coils (AC)

For use of Contactor type (3 Pole)	Type	Cat. No.
CRN1, CN1 09, CN1 12, CN2 18	CX1-2*	ISPNCN2*
CN3 25, CN4 32	CX1-4*	ISPNCN4*
CN5 40, CN5 50, CN5 65, CN6 80, CN6 95	CX1-6*	ISPNCN6*
CH1 115, CH1 150	CY1-1*	ISPNCN1*
CH2 185, CH2 225	CY1-2*	ISPNCN2*
CH3 265	CY1-3*	ISPNCN3*
CH4 330	CY1-4*	ISPNCN4*
CH5 400	CY1-5*	ISPNCN5*
CH6 500	CY1-6*	ISPNCN6*
CH7 630	CY1-7*	ISPNCN7*

*To complete the type/ cat no. suffix the coil voltage from the coil voltage table

Spare Coils (AC)

For use of Contactor type (4 Pole)	Type	Cat. No.
CRN1, CN1 09, CN1 12	CX1-2*	ISPNCN2*
CN3 25	CX1-4*	ISPNCN4*
CN5 40, CN5 50, CN5 65, CN6 80, CN6 95	CX1-6*	ISPNCN6*
CH1 115, CH1 150	CY1-1*	ISPNCN1*
CH2 185, CH2 225	CY1-2*	ISPNCN2*
CH3 265	CY1-3*	ISPNCN3*
CH4 330	CY1-4*	ISPNCN4*
CH5 400	CY1-5*	ISPNCN5*
CH6 500	CY1-6*	ISPNCN6*
CH7 630	CY1-7*	ISPNCN7*

*To complete the type/ cat no. suffix the coil voltage from the coil voltage table

AC Coils

Code*	A	C	E	G	H	J	K
AC Voltage	24V	48V	110V	220V	240V	380V	415V

Spare Coils (DC)		
For use of Contactor type (3 Pole)	Type	Cat. No.
CRD1, CD1 09, CD1 12, CD2 18	CX4-2*	ISPNDN2*
CD3 25, CD4 32	CX4-4*	ISPNDN4*
CD5 40, CD5 50, CD5 65, CD6 80, CD6 95	CX4-6*	ISPNDN6*
CH1 115, CH1 150	CY4-1*	ISPNDH1*
CH2 185, CH2 225	CY4-2*	ISPNDH2*
CH3 265, CH4 330	CY4-34*	ISPNDH34*
CH5 400	CY4-5*	ISPNDH5*
CH6 500	CY4-6*	ISPNDH6*
CH7 630	CY4-7*	ISPNDH7*

*To complete the type/ cat no. suffix the coil voltage from the coil voltage table



Spare Coils (DC)		
For use of Contactor type (4 Pole)	Type	Cat. No.
CRD1, CD1 09, CD1 12	CX4-2*	ISPNDN2*
CD3 25	CX4-4*	ISPNDN4*
CD5 40, CD5 50, CD5 65, CD6 80, CD6 95	CX4-6*	ISPNDN6*
CH1 115, CH1 150	CY4-1*	ISPNDH1*
CH2 185, CH2 225	CY4-2*	ISPNDH2*
CH3 265	CY4-3*	ISPNDH3*
CH4 330	CY4-4*	ISPNDH4*
CH5 400	CY4-5*	ISPNDH5*
CH6 500	CY4-6*	ISPNDH6*
CH7 630	CY4-7*	ISPNDH7*

*To complete the type/ cat no. suffix the coil voltage from the coil voltage table



DC Coils				
Code*	A	C	E	G
DC Voltage	24V	48V	110V	220V

Dimension (in mm)

CN series AC contactor with AC coil - 3 Pole / 4 Pole

28

CN1 09 - CN4 32

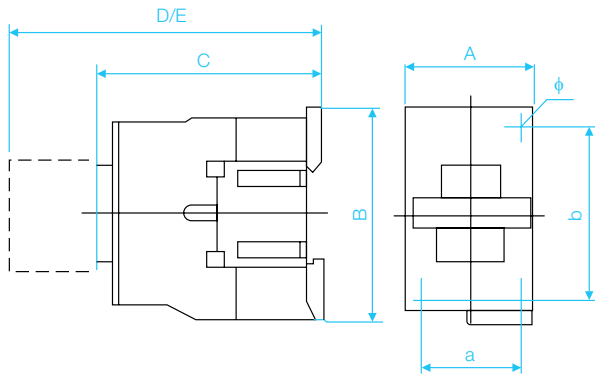

CN5 40 - CN6 95

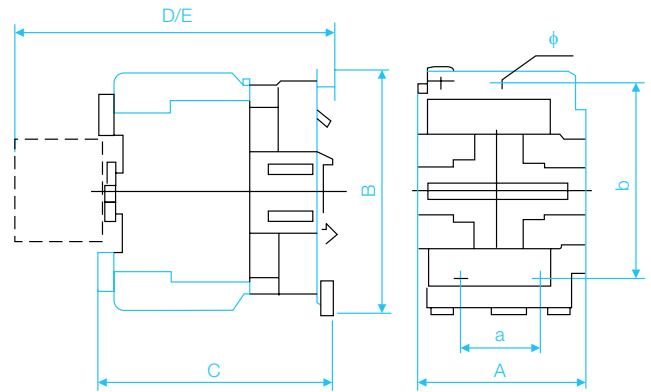

Dimension Detail

Type No		A	B	C	D	E	a	b	Φ
CN1 9-12	3P	45	74	82	113	133	34/35	50/60	4.5
	4P	45	74	82	113	133	34/35	50/60	4.5
CN2 18	3P	47	76	87	118	138	34/35	50/60	4.5
CN3 25	3P	57	83	95	126	146	40	48	4.5
	4P	57	83	95	126	146	40	48	4.5
CN4 32	3P	57	83	100	131	151	40	48	4.5
CN5 40-65	3P	77	120	116	145	165	40	100/110	6.5
	4P	85	120	116	145	165	40	100/110	6.5
CN6 80-95	3P	87	120	127	175	195	40	100/110	6.5
	4P	96	120	127	175	195	40	100/110	6.5

D: With front add on block

E: With pneumatic timer block

Note: Dimension of CRN1 same as CN1 9-12

Dimension (in mm)

CD series DC contactor with DC coil - 3 Pole / 4 Pole

CD1 9 - CD4 32

CD5 40 - CD6 95

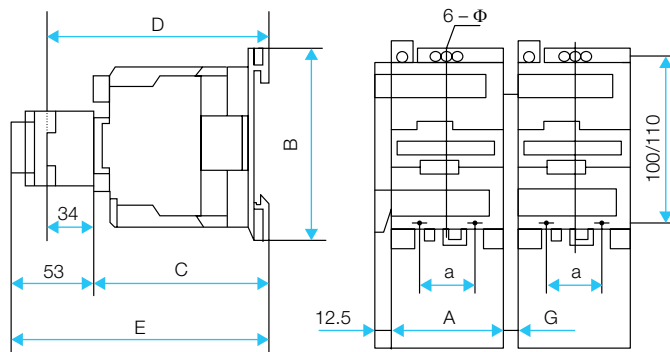
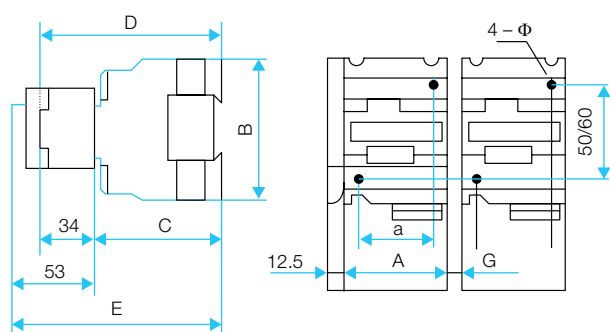

Dimension, in mm

Type No		A	B	C	D	E	a	Φ	G
CD1 9-12	3P	45	74	119	153	172	35	4.5	15
	4P	45	74	119	153	172	35	4.5	15
CD2 18	3P	47	76	125	159	178	35	4.5	15
CD3 25	3P	57	83	135	169	188	40	4.5	15
	4P	57	83	135	169	188	40	4.5	15
CD4 32	3P	57	83	140	174	193	40	4.5	15
CD5 40-65	3P	77	120	200	234	253	40	6.5	15
	4P	85	120	200	234	253	40	6.5	15
CD6 80-95	3P	87	120	215	249	268	40	6.5	15
	4P	96	120	215	249	268	40	6.5	15

D: With front add on block

E: With pneumatic timer block

G: Interlocking mechanism

Note: Dimension of CRD1 same as CD1 9-12

Dimension (in mm)

CH series AC contactor with AC / DC coil - 3 Pole / 4 Pole

CH1 115 - CH4 330

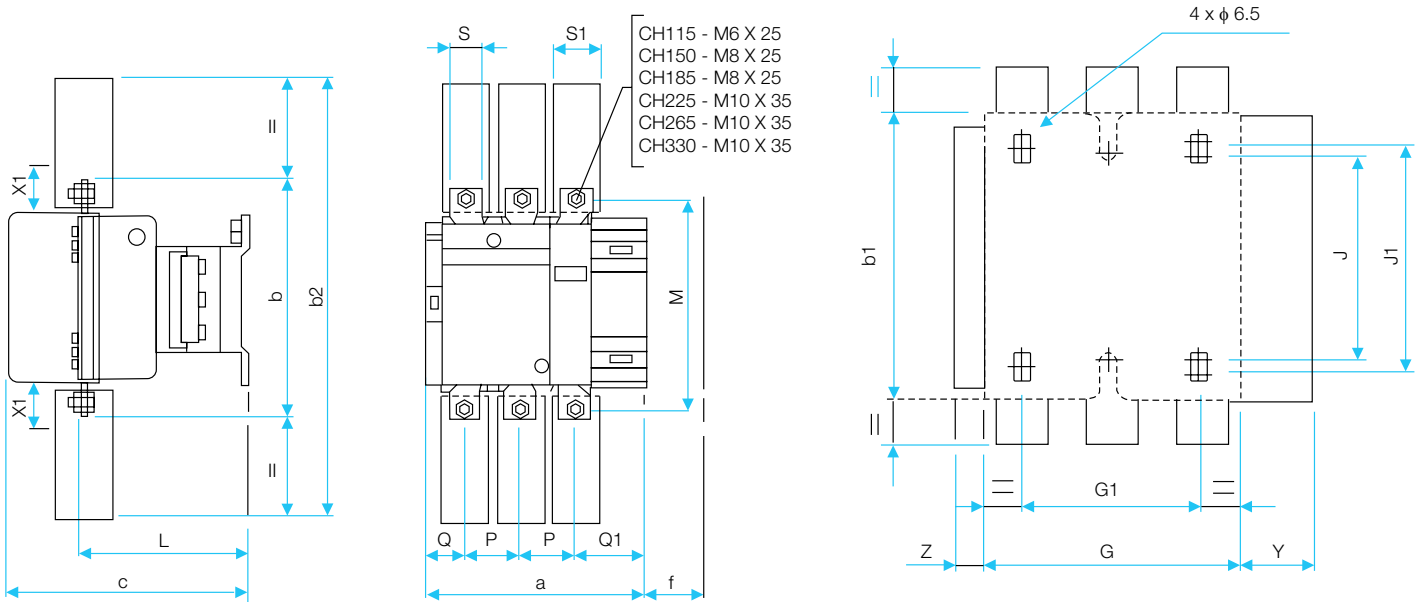

Dimension, in mm

Type No	a	b	b1	b2	c	f	G	G1	J	J1	L	M	P	Q	Q1	S	S1	Y	Z	
CH1 115	3P	164	162	137	265	171	131	106	80	106	120	107	147	37	29.5	60	15	26	44	13.5
	4P	200	162	137	265	171	131	143	80	106	120	107	147	37	29.5	60	15	26	44	13.5
CH1 150	3P	164	170	137	301	171	131	106	80	106	120	107	150	40	26	57.5	20	34	44	13.5
	4P	200	170	137	301	171	131	143	80	106	120	107	150	40	26	55	20	34	44	13.5
CH2 185	3P	168	174	137	305	181	130	111	80	106	120	113.5	154	40	26	59.5	20	34	44	13.5
	4P	208	174	137	305	181	130	151	80	106	120	113.5	154	40	26	59.5	20	34	44	13.5
CH2 225	3P	168	197	137	364	181	130	111	80	106	120	113.5	172	48	21	51.5	25	44.5	44	13.5
	4P	208	197	137	364	181	130	151	80	106	120	113.5	172	48	17	47.5	25	44.5	44	13.5
CH3 265	3P	201	203	145	375	213	147	142	96	106	120	141	178	48	39	66.5	25	44.5	38	21.5
	4P	248	203	145	375	213	147	190	96	106	120	141	178	48	34	66.5	25	44.5	38	21.5
CH4 330	3P	213	206	145	375	219	147	154.5	96	109	120	145	181	48	43	74	25	44.5	45	20.5
	4P	261	206	145	375	219	147	202.5	96	106	120	145	181	48	43	74	25	44.5	38	20.5

f : Minimum distance required for coil removal

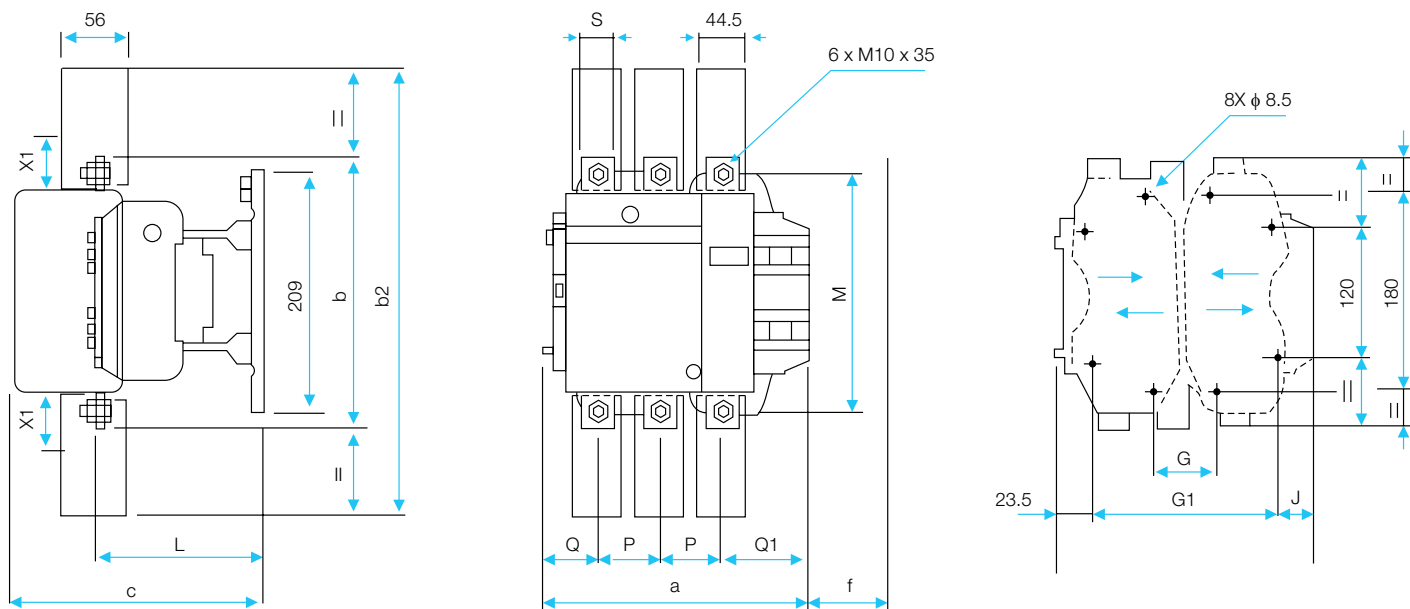
CH5 400 - CH6 500

Dimension, in mm

Type No	a	b	b2	c	f	G*	Gmin	Gmax	G1	G1min	G1max	J	L	M	P	Q	Q1	S	
CH5 400	3P	213	206	375	219	119	80	66	102	170	156	192	19.5	145	181	48	43	74	25
	4P	261	206	375	219	119	80	66	150	170	156	240	67.5	145	181	48	43	74	25
CH6 500	3P	233	238	400	232	141	80	66	120	170	156	210	39.5	146	208	55	46	77	30
	4P	288	238	400	232	141	140	66	175	230	156	265	34.5	150	208	55	46	77	30

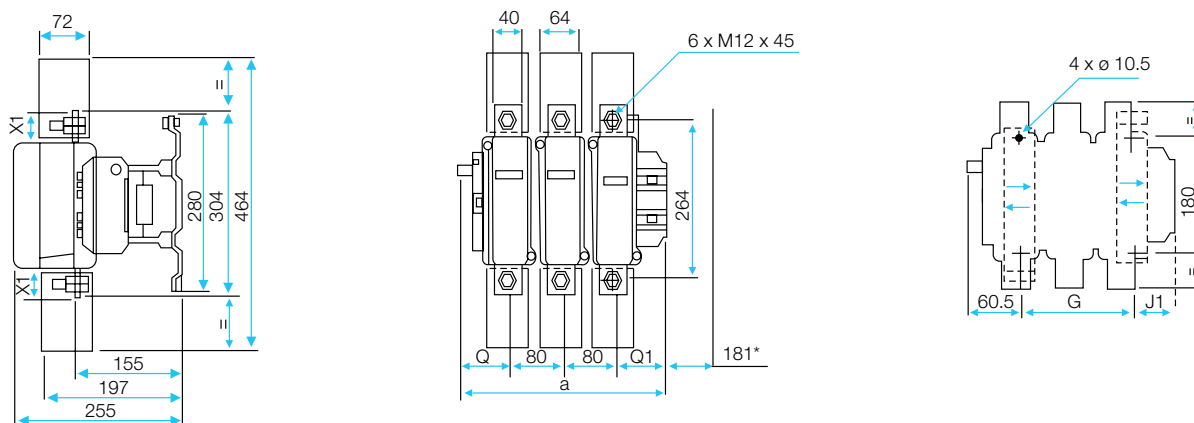
CH7 630

Dimension, in mm

Type No	a	G	Gmin	Gmax	J1	Q	Q1	
CH7 630	3P	309	180	100	195	68.5	60	89
CH7 630	4P	389	240	150	275	68.5	60	89

* Minimum distance required for coil removal

Thermal Overload Relay

Features:

- Protection against overload & single phasing
- Auto manual / manual reset facility
- Ambient temperature compensated
- Potential free trip contacts
- Test mode facility
- Contactor mounting / Individual mounting with adaptor
- Matching to contactor rating upto 95A

A wide range of bimetal thermal overload relays are offered for close protection of motors & other inductive loads against overload & single phasing.



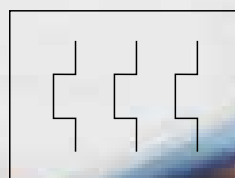

Introduction

A wide range of bimetal thermal overload relays are offered for close protection of motors & other inductive loads against overload, single phasing & unbalanced system voltages.

Thermal Overload Relays are ambient temperature compensated and are independent of variation in ambient temperature. Protection against single phasing & unbalanced voltages has been provided by means of differential tripping mechanism which ensures positive protection of motors / loads. They are provided with 1NO + 1NC potentially free contacts which can be used for signalling. The relay can be used in either Auto or Manual reset mode.

Standards :

IS / IEC : 60947-4-1

Type :

- Auto / manual reset
- Manual reset



Range :

- Contactor Mounting - 0.1A - 93A in 24 direct reading version (Auto / manual).
- Contactor Mounting - 0.1A - 80A in 20 direct reading version (Manual).
- Individual Mounting - 0.1A - 93A in 24 direct reading version (Auto / manual & Manual).
- Electronic Individual Mounting - 30A - 630A in 8 direct reading version (Manual).

Principle of Operation

The heating elements in the main circuit heat the bimetal tripping elements corresponding to the motor load current. The heating elements are calibrated such that the set trip point is achieved in accordance with the standards. By means of trip bar, the movement / deflection of the bimetal is transmitted to plunger which in turn operates the trip mechanism and thus the contacts are separated. The trip point can be easily set on a scale in accordance with the nominal motor rated current.

Bimetal elements for compensating the trip point in case of different ambient temperature is fitted on the trip lever. Buttons are used for testing the circuit to be protected, for resetting by hand and for conversion from manual to auto reset mode.

Differential Mechanism

The relay operates on the differential system of protection provided by the double slide mechanism. Under single phasing and unbalanced voltage conditions, the two slides of the relay undergo differential deflection. One slide senses the movement of the bimetal that deflects the maximum, while the other senses the minimum deflection.

The slides are linked in such a way that the difference in movements of the two slides is amplified for actuation of the trip lever. This leads to accelerated tripping under single phasing.

Thermal Overload Relay

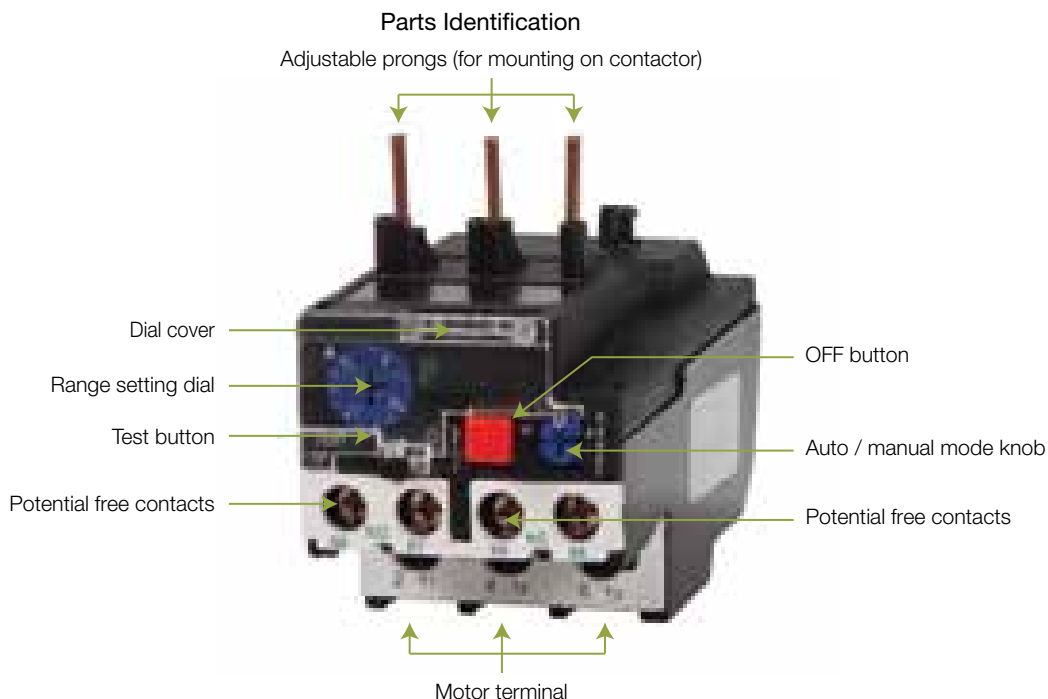

Electronic Overload Relay

The ERT1 4 overload relays are specifically made suitable for operating conditions of motors. They provide protection against

- Thermal overload of three phase or single phase balanced or unbalanced circuits
- Phase failure and large phase unbalance
- Protracted starting times
- Prolonged stalled rotor condition

These electronic overload relays are ambient temperature compensated and based on differential principle & provided with adjustable current setting dial, trip indicator, manual reset & test facility. The current setting can be locked by sealing the transparent protective dial cover.

Parts Identification

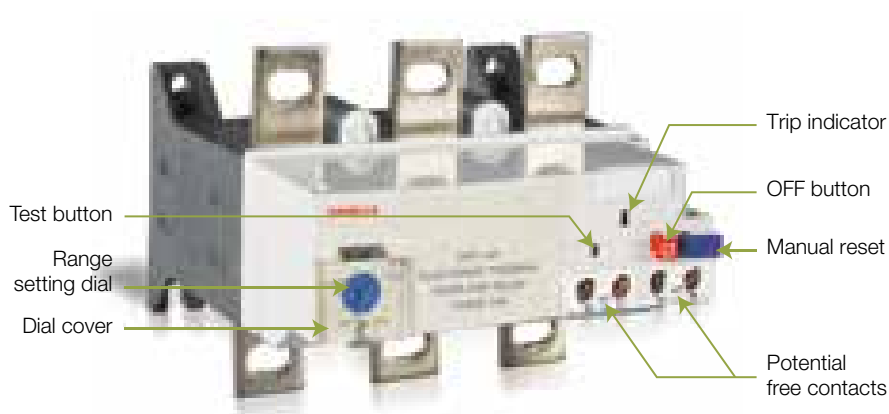

Terminal Marking

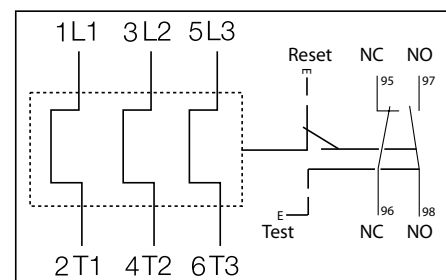

Technical Information

Conformity of Standard	: IS / IEC - 60947 - 4-1
Ambient temperature range	: -5°C - +55°C
Operating Altitude	: 2000 meters
Pollution degree	: 3
Degree of protection	: IP 20
Trip Class	: 10A

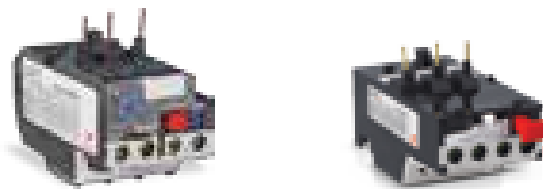

Thermal Overload Relay			
Over Load Relay	Type	Thermal	
Type of Reset		Auto / Manual	Manual
Current Range			
Contactors Mounting	A	0.1 - 93	0.1 - 80
Individual Mounting (with adaptor)	A	0.1 - 93	0.1 - 80
Rated Insulation Voltage (Ui)	V	750	750
Rated Operational Voltage (Ue)	V	415	415
Switching Frequency	OPS. / Hr.	15	15
Terminal Capacity			
Contactors Mounting (RT 21) / (RT 11)	Sq. mm	10	10
Contactors Mounting (RT 22) / (RT 12)	Sq. mm	25	50
Contactors Mounting (RT 23) / (RT 13)	Sq. mm	50	50
Auxilliary Circuit			
Insulation Voltage	V	750	750
Rated Thermal Current	A	6	6
Rated Current (AC-15)	at 220V AC	A	1.64
	at 415 V AC	A	0.95
(DC-13)	at 220 V DC	A	0.15
Auxilliary Terminal	Sq. mm	2 x 2.5	2 x 2.5

Weight / Dimension					
O / L relay auto / manual reset			O / L relay manual reset		
Type	kg	W x H x D	Type	kg	W x H x D
RT21	0.156	47 x 66 x 94	RT11	0.127	45 x 56 x 91
RT22	0.217	59 x 78 x 94	RT12	0.358	63.5 x 73 x 118
RT23	0.433	55 x 83 x 114	RT13	0.364	63.5 x 73 x 118

Technical Information

Conformity of Standard	: IS / IEC - 60947 - 4-1
Ambient temperature range	: -5°C - +55°C
Operating Altitude	: 2000 meters
Pollution degree	: 3
Degree of protection	: IP 20
Trip Class	: 10A

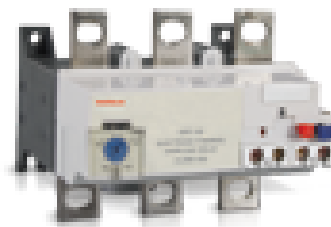

Electronic Overload Relay

Over Load Relay	Type	Electronic
Type of Reset		Manual
Current Range	A	30 - 630
Rated Insulation Voltage (Ui)	V	1000
Rated Operational Voltage (Ue)	V	415
Rated Frequency	Hz	50 / 60
Power Terminal Connection		
Width of Terminal lug	mm	20
Clamping Screw		M8
Tightening torque	Nm	18
Trip Indication		On relay front
Test Function		On relay front
Stop Function		Through stop push button
Tripping limit		
No Trip		1.05 In
Trip		1.2 In
Sensitivity to Single Phasing		Yes
Current Adjustment		Setting dial on relay front
Security Sealing		Yes

Weight / Dimension

Manual reset		
Type	kg	W x H x D
ERT1 4A	0.885	115 x 96 x 123.5
ERT1 4B	0.900	115 x 96 x 123.5
ERT1 4C	0.900	115 x 96 x 123.5
ERT1 4D	0.885	115 x 96 x 123.5
ERT1 5E	0.950	120 x 101 x 123.5
ERT1 6F	2.320	150 x 136.8 x 127.6
ERT1 6G	2.320	150 x 136.8 x 127.6
ERT1 6H	4.160	150 x 136.8 x 127.6

Time / Current Characteristics

Average operating time related to multiples of the tripping current

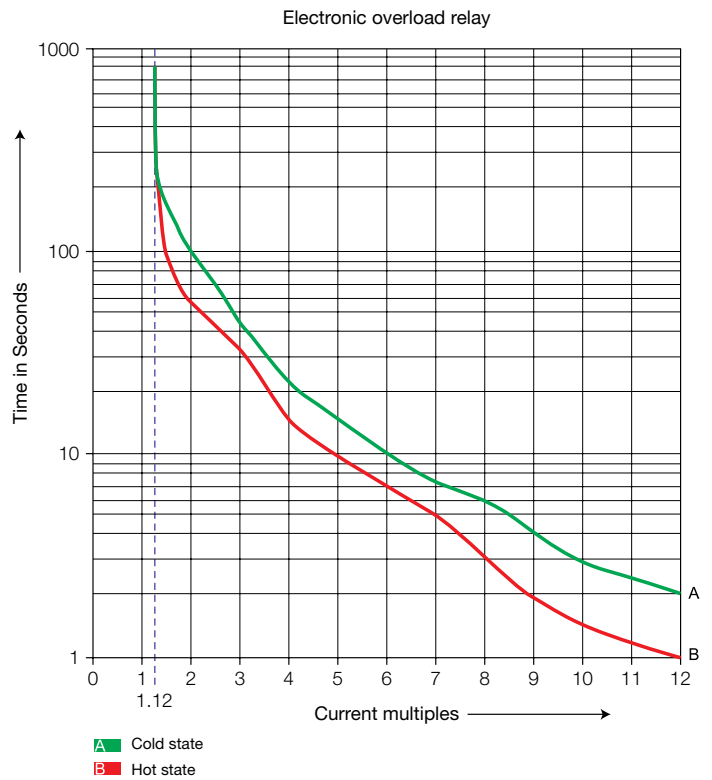
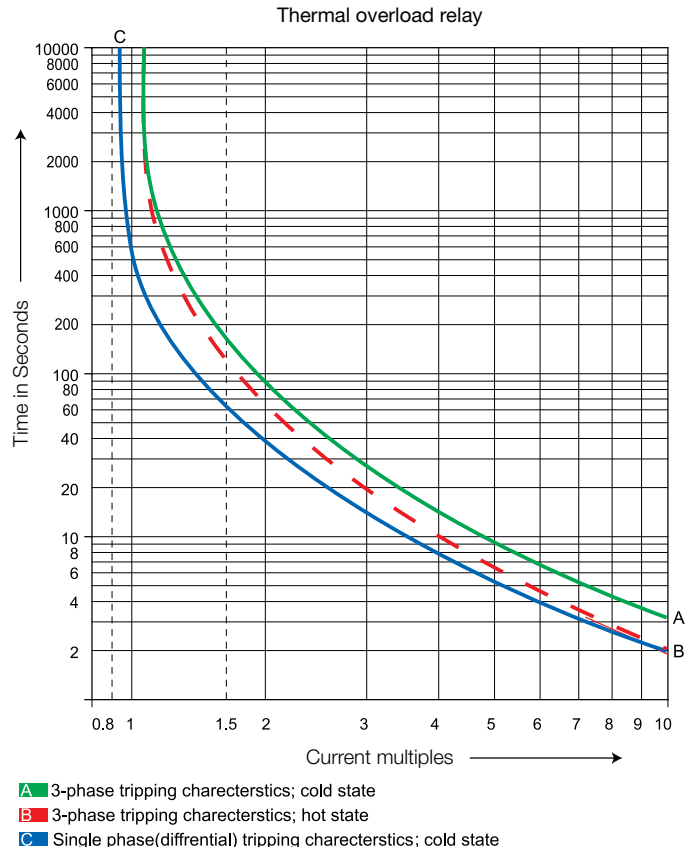

Relay Selection Chart



DOL Starting				
3 ϕ Motor Rating at 415V 50Hz.		Approx. Full Load Current	Relay Range	Backup Fuse Rating
KW	HP	Amp.	Amp.	Amp.
0.37	0.5	1.0	1-1.6	4
0.55	0.75	1.6	1.6-2.5	4
0.75	1	2.0	1.6-2.5	6
1.5	2	3.5	2.5-4	10
2.2	3	5.0	4-6	16
3	4	6.5	5.5-8	20
3.7	5	7.5	7-10	20
5.5	7.5	11.2	10-13	25
7.5	10	14	13-18	25
9	12.5	18	13-18/18-25	32
11	15	21	18-25	50
15	20	28.5	23-32	50
18.5	25	35	30-40	63
22	30	42	38-50	80
30	40	57	48-57/57-66	100
37	50	66	63-80	125
45	60	81	60 - 100	125
55	75	100	90 - 150	160
63	85	112	90 - 150	160
75	100	135	90 - 150	200

Star Delta Starting					
3 ϕ Motor Rating at 415V 50Hz.		Full Load Line current	Full Load phase Current	Relay Range	Backup Fuse Rating
KW	HP	Amp	Amp	Amp	Amp
5.5	7.5	11	6.35	5.5-8	20
7.5	10	14.8	9	7-10	20
9.3	12.5	18	10.39	10-13	25
11	15	21	12.12	10-13	25
15	20	28	16.1	13-18	32
18.5	25	35	20.2	18-25	50
22.5	30	42	24	18-25	50
26	35	47	26.9	23-32	63
30	40	57	33	30-40	80
37	50	66	38.1	30-40	80
45	60	80	47	38-50	100
55	75	100	58	57-66	100
67	90	120	69.2	63-80	160
75	100	135	77.9	48-80	160
90	125	165	95.3	60-100	160
100	135	182	105	90-150	200
110	150	200	115.5	90-150	200

Ordering Information

40

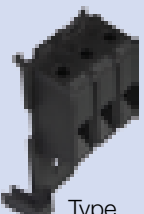
Thermal Over Load Relay (Auto / Manual Reset)					
Relay Frame size	Relay Range	Suitable for Contactor Frame size	Type	Cat. No.	Individual Mounting Block
1	0.1-0.16	CN1 to CN4	RT21A	IHNR11AA	 Type RTA2-25 Cat No. ISSTRX024025
	0.16-0.25		RT21B	IHNR11AB	
	0.25-0.4		RT21C	IHNR11AC	
	0.4-0.63		RT21D	IHNR11AD	
	0.63-1		RT21E	IHNR11AE	
	1-1.6		RT21F	IHNR11AF	
	1.6-2.5		RT21G	IHNR11AG	
	2.5-4		RT21H	IHNR11AH	
	4-6		RT21J	IHNR11AJ	
	5.5-8		RT21K	IHNR11AK	
	7-10		RT21L	IHNR11AL	
	9-13		RT21M	IHNR11AM	
	12-18		RT21N	IHNR11AN	
	17-25		RT21P	IHNR11AP	
2	23-32	CN4	RT22Q	IHNR22AQ	 Type RTA2-36 Cat No. ISSTRX024136
	28-36		RT22R	IHNR22AR	
3	23-32	CN5 to CN6	RT23T	IHNR33AT	 Type RTA2-93 Cat No. ISSTRX024293
	30-40		RT23U	IHNR33AU	
	37-50		RT23V	IHNR33AV	
	48-65		RT23W	IHNR33AW	
	55-70		RT23X	IHNR33AX	
	63-80		RT23Y	IHNR33AY	
	80-93		RT23Z	IHNR33AZ	

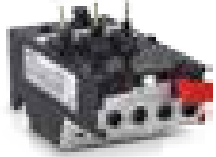
Thermal Over Load Relay (Manual Reset)					
"Relay Frame size"	Relay Range	Suitable for Contactor Frame size	Type	Cat. No	Individual Mounting Block
1	0.1-0.16	CN 1 to CN 4	RT11A	IHNR11MA	 Type RTA1-25 Cat No. ISSTRX024325
	0.16-0.25		RT11B	IHNR11MB	
	0.25-0.4		RT11C	IHNR11MC	
	0.4-0.63		RT11D	IHNR11MD	
	0.63-1		RT11E	IHNR11ME	
	1-1.6		RT11F	IHNR11MF	
	1.6-2.5		RT11G	IHNR11MG	
	2.5-4		RT11H	IHNR11MH	
	4-6		RT11J	IHNR11MJ	
	5.5-8		RT11K	IHNR11MK	
	7-10		RT11L	IHNR11ML	
	10-13		RT11M	IHNR11MM	
	13-18		RT11N	IHNR11MN	
	18-25		RT11P	IHNR11MP	
2	23-32	CN 5 to CN 6	RT12Q	IHNR22MQ	 Type RTA1-80 Cat No. ISSTRX024480
	30-40		RT12R	IHNR22MR	
3	38-50	CN 5 to CN 6	RT13V	IHNR33MV	 
	48-57		RT13W	IHNR33MW	
	57-66		RT13X	IHNR33MX	
	63-80		RT13Y	IHNR33MY	

Electronic Overload Relay (Manual Reset)				
"Relay Frame size"	Relay Range	Suitable for Contactor Frame size	Type	Cat. No
4	30-50	CH 1 to CH 2	ERT1 4A	IHETR050
	48-80		ERT1 4B	IHETR080
	60-100		ERT1 4C	IHETR100
	90-150		ERT1 4D	IHETR150
5	132-220	CH 2 to CH 5	ERT1 5E	IHETR220
6	200-330	CH 2 to CH 7	ERT1 6F	IHETR330
	300-500		ERT1 6G	IHETR500
	380-630		ERT1 6H	IHETR630

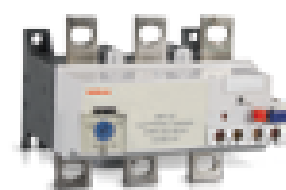

Dimension (in mm)

Thermal Overload Relay (Auto / Manual reset)

RT2 1 25

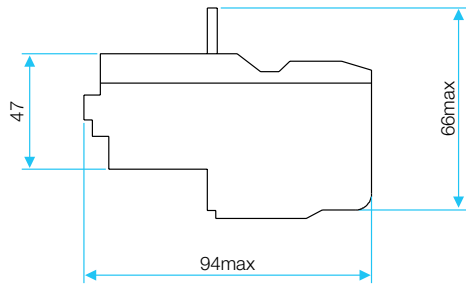

Without adapter block

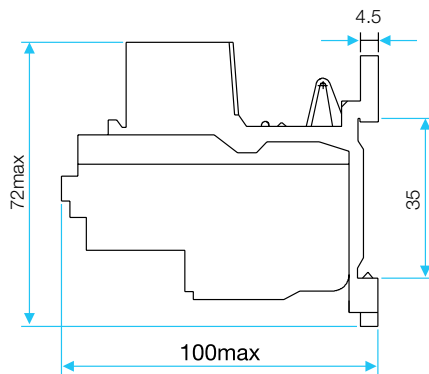
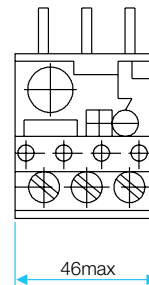

With adapter block

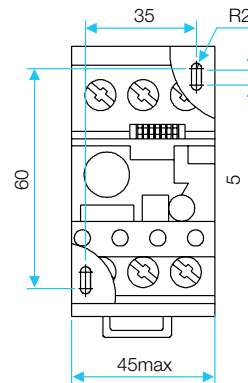

RT2 2 36

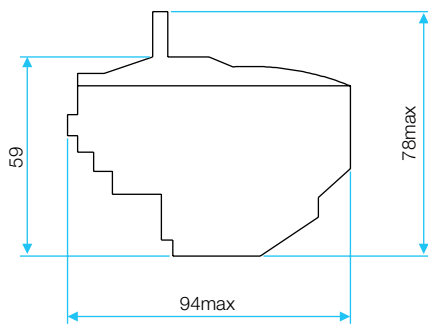

Without adapter block

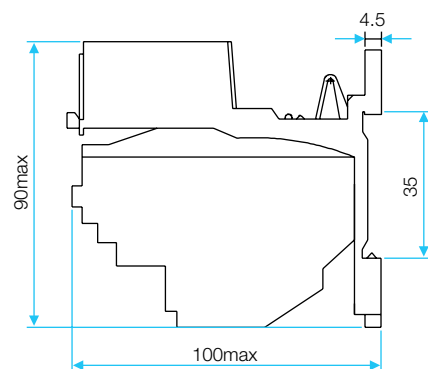
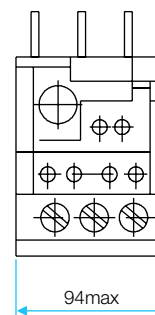

With adapter block

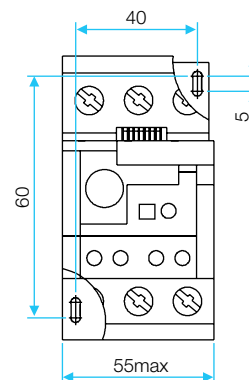

RT2 3 93

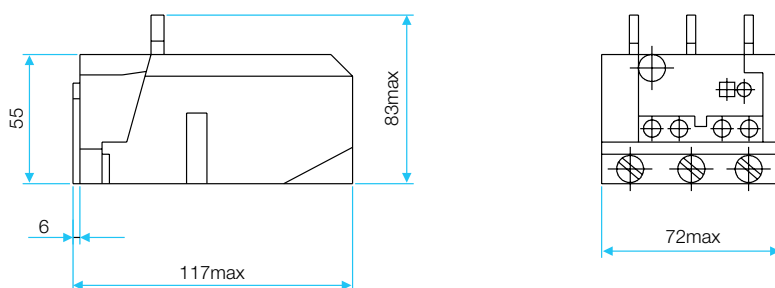

Without adapter block

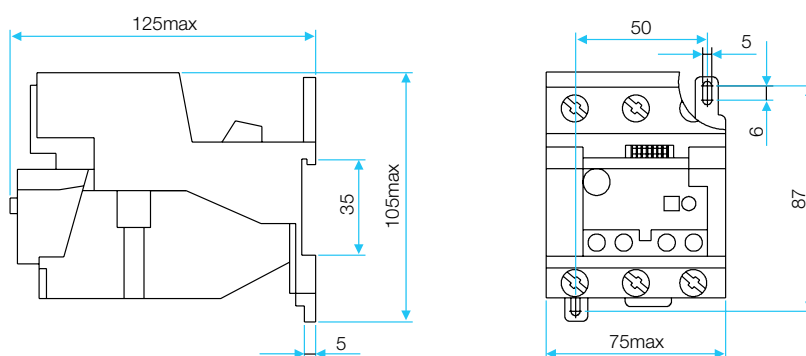

With adapter block

Thermal Overload Relay (Manual Reset)

RT1 1 25

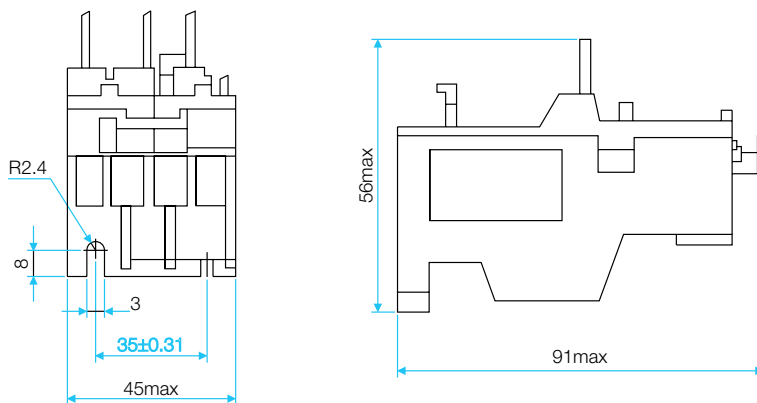

Without adapter block

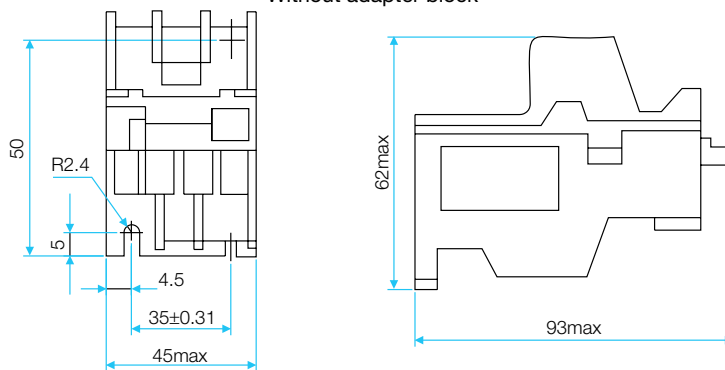

With adapter block

RT1 2 40

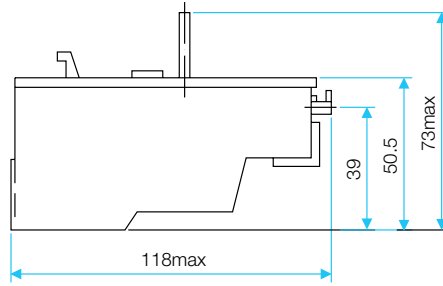
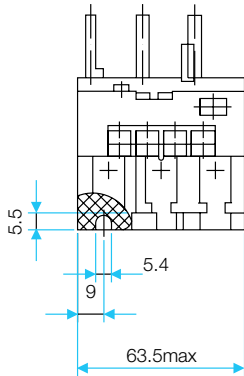

Without adapter block

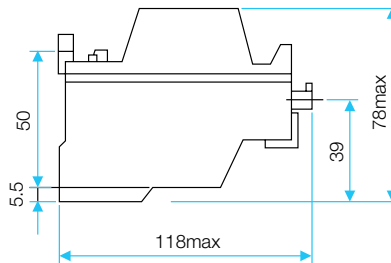
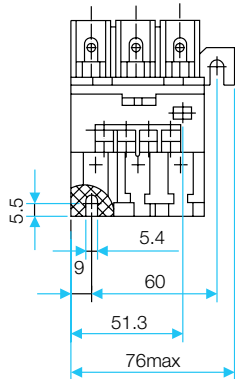

With adapter block

RT1 3 80

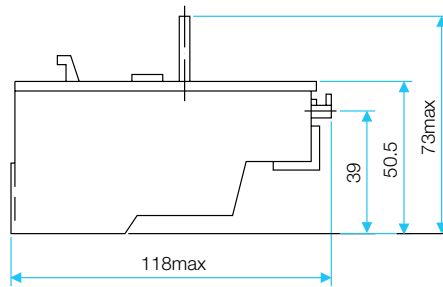
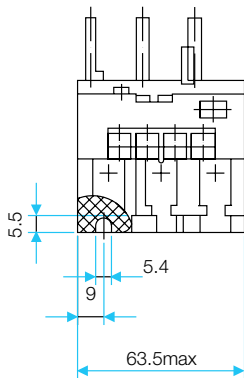

Without adapter block

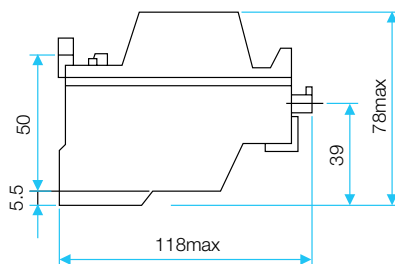
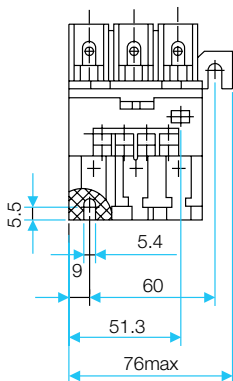

With adapter block

Electronic Overload Relay (Manual reset)

ERT1 4D

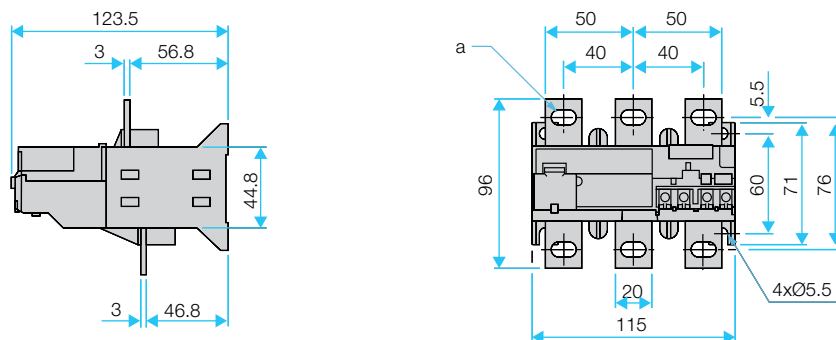

- a 6.5 x 13.5 - ERT1 4A
- 8.5 x 13.5 - ERT1 4B, ERT1 4C, & ERT1 4D

ERT1 5E

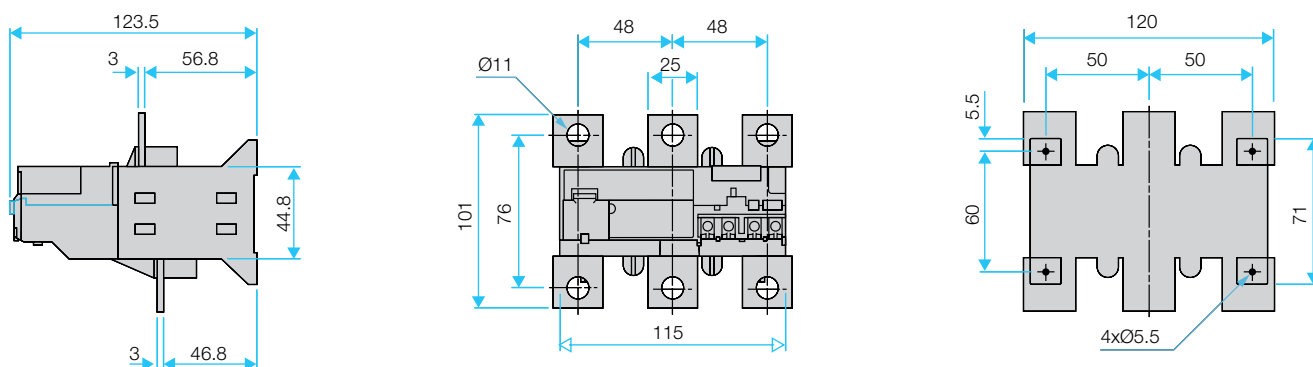

ERT1 6H

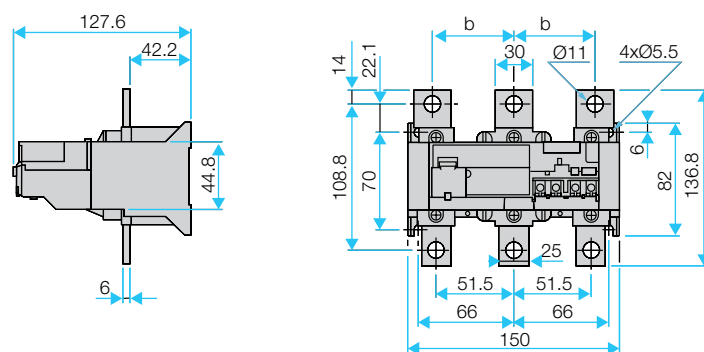

- b 48 - ERT1 6F
- 55 - ERT1 6G, ERT1 6H

Capacitor Duty Contactor

Features:

- High electrical life
- Low watt loss & conservation of energy
- Cost saving & less maintenance
- Safety against high voltage

Normal contactor when used for capacitor switching is unable to meet the operational requirements.

In fact, at the time of switching, a capacitor effectively appears as a short circuit. The magnitude of capacitor in-rush or charging current will depend upon value of AC voltage level alongwith impedance of feeder cables and supply transformers.



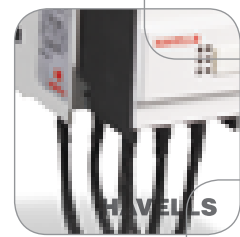
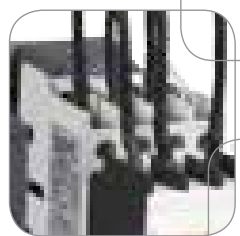
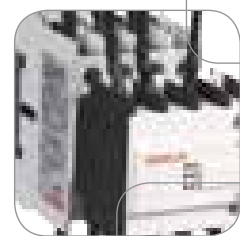
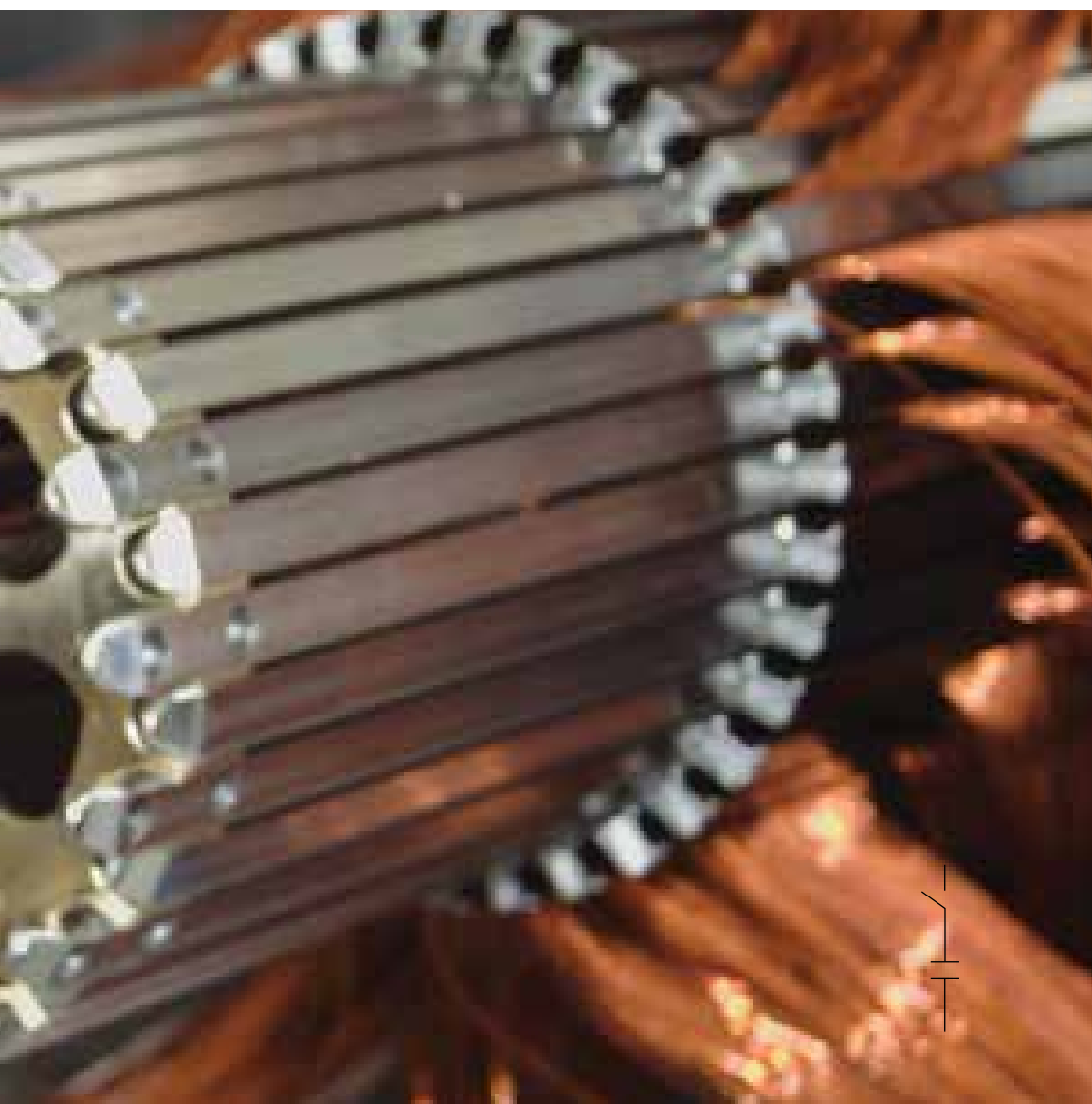

Introduction

Normal contactor when used for capacitor switching is unable to meet the operational requirements.

In fact, at the time of switching, a capacitor effectively appears as a short circuit. The magnitude of capacitor in-rush or charging current will depend upon value of AC voltage level alongwith impedance of feeder cables and supply transformers.

When switching individual capacitor bank the charging current peaks upto 30 times the rated capacitor current can occur and incase of multi stage capacitors the in-rush current peaks of more than 180 times the rated capacitor current can occur.

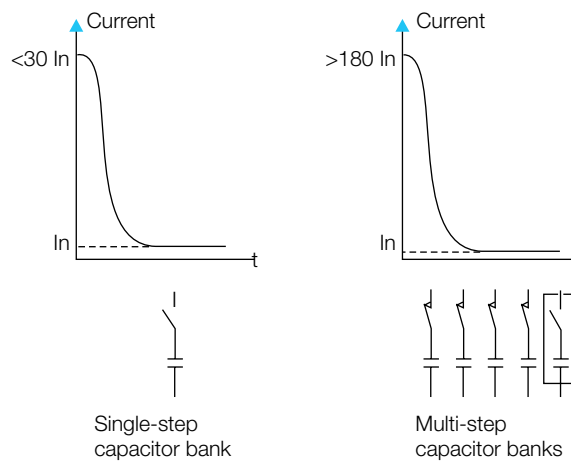

These large current can flow through contactor since initial in-rush current is taken from both main supply and capacitor already connected. Such in-rush current of high magnitude is undesirable & can weld the main contacts of normal contactors.

It is therefore, essential to:

- Limit the current peak by inserting quick discharge series damping resistance.
- Use specific Capacitor Duty Contactors.

Hence, special Capacitor Duty Contactors are designed to meet Capacitor switching application.

Principle of Operation

Contactors are fitted with a block of three early make auxiliary contacts in series with quick discharge damping resistors - 2 per phase to limit peak current to a value within contactor making capacity such that normal rated capacitor current is carried by main contacts which, after closing, effectively short out the resistors.

Standards

IS / IEC : 60947-4-1

Range

12KVAR - 50KVAR in 5 frames

Execution

3 Pole

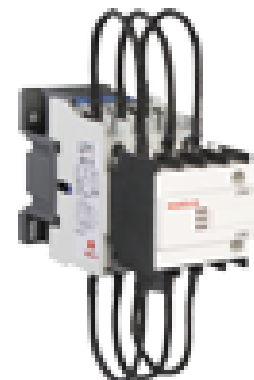

Technical Information

Standard conformity : IS / IEC : 60947-4-1

Utilisation category : AC-6b

Ambient temperature range : -5 °C - + 55 °C

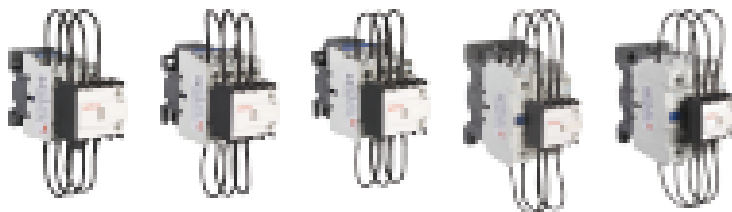

Contactor for capacitor switching							
Contactor	Type	CC2-12	CC3-18	CC4-20	CC5-30	CC6-50	
Rated Current at 415V 50Hz, AC3 - (Ie)	A	18	25	32	65	95	
No. of Poles		3	3	3	3	3	
Rated Insulation Voltage (Ui)	V	750	750	750	750	750	
Rated Operational Voltage (Ue)	V	440	440	440	440	440	
Maximum Switching Capacity (40°C)							
	at 220V/240V	KVAr	6	9	10	15	25
	at 415V/440V		12	18	20	30	50
Mechanical Life	No. of Ops. (Million)	10	10	10	10	10	
Electrical Life at Rated Load	No. of Ops. (Million)	0.2	0.2	0.1	0.1	0.1	
Maximum operating rate	Ops./Hr.	240	240	240	240	100	
Terminal Capacity							
	No. of Cables		1	1	1	1	1
	Flexible / Solid Max. Cable Size	Sq. mm	2.5 / 4	4 / 6	4 / 10	6 / 16	16 / 25
Weight		Kg.	0.610	0.645	0.645	1.3	1.5
Overall Dimension (W x H x D)		mm	56x140x130	58x140x136	58x140x137	75x180x150	85x200x160
Control Circuit (AC coil)							
Operating Voltage Range (50/ 60 Hz)	V	0.7 - 1.1	0.7 - 1.1	0.7 - 1.1	0.7 - 1.1	0.7 - 1.1	
Power Consumption	50Hz - Inrush	VA	110	110	110	200	200
	Sealed	VA	11	11	11	20	20
60Hz - Inrush	VA	115	115	115	200	200	
	Sealed	VA	11	11	11	20	20
Heat dissipation (50/ 60 Hz)	W	3 - 4	6 - 10	6 - 10	6 - 10	6 - 10	
Coil pick up time	ms.	15 - 24	15 - 24	15 - 24	20 - 25	20 - 35	
Coil drop out time	ms.	5 - 20	5 - 20	5 - 20	8 - 15	10 - 20	
Auxilliary Contact							
Rated Thermal Current	A	10	10	10	10	10	
Rated Insulation Voltage	V	750	750	750	750	750	
Terminal Capacity	No. of Cables		1	1	1	1	1
	Max. Size	Sq. mm	1.5	1.5	1.5	1.5	1.5

Ordering Information

50

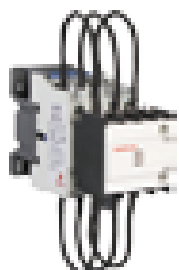

KVAR Rating at 50/60Hz $\theta \leq 55^\circ \text{C}$	Inst. Aux. Contact		Type	Cat. No.
	NO	NC		
415/440V				
12	1	0	CC2 1210*	IHPAE012210*
18	1	0	CC3 1810*	IHPAE018310*
20	1	0	CC4 2010*	IHPAE020410*
30	1	1	CC5 3011*	IHPAE030511*
50	1	1	CC6 5011*	IHPAE050611*

* To Complete Cat. No. Suffix Voltage Code From Coil Voltage Table

Note : 1. For additional aux. contacts block (side mounted type) can be mounted if required. Refer accessories table.



Spare Coils (AC)		
For use of Capacitor Duty Contactor type	Type	Cat. No.
CC2 12	CX1-2*	ISPNCN2*
CC3 18 & CC4 20	CX1-4*	ISPNCN4*
CC5 30 & CC6 40	CX1-6*	ISPNCN6*

*To complete the type/ cat no. suffix the coil voltage from the coil voltage table

AC Coils								
Code*	A	C	E	G	H	J	K	N
AC Voltage	24V	48V	110V	220V	240V	380V	415V	550V

Dimension (in mm)

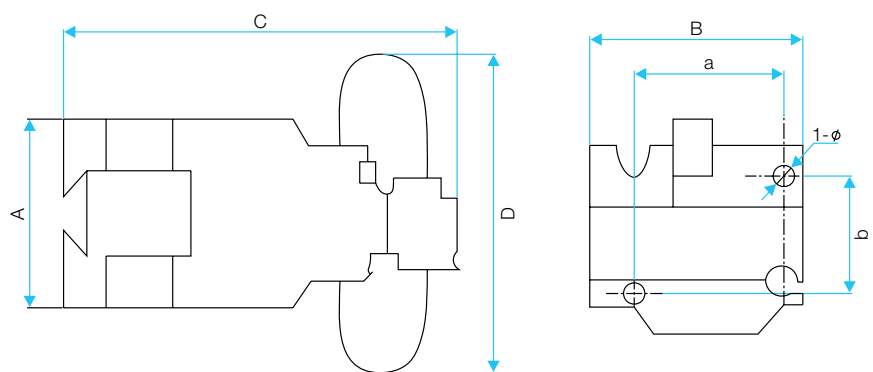

Dimension, in mm								
Type	External dimension				Mounting dimension			
	A	B	C	D	a	b	Ø	Din Rail
CC2 12	84	56	130	140	40	50 / 60	4.5	35mm
CC3 18	87	58	136	140	40	50 / 60		
CC4 20	87	58	137	140	40	50 / 60		
CC5 30	127	75	150	180	40	100 / 110	6.5	35mm or 75mm
CC6 50	127	85	160	200	40	100 / 110		

Motor Protection Circuit Breaker

Features:

- Havells MB2 series motor protection circuit breaker effectively combines control & protection lending greater efficiency & flexibility through various functions, accessories & compact design
- Compact size & space saving
- Close overload & short circuit protection
- High breaking capacity
- Sensitive to single phasing
- Visual fault indication
- Simple & easy installation
- Wide range of accessories
- Available in open execution / in plastic enclosure

Havells presents the versatile MB2 series motor protection circuit breakers specifically designed for control and protection of motors, conforming to IS / IEC 60947-2 & IS / IEC 60947-4-1 standards.

Motor Circuit Breakers are advanced three pole thermal-magnetic circuit breakers offering excellent short circuit protection by magnetic non adjustable tripping elements under 3ms, this results in rapid build up of an arc voltage which limits the current of the short circuit to a very low level.

In fact, this current limiting capability of MB2 motor breakers provides high short circuit breaking capacity upto 100 kA. The thermal elements coupled with automatic ambient temperature compensation over a range of -20 °C to +60 °C provide close / accurate overload protection qualifying it as a trip class 10 device.

The breaker comes with a wide range of add-on accessories to meet variety of application needs in motor circuits and system automation.



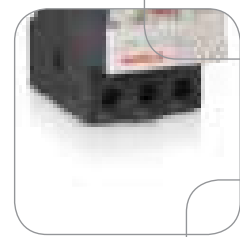
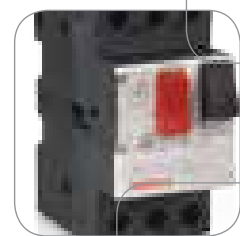

Operation

Motor Circuit Breakers control is manual and local when it is used on its own. However when it is used in conjunction with a contactor, the control is automatic and remote.

The ON / OFF actuation is by push button. Switching ON is controlled manually by operating the start button marked 'I' and switching OFF by operating the stop button marked 'O' or automatically by the thermal magnetic protection elements or by a voltage trip add on accessory namely: Shunt trip / Under Voltage Trip (UVT).

Protection

Motor protection is provided by the thermal-magnetic protection elements incorporated in the motor circuit-breaker.

The magnetic elements (short-circuit protection) have a non-adjustable tripping threshold, fixed at 13 times the maximum setting current of the thermal trips.

The thermal elements (overload protection) include automatic compensation for ambient temperature variations.

The rated operational current of the motor is displayed by means of a graduated / calibrated knob. All live parts are protected against direct finger contact from the front panel. Personal protection is also provided.

The undervoltage trip allows the circuit-breaker to de-energize in the event of an undervoltage condition. The user is therefore protected against sudden starting of the machine when normal voltage is restored, since the Start button 'I' has to be pressed to restart the motor.

The shunt trip provides remote tripping of the circuit-breaker. These circuit breakers are suitable for isolation. The start button can be padlocked in stop position in open execution unit.

Connection

The MPCBs are designed for connection by screw clamp terminals.

Mounting

These motor circuit-breakers can be mounted by screw fixing or clip on mounting on symmetrical, asymmetrical or combination Din-rail.

Parts Identification

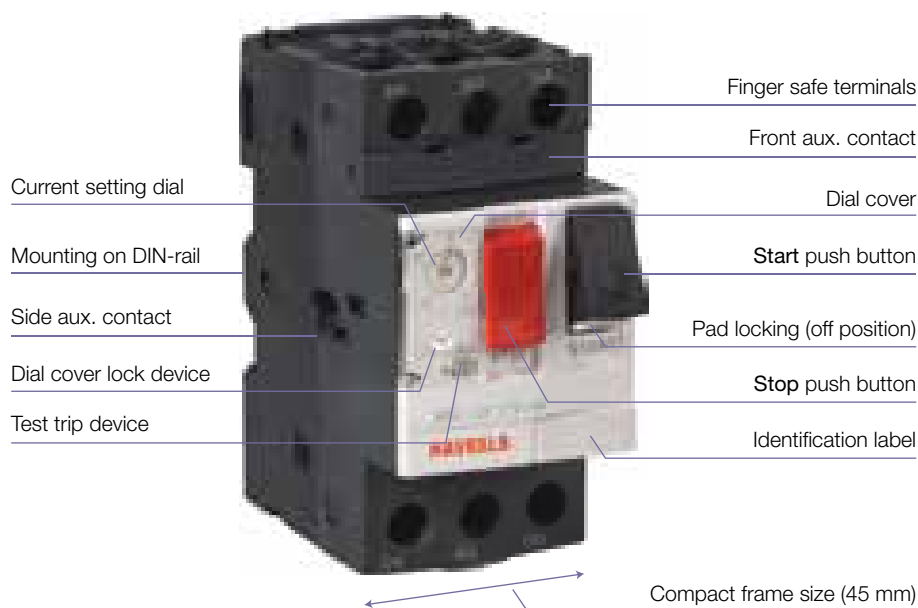

Technical Information		
Parameters	Type	MB-2
Standard conformity		IS / IEC 60947-2 & IS / IEC 60947-4-1
Utilization category		A (Circuit breaker) / AC-3 (Motor duty)
Rated thermal current range (Ith)	A	0.16-32
Rated operational voltage	V	690
Rated insulation voltage	V	690
Rated operational frequency	Hz	50 / 60
Rated impulse with stand voltage	kV	6
Breaking capacity (Icu)		
upto 4kW / 5.5-9kW / 15kW	kA	100 / 15 / 10
Breaking capacity (Ics % of Icu)		
upto 4kW / 5.5-7.5kW / 9kW / 11kW	%	100 / 50 / 40 / 50
Power dissipated per pole	W	2.5
Mechanical life (C.O.)	No.of ops.	0.1 million
Duty class (Max. operating rate)	C.O. / hr	25
Rated duty		Continuous
Degree of protection open / enclosed		IP-20 / IP-65
Shock resistance		30 gn-11ms
Vibration resistance		5 gn
Ambient temperature range	°C	-20 to +60
Max. operating altitude	m	2000
Suitable for isolation		Yes
Phase failure sensitivity		Yes
Operating position		90° on either side off normal vertical mounting plane
Terminal capacity		
Solid cable (Max.)	Sq. mm	2 x 6
Flexible cable (Max.)	Sq. mm	2 x 6
Tightening torque	N.m.	1.7
Weight	Kg.	0.260
Dimension	mm	44.5 x 89 x 67.2



Technical Information				
Add on Accessory	Type	Aux. Contact		Fault Signalling Contact
		Side mounted	Front mounted	Side mounted
Contact configuration		(1NO + 1NC) / 2NO	(1NO + 1NC) / 2NO	1NO / 1NC
Rated insulation voltage (Ui)	V	690	690	690
Rated thermal current (Ith)	A	6	2.5	2.5
Utilisation Category		AC 15	AC 15	AC 14
Rated operation voltage (Ue)	V	110 / 240 / 415	110 / 240	110 / 240
Rated current	A	4.5 / 3.3 / 2.2	1 / 0.5	0.5 / 0.3
Mechanical life (Close - open)	Ops.	1,00,000	1,00,000	1,000
Number of cables / Conductor		2	2	2
Cable size (max.)	Sq. mm	2.5	2.5	2.5



Technical Information			
Add on Accessory	Type	Under Voltage Trip (UVT)	Shunt Trip (ST)
		Side mounted	Side mounted
Rated insulation voltage (Ui)	V	690	690
Operation current	V	0.85 - 1.1 Un	0.7 - 1.1 Un
Drop out voltage	V	0.7 - 0.35 Un	0.75 - 0.2 Un
Power consumption (inrush)	VA	12	14
Power consumption	W	8	10.5
Power consumption (sealed)	VA	3.5	5
Power consumption	W	1.1	1.6
Operating time	ms	10 - 15	10 -15
Number of cables / Conductor		1 / 2	1 / 2
Cable size (Max.)	Sq. mm.	2.5	2.5
Tightening torque	Nm	1.4	1.4
Mechanical life (Close - open)	Ops.	1,00,000	1,00,000

Motor Kw Rating & Current Setting Range						
3-phase motor rating AC-3 duty 415 V , 50Hz				Thermal Current Setting range	Magnetic tripping current	Type
kW	HP	Icu (kA)	Ics (%)	A	A	
0.02	-	100	100	0.1 - 0.16	1.5	MB2 - 01
0.06	-	100	100	0.16 - 0.25	2.4	MB2 - 02
0.09	-	100	100	0.25 - 0.40	5	MB2 - 03
0.12	-	100	100	0.40 - 0.63	8	MB2 - 04
0.18	-					
0.25	0.33	100	100	0.63 - 1	13	MB2 - 05
0.37	0.5	100	100	1 - 1.6	22.5	MB2 - 06
0.55	0.75					
0.75	1	100	100	1.6 - 2.5	33.5	MB2 - 07
1.1	1.5	100	100	2.5 - 4	51	MB2 - 08
1.5	2.01					
2.2	3	100	100	4 - 6.3	78	MB2 - 10
3	4.02	100	100	6 - 10	138	MB2 - 14
4	5.3					
5.5	7.5	15	50	9 - 14	170	MB2 - 16
7.5	10	15	50	13 - 18	223	MB2 - 20
9	12.5	15	40	17 - 23	327	MB2 - 21
11	17.5	15	40	20 - 25	327	MB2 - 22
15	20	10	50	24 - 32	416	MB2 - 32



Dimension (in mm)

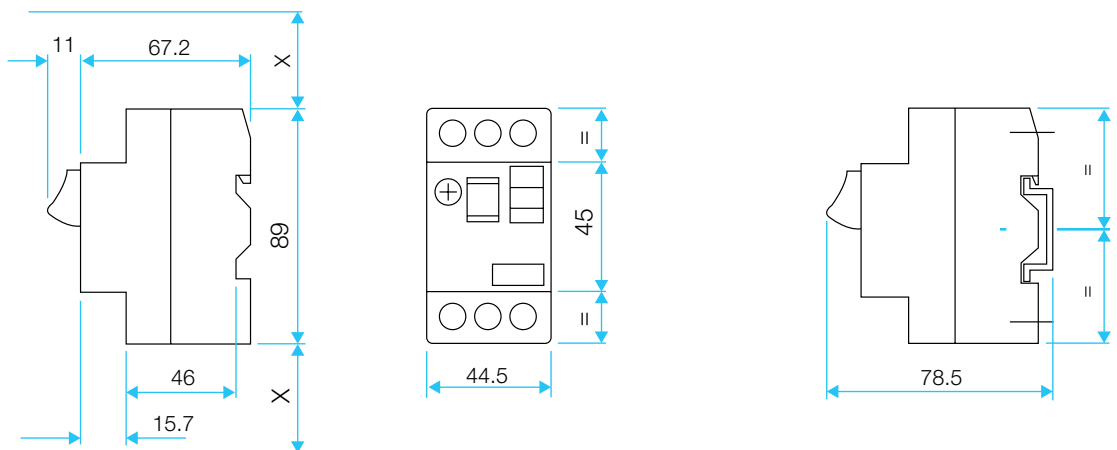

X - Electrical clearance = 40 mm

Time-Current Characteristics

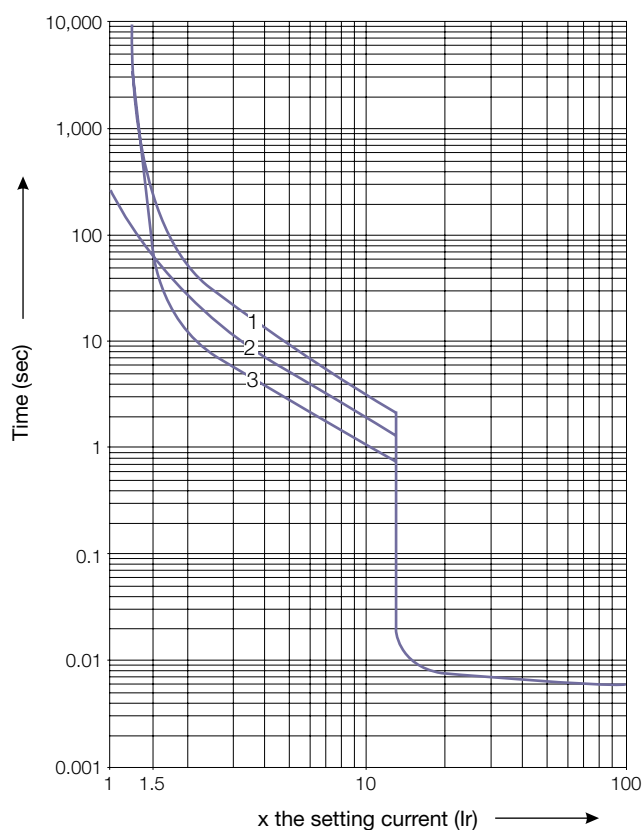

- 1) 3 poles from cold state
- 2) 2 poles from cold state
- 3) 3 poles from hot state

Let Through Energy (I^2t) Characteristics

Thermal limit on short circuit (in magnetic operating zone)

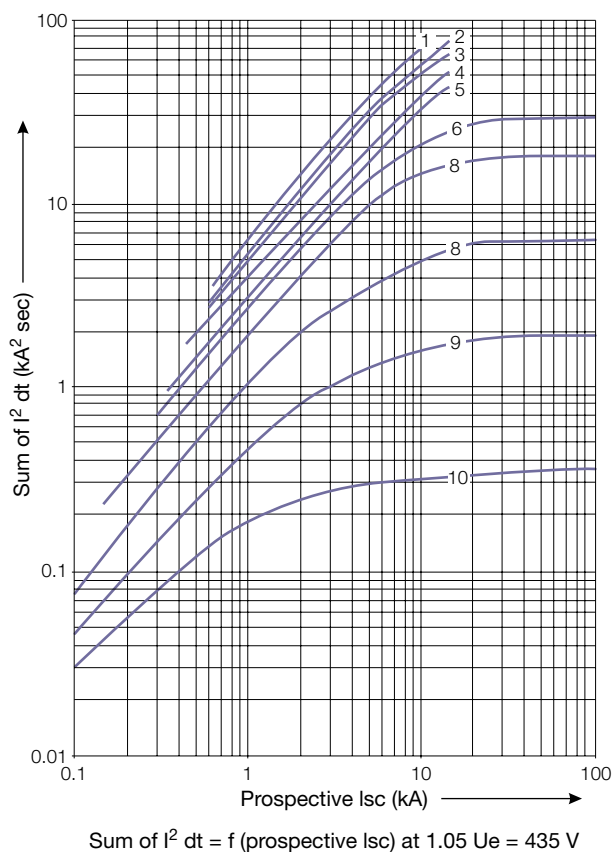

- (1) 24 - 32 A
- (2) 20 - 25 A
- (3) 17 - 23 A
- (4) 13 - 18 A
- (5) 9 - 14 A
- (6) 6 - 10 A
- (7) 4 - 6.3 A
- (8) 2.5 - 4 A
- (9) 1.6 - 2.5 A
- (10) 1 - 1.6 A

Sum of $I^2 dt = f(\text{prospective Isc})$ at $1.05 U_e = 435 V$

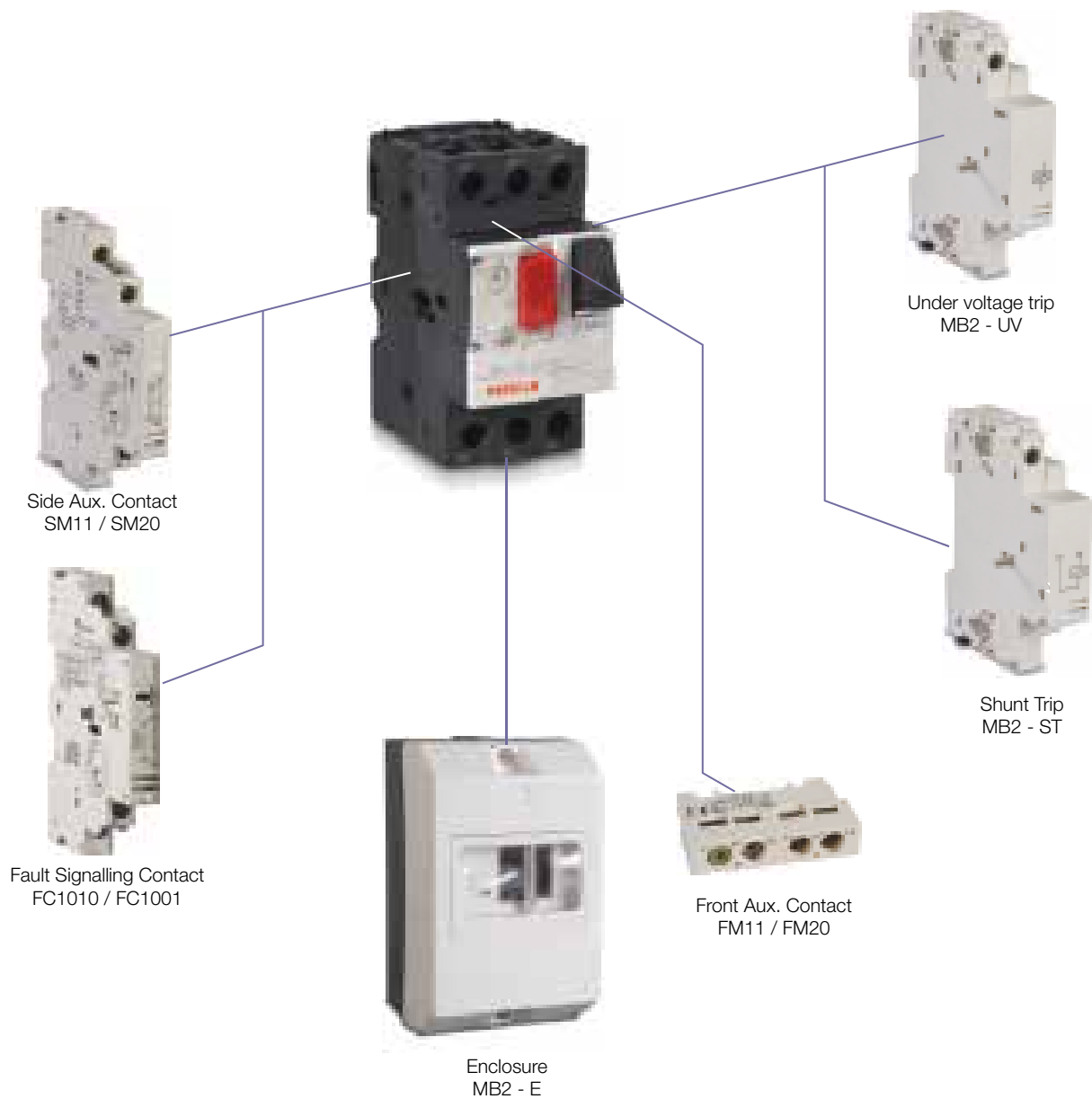

CIRCUIT DIAGRAMS

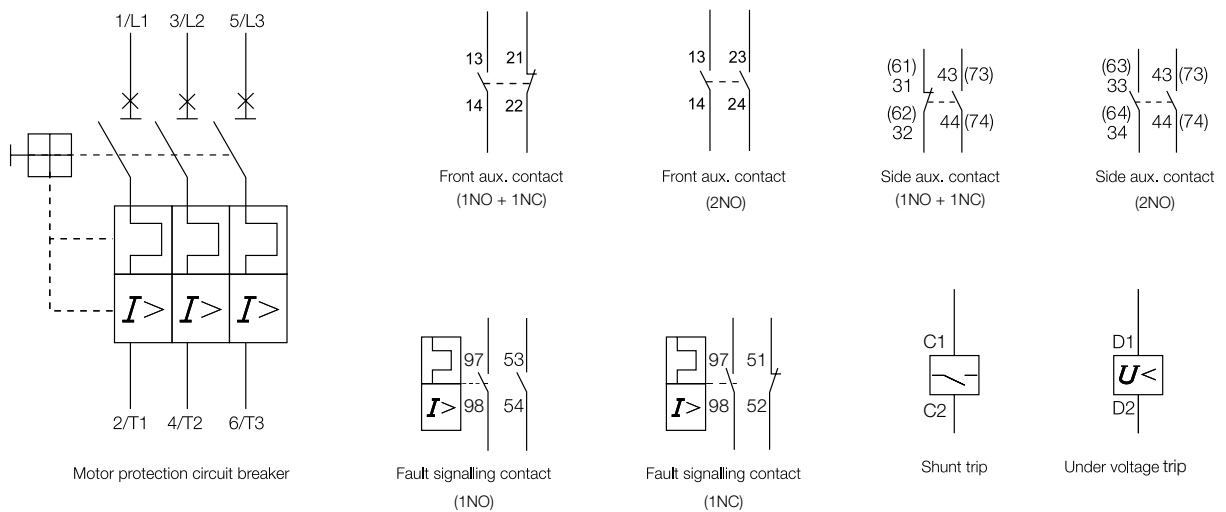

Ordering Information

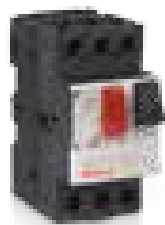

Relay Range	Type	Cat. No.
0.1-0.16	MB2 - 01	IHPMPBA0A0
0.16-0.25	MB2 - 02	IHPMPBB0B0
0.25-0.4	MB2 - 03	IHPMPBC0C0
0.4-0.63	MB2 - 04	IHPMPBD0D0
0.63 - 1	MB2 - 05	IHPMPBE0E0
1-1.6	MB2 - 06	IHPMPBF0F0
1.6-2.5	MB2 - 07	IHPMPBG0G0
2.5 - 4	MB2 - 08	IHPMPBH0H0
4 - 6.3	MB2 - 10	IHPMPBJ0J0
6 - 10	MB2- 14	IHPMPBK0K0
9 - 14	MB2 - 16	IHPMPBL0L0
13 - 18	MB2- 20	IHPMPBM0M0
17 - 23	MB2 - 21	IHPMPBN0N0
20 - 25	MB2 - 22	IHPMPBQ0Q0
24 - 32	MB2 - 32	IHPMPBP0P0

Note: MB2 - 22 provide on request

Add on Accessories



Accessory	Type	Cat. No.
Side aux. contact (1NO+1NC)	MB2 - SM11	ISPMASM011
Side aux. contact (2 NO)	MB2 - SM20	ISPMASM020
Front aux. contact (1NO+1NC)	MB2 - FM11	ISPMAFM011
Front aux. contact (2NO)	MB2 - FM20	ISPMAFM020
Fault signalling contact (1NO)	MB2 - FC1010	ISPF0010
Fault signalling contact (1NC)	MB2 - FC1001	ISPF0001
Shunt trip 110 V 220 V 380 V / 415 V	MB2 - ST1 MB2 - ST2 MB2 - ST3	ISPST110 ISPST220 ISPST415
Under voltage trip 110 V 220 V 380 V / 415 V	MB2 - UV1 MB2 - UV2 MB2 - UV3	ISPUV110 ISPUV220 ISPUV415
MPCB Enclosure (IP 65)	MB2 - E	ISSPEX0063

Cosmic Motor Starter

Features:

- Liberal enclosure: Ample wiring space is available for easy termination.
- Degree of Protection: IP54 enclosure makes it suitable for use in almost all climatic conditions.
- Ease of Maintenance: Contactor & Overload Relay mounted on base plate, easily removable for maintenance if required.
- User friendly: Contactor Coil & Contact housing can be replaced with ease.

Range :

- Direct on line starters 0.75HP - 100HP in four frame sizes
- Automatic Star Delta Starters 10HP - 150HP in three frame sizes
- Reversing Starters 2HP - 20HP in single frame size
- Direct On Line Submersible Pump Starter 5HP - 15HP
- Automatic Star Delta Submersible Pump Starter 5HP - 45HP

Specification :

Conforms to IS / IEC: 60947-4-1

Motor Starter is meant for starting / stopping a motor and protects against overload & single phasing condition. It consists of Contactor, Thermal Overload Relay, ON / OFF Push buttons housed in a sheet steel enclosure.



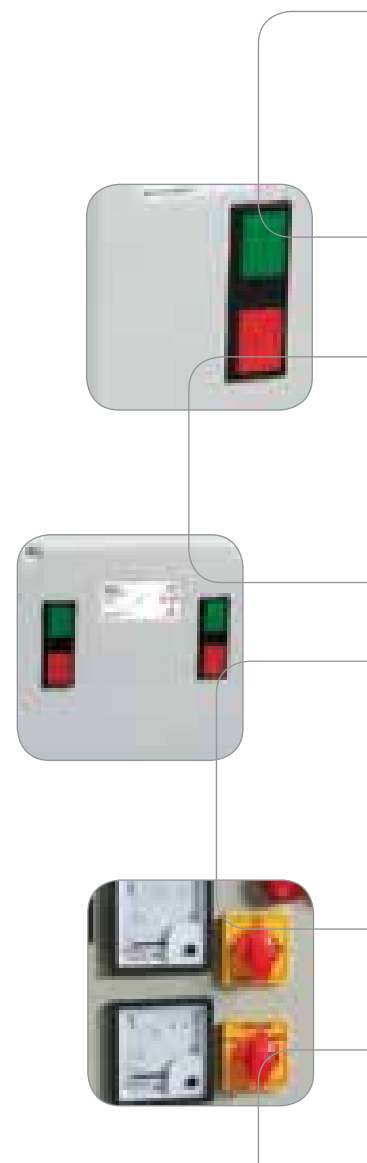
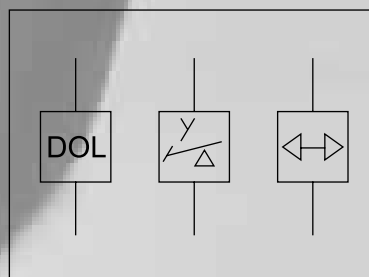

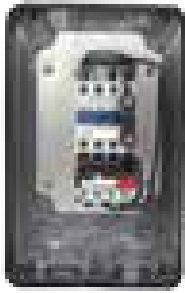

Dol Starter - upto 100 HP

A DOL starter consists of contactor, overload relay, ON/OFF push buttons, housed in a sheet steel enclosure.

DOL Starters are available in different ratings & sizes. The starter provides ample space for wiring. Overload Relays are mounted on the Contactor which further results in increased availability of space.

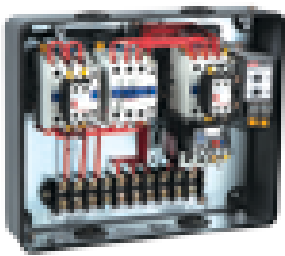

Automatic Star Delta Starter - upto 150 HP

These Starters are provided with a Star Contactor, a Delta Contactor & a main Contactor with Overload Relay, ON/OFF push buttons and an electronic timer for changeover from Star to Delta. When the ON push button is pressed, the Star and the main Contactor are switched ON and the motor runs in Star position. After the preset time, the changeover to Delta takes place by switching off the Star Contactor and Delta Contactor is switched ON, the motor now runs in Delta position.

Star Delta Starters help in reducing the starting currents. The motor during starting draws only one third of the normal starting current. After the motor has achieved a speed of 80 - 85% of synchronous speed, it switches over to Delta position.

The changeover from Star to Delta is achieved by means of an electronic timer which is adjustable from 1 - 12 seconds or 3 - 30 seconds depending on specific requirements. The timer is independent of ambient temperature and therefore provides precise changeover time.

Star Delta Starters of higher ratings can also be offered against specific requirements.

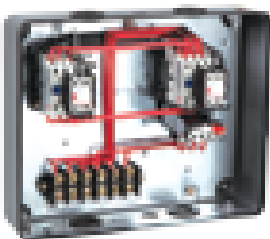

Reversing Starter - upto 20 HP

These Starters are used to run motor initially in one direction and then in the opposite direction. This is achieved by providing two contactors one for forward direction & the other for reverse direction. Mechanical / Electrical interlocks are provided in these Starters so that under no circumstance the operation will result in short circuit.



Havells Submersible Starters are designed to meet the stringent requirements of both agricultural as well as domestic applications. The basic function of starter is isolation, motor control, protection against short circuit, overload & single phasing. Havell's starters address the customer needs to the fullest by incorporating the latest technology in switching & protection accompanied with the best after sales service and an unparalleled distribution network across India.

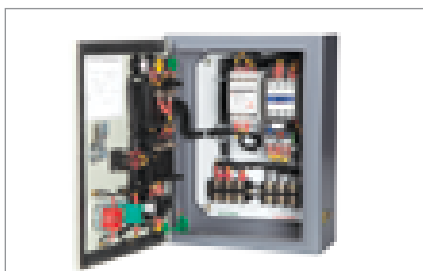

Direct On Line Submersible Pump Starter upto 15HP

A DOL starter consists of contactor, overload relay, ON/OFF push buttons, housed in a sheet steel enclosure. It is meant for starting/stopping a motor and protects the motor against overload and single phasing condition.

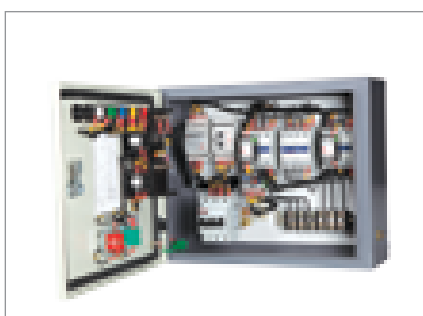

Automatic Star Delta Submersible Pump Starter upto 45HP

In the beginning the star & main contactors get switched ON and the pump runs in star position. After the preset star time, the auto changeover to delta takes place and thereafter the starter runs in delta position. Star delta starters help in meeting the starting current requirement during the star operation and the running current requirement during the delta operation of the submersible pump motor. The changeover from star to delta is achieved by means of an electronic timer which can be adjusted from 1 to 30 seconds as per the requirement of the motor. The **Standard Model**, offers protection against overload and single phasing, the **Deluxe Model** offers additional protection against short circuit besides overload and single phasing.

Features

- **Reliability:** Thermal bimetallic relay provides protection against overload, and single phasing Preventor gives protection against Single Phasing.
- **Selectivity:** Wide band operating Voltage 260V-415V AC (for use of Agricultural segment).
- **Robust Construction:** Heavy Duty Contactor capable of working under severe conditions.
- **Easy to Check:** Manual Trip Facility is provided to check the trip operation.
- **Flexible Design:** Flexibility of onsite conversion between Automatic / Manual reset.
- **Better Safety for motor and Operator:** Provision of MCB gives better protection against short circuit on ASD Premium Model.
- **Repeat accuracy:** Electronic Timer is provided to precisely control the changeover from Star to Delta. The changeover time can be set accurately from 1 to 30 seconds as per the motor requirement.
- **Added Safety from Flash-Over:** A pause time has been provided between Star to Delta changeover to allow proper quenching of arc. The pause timing is available from 30 to 150ms.
- **Option for Extended Protection:** In case of momentary interruption in power supply the water in the pipes flowing backwards into the ground. Sudden restoration of power supply during this period causes excessive load and may even result into burning of the motor. To prevent this, starters can be made available with the option of protection of a built-in on-delay in the SPP unit. Further, this delay can be provided optional as one minute or five minutes.
- **Three Mode Operation:** Starter is provided with three modes of operation through a door mounted selector switch.
 - a. 'Auto' mode with single-phasing preventor in circuit starts automatically.
 - b. In 'Manual' mode the starter needs to be initialized manually through start button.
 - c. **SPP Bypass** In this SPP (including all protection provided therein) is bypassed. In this mode, the only protection available is against overloading provided by overload relay.

Note: The on-delay in Single Phasing Preventor unit comes into effect only in auto mode.

Technical Information

Reference Standard	:	IS / IEC 60947-4-1
Type	:	Air Break
Rated Operational Voltage	:	415V AC
Rated Frequency	:	50Hz
Utilization Category	:	AC3
Degree of Protection	:	IP 54
Mounting	:	Wall / Surface
Cable entry	:	Top & Bottom
Earth Connection	:	Diagonal (Top & Bottom)
Enclosure material	:	CRCA Sheet Steel
Type of Overload Relay	:	Thermal Bimetallic
Relay reset	:	Auto-Manual / Manual

Direct Online Starters (DOL)

Selection Chart

Motor Rating 415V, 3-Phase, 50Hz		Full Load Line Current	Contactor		Overload Relay		Backup Fuse	Recommended Cable Size Sq. mm.	
HP	kW	A	Type	Rating (A)	Type	Range (A)	Rating (A)	Al.	Cu.
0.75	0.6	1.1	CN1 12	12	RT11F	1-1.6	4	1.5	1
1	0.7	1.4	CN1 12	12	RT11G	1.6-2.5	6	1.5	1
2	1.5	2.9	CN1 12	12	RT11H	2.5-4.0	10	1.5	1
3	2.2	4.3	CN1 12	12	RT11J	4.0-6.0	16	1.5	1
5	3.7	7.2	CN1 12	12	RT11L	7.0-10	20	1.5	1
7.5	5.6	10.8	CN2 18	18	RT11M	10-13	25	2.5	1.5
10	7.5	14.4	CN2 18	18	RT11N	13-18	25	2.5	2.5
15	11.2	21.5	CN4 32	32	RT11P	18-25	50	6	4
20	14.9	28.7	CN4 32	32	RT22Q	23-32	50	10	6
25	18.7	35.9	CN5 40	40	RT13V	30-40	63	16	10
30	22.4	43.1	CN5 50	50	RT13W	38-50	80	16	10
40	29.8	57.4	CN5 65	65	RT13Y	57-66	100	25	16
50	37.3	71.8	CN6 80	80	RT23Z	63-80	125	35	25
60	44.8	86.2	CH6 95	95	ERT1 4D	80-93	125	50	35
75	56	107.7	CH1 115	115	ERT1 4D	90-150	160	50	35
85	63.4	122.1	CH1 150	150	ERT1 4D	90-150	160	70	50
100	74.6	143.6	CH1 150	150	ERT1 5E	132-220	200	70	50

Automatic Star Delta Starters (ASD)

Selection Chart

Motor 415 V	Rating at 50Hz, 3φ	Full Load Line Current	Full Load Phase Current	Contactor		O/L Relay (with SPP)	Backup HBC Fuse Rating	Recommended Cable Size			
				Type	Rating			Supply Side (mm ²)		Motor Side (mm ²)	
HP	KW	Amp.	Amp.		Amp.	Amp.	Amp.	Al.	Cu.	Al.	Cu.
10.0	7.5	14.0	8.08	CN2 18	18	9-13	20	2.5	2.5	1.5	1.5
12.5	9.3	18.0	10.39	CN2 18	18	12-18	25	4	2.5	1.5	1.5
15.0	11.2	21.0	12.12	CN3 25	25	12-18	25	6	4	2.5	2.5
20.0	14.9	28.0	16.1	CN3 25	25	17-25	32	10	6	4	2.5
25.0	18.7	35.0	20.2	CN4 32	32	17-25	50	16	10	6	4
30.0	22.4	40.0	23.0	CN4 32	32	23-32	50	16	10	6	4
35.0	26.1	47.0	26.90	CN4 32	32	28-36	63	25	16	10	6
50.0	37.3	66.0	38.1	CN5 50	50	37-50	80	35	25	16	10
60.0	44.8	80.0	46.2	CN5 50	50	48-65	100	50	35	16	10
75.0	56.0	100.0	57.7	CN5 65	65	55-70	100	50	35	25	16
90.0	67.1	120.0	69.2	CN6 80	80	63-80	160	70	50	35	25
100.0	74.6	135.0	77.9	CN6 95	95	80-93	160	70	50	35	25
125.0	93.3	165.0	95.3	CH1 115	115	90-150	160	150	95	50	35
150.0	111.9	200.0	115.5	CH1 150	150	90-150	200	150	95	70	50

Provision of Devices in Submersible Pump Starter			
Items	DOL	Standard ASD	Premium ASD
Single Phasing Preventor	✓	✓	✓
Star Delta Timer	✗	✓	✓
Auto / Manual Switch	✓	✓	✓
Amp. Meter	✓	✓	✓
Volt. Meter	✓	✓	✓
On / Off Push Button	✓	✓	✓
MCB	✗	✗	✓
Light Indicator	2	5	5
Volt. Meter Selector Switch	✓	✓	✓

Direct On Line Submersible Pump Starter

Selection Chart							
Motor rating 415 V, 3-Phase 50Hz		Full Load Current (A)	Max. Operational Current (A)	Contactor Rating (A)	Overload Relay Range (A)	Recommended Cable Size	
						Supply / Motor Side (Sq. mm)	
HP	kW					Al	Cu
1	0.75	1.4	2.5	18	1.6-2.5	1.5	1
2	1.5	2.9	4.5	18	2.5-4	1.5	1
3	2.2	4.3	6.5	18	5.5-8	1.5	1
5	3.7	7.5	10.1	18	9-13	1.5	1
7.5	5.5	11	15.2	18	12-18	2.5	1.5
10	7.5	14	20.2	25	17-25	2.5	2.5
12.5	9.3	18	25.3	32	17-25	6	4
15	11	21.5	30.4	32	23-32	6	4

Automatic Star Delta Submersible Pump Starter											
Motor rating 415 V, 3-Phase 50Hz		Full Load Current (A)	Max. Operational Current (A)	Phase Current (A)	Contactor Rating (A)	Overload Relay Range (A)	MCB Rating (A)	(Recommended Cable Size)			
								Supply Side (Sq. mm)		Motor Side (Sq. mm)	
HP	kW							Al	Cu	Al	Cu
5	3.7	7.5	10.13	5.85	18	5.5-8	25	1.5	1.5	1.5	1.0
7.5	5.5	11.25	15.19	8.77	18	7-10	25	2.5	2.5	1.5	1.5
10	7.5	15	20.25	11.69	18	9-13	25	2.5	2.5	1.5	1.5
12.5	9.3	18.75	25.31	14.61	18	12-18	32	4	2.5	1.5	1.5
15	11	22.5	30.38	17.54	25	17-25	32	6	4	2.5	2.5
17.5	13.1	26.25	35.44	20.46	32	17-25	40	10	6	4	2.5
20	15	30	40.5	23.38	32	17-25	50	10	6	4	2.5
22.5	16.8	33.75	45.56	26.31	32	23-32	63	16	10	6	4
25	19	37.5	50.63	29.23	32	23-32	63	16	10	6	4
27.5	20.5	41.25	55.69	32.15	40	30-40	100	16	10	6	4
30	22.4	45	60.75	35.08	50	30-40	100	16	10	6	4
35	26	52.5	70.88	40.92	50	37-50	100	25	16	10	6
40	30	60	81	46.77	65	37-50	100	35	25	16	10
45	33.6	67.5	91.13	52.61	80	48-65	125	35	25	16	10

Ordering Information



Direct On Line Starter

Direct On-Line Starters						
Motor Rating 415V, 3-Phase, 50Hz		Contactor		Overload Relay		Motor Starter
HP	kW	Type	Rating (A)	Type	Range (A)	Cat. No.
0.75	0.6	CN1 12	12	RT11F	1-1.6	IHPDOLFA*
1	0.7	CN1 12	12	RT11G	1.6-2.5	IHPDOLGA*
2	1.5	CN1 12	12	RT11H	2.5-4	IHPDOLHA*
3	2.2	CN1 12	12	RT11J	4-6	IHPDOLJA*
5	3.7	CN1 12	12	RT11L	7-10	IHPDOLLA*
7.5	5.6	CN2 18	18	RT11M	10-13	IHPDOLMB*
10	7.5	CN2 18	18	RT11N	13-18	IHPDOLNB*
15	11.2	CN4 32	32	RT11P	18-25	IHPDOLPD*
20	14.9	CN4 32	32	RT22Q	23-32	IHPDOLQD*
25	18.7	CN5 40	40	RT12R	30-40	IHPDOLVE*
30	22.4	CN5 50	50	RT13V	38-50	IHPDOLWE*
40	29.8	CN5 65	65	RT13X	57-66	IHPDOLYF*
50	37.3	CN6 80	80	RT13Y	63-80	IHPDOLZF*
60	44.8	CN6 95	95	RT23Z	80-93	IHPDOLDG*
75	56	CH1 115	115	ERT1 4D	90-150	IHPDOLDG*A
85	63.4	CH1 150	150	ERT1 4D	90-150	IHPDOLDG*B
100	74.6	CH1 150	150	ERT1 5E	132-220	IHPDOLEH*



Automatic Star Delta Starter

Fully Automatic Star Delta Starters (ASD)						
Motor Rating 415V, 3-Phase, 50Hz		Contactor		Overload Relay		Motor Starter
HP	kW	Type	Rating (A)	Type	Range (A)	Cat. No.
10	7.5	CN2 18	18	RT21M	9-13	IHPASDMB*
12.5	9.3	CN2 18	18	RT21N	12-18	IHPASDNB*
15	11	CN3 25	25	RT21N	12-18	IHPASDNC*
20	15	CN3 25	25	RT21P	17-25	IHPASDPD*
25	19	CN4 32	32	RT21P	17-25	IHPASDQD*
30	22.5	CN4 32	32	RT22Q	23-32	IHPASDQD*A
35	26	CN4 32	32	RT22R	28-36	IHPASDUE*
50	37	CN5 50	50	RT23V	37-50	IHPASDWE*
60	45	CN5 50	50	RT23W	48-65	IHPASDWF*
75	55	CN5 65	65	RT23X	55-70	IHPASDYF*
90	67.5	CN6 80	80	RT23Y	63-80	IHPASDCG*
100	75	CN6 95	95	RT23Z	80-93	IHPASDDG*
125	90	CH1 115	115	ERT1 4D	90-150	IHPASDDG*A
150	110	CH1 150	150	ERT1 4D	90-150	IHPASDEH*

* To complete Cat No., suffix voltage code from coil voltage table.



Reversing Starter

Reversing Starters						
Motor Rating 415V, 3-Phase, 50Hz		Contactor		Overload Relay		Motor Starter
HP	kW	Type	Rating (A)	Type	Range (A)	Cat. No.
2	1.5	CN1 12	18	RT11H	2.5-4	IHPREVHB*
3	2.2	CN1 12	18	RT11J	4-6	IHPREVJB*
5	3.7	CN1 12	18	RT11L	7-10	IHPREVLB*
7.5	5.6	CN2 18	18	RT11M	10-13	IHPREVMB*
10	7.5	CN2 18	18	RT11N	13-18	IHPREVNB*
15	11.2	CN4 32	32	RT11P	18-25	IHPREVPD*
20	14.9	CN4 32	32	RT22R	28-36	IHPREVRD*

* To complete Cat No., suffix voltage code from coil voltage table.

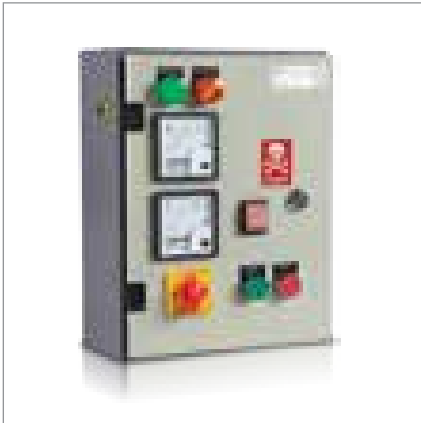

Direct On Line Submersible Pump Starter

Direct On Line Submersible Pump Starter				
HP	kW	Contactor Rating (A)	Overload Relay Range (A)	Cat. No.
5	3.7	18	9-13	IHSDOAMBW
7.5	5.5	18	12-18	IHSDOANBW
10	7.5	25	17-25	IHSDOAPCW
12.5	9.3	32	17-25	IHSDOAPDW
15	11	32	23-32	IHSDOAQDW



Automatic Star Delta Submersible Pump Starter (Standard)

Automatic Star Delta Submersible Pump Starter (Standard)				
HP	kW	Contactor Rating (A)	Overload Relay Range (A)	Cat. No.
5	3.7	18	5.5-8	IHSASAKBW
7.5	5.5	18	7-10	IHSASALBW
10	7.5	18	09-13	IHSASAMBW
12.5	9.3	18	12-18	IHSASANBW
15	11	25	17-25	IHSASAPCW
17.5	13.1	32	17-25	IHSASAPDW
20	15	32	17-25	IHSASAPDWA
22.5	16.8	32	23-32	IHSASAQDW
25	19	32	23-32	IHSASAQDWA
27.5	20.5	40	30-40	IHSASAUJEW
30	22.4	50	30-40	IHSASAUJWA
35	26.1	50	37-50	IHSASAVEW
40	29.8	65	37-50	IHSASAVEWA
45	33.6	80	48-65	IHSASAWFW



Automatic Star Delta Submersible Pump Starter (Deluxe)

Automatic Star Delta Submersible Pump Starter (Deluxe)					
HP	kW	Contactor Rating (A)	Overload Relay Range (A)	TP MCB Rating (A)	Cat. No.
5	3.7	18	5.5-8	25	IHDASAKBW
7.5	5.5	18	7-10	25	IHDASALBW
10	7.5	18	09-13	25	IHDASAMBW
12.5	9.3	18	12-18	32	IHDASANBW
15	11	25	17-25	32	IHDASAPCW
17.5	13.1	32	17-25	40	IHDASAPDW
20	15	32	17-25	50	IHDASAPDWA
22.5	16.8	32	23-32	63	IHDASAQDW
25	19	32	23-32	63	IHDASAQDWA
27.5	20.5	40	30-40	100	IHDASAUJEW
30	22.4	50	30-40	100	IHDASAUJWA
35	26.1	50	37-50	100	IHDASAVEW
40	29.8	65	37-50	100	IHDASAVEWA
45	33.6	80	48-65	125	IHDASAWFW

Dimensions (in mm)

DOL Starter 0.75HP - 20HP
Frame Size: 1 & 2

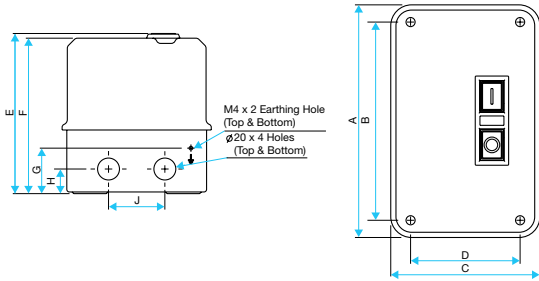

Frame Size	HP Rating	A	B	C	D	E	F	G	H	J
1	0.75 to 5	185	135	105	60	139	135	43	25	30
2	7.5 to 20	223	190	143	105	154	149	44	24	54

DOL Starter 25HP - 60HP
Frame Size: 3

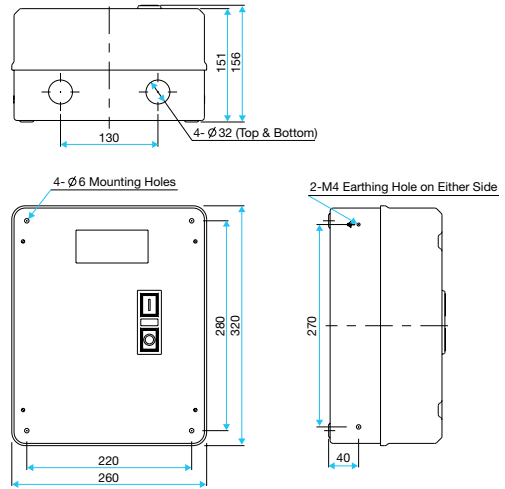

DOL Motor Starter 75HP - 100HP
Frame Size: 4

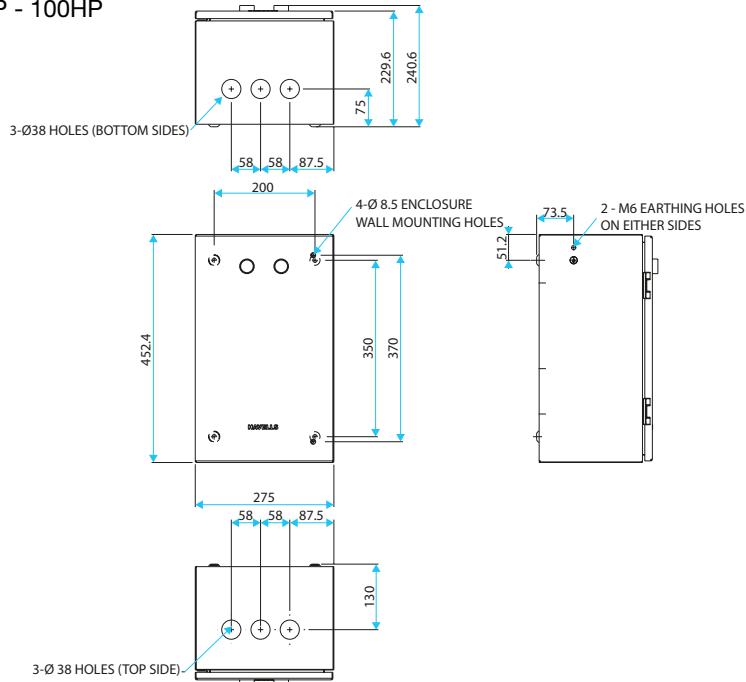

Circuit Diagram for DOL Motor Starter

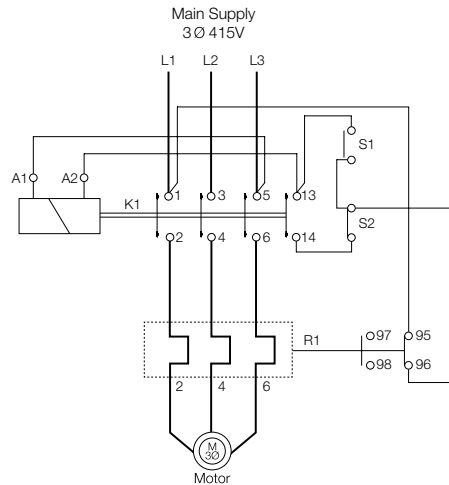

- K1 = Contactor
- R1 = Overload Relay
- S1 = Start Push Button
- S2 = Stop/Reset Push Button

Connection shown for 415V, 50Hz Coil

For 220V, 50Hz coil connect neutral to A1 of K1 contactor and remove the link between L3 to A1

Dimensions (in mm)

Reversing Starter 2HP - 20HP

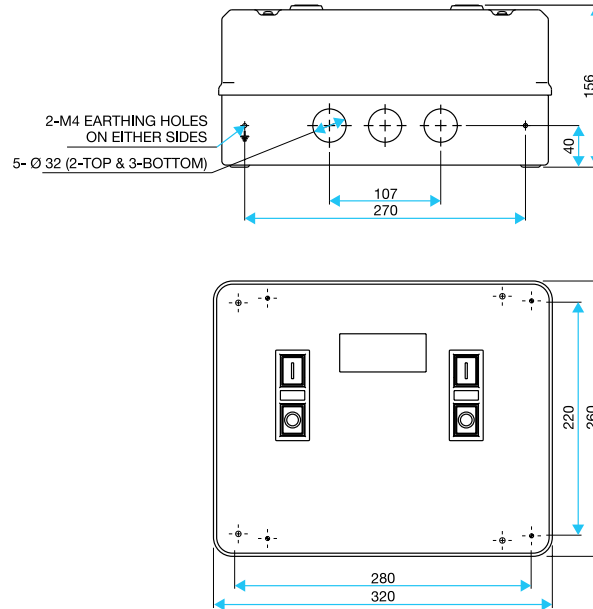

Circuit Diagram for Reversing Starater

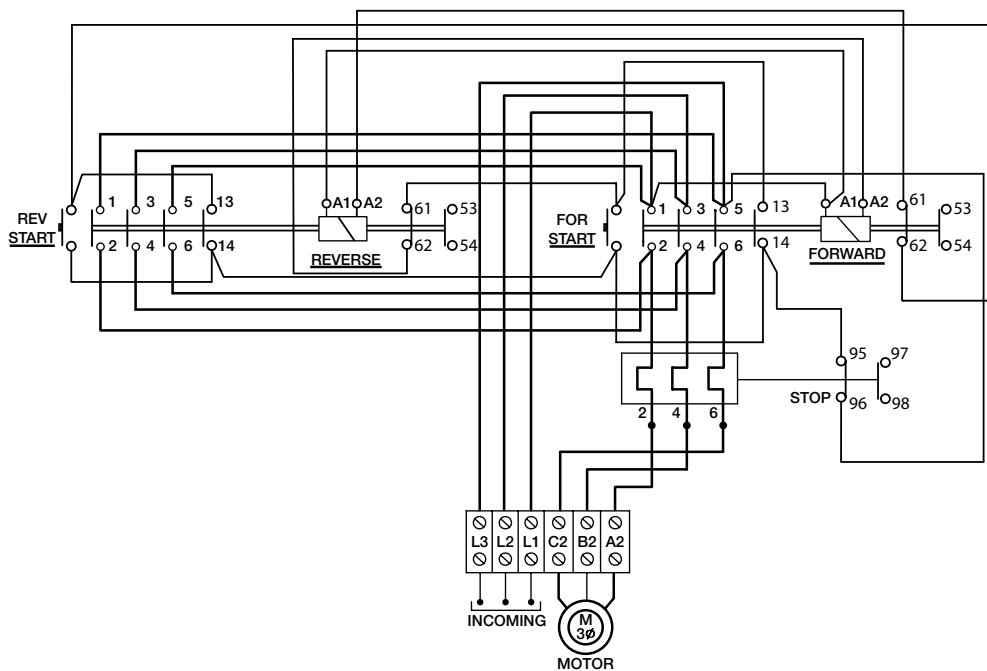

Dimensions (in mm)

ASD Motor Starter 10HP - 35HP
Frame Size: 1

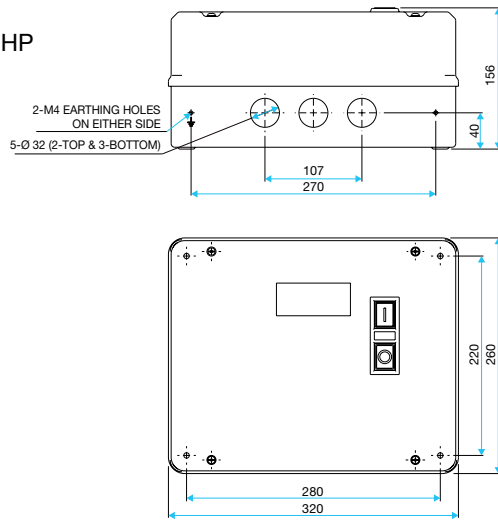

ASD Motor Starter 50HP - 100HP
Frame Size: 2

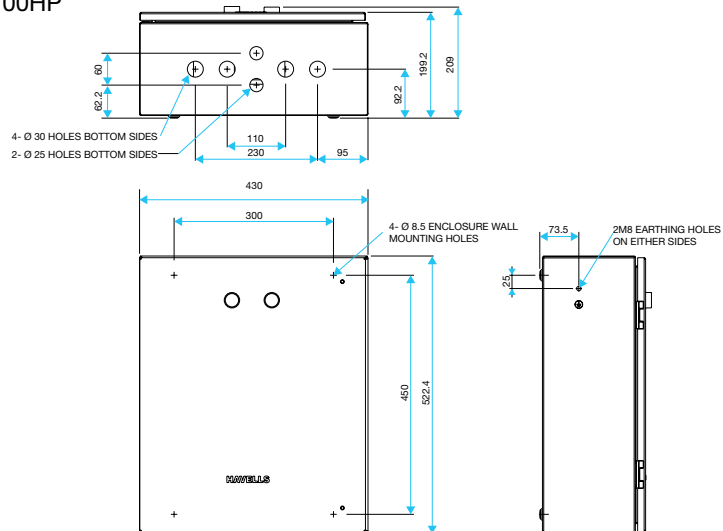

ASD Motor Starter 125HP & 150HP
Frame Size: 3

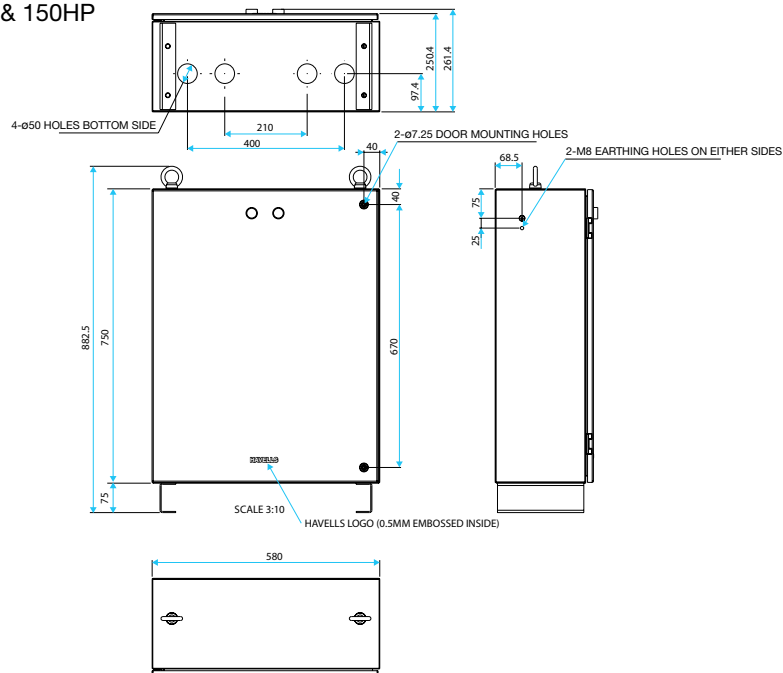

Dimensions (in mm)

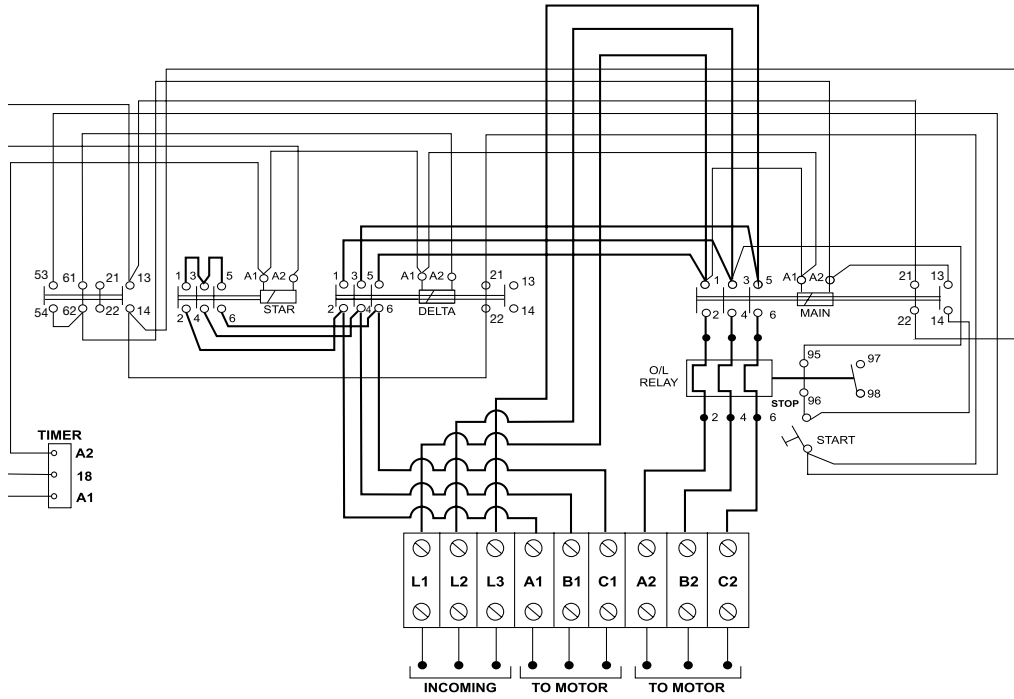

Dimensional Drawing DOL (Size in mm)

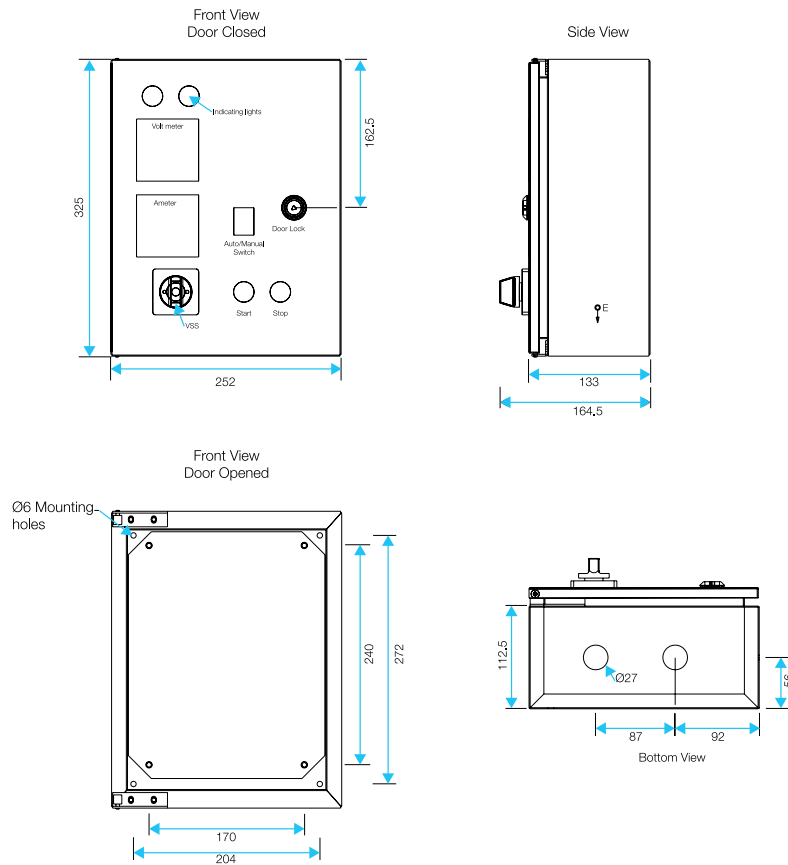

Circuit Diagram for DOL Submersible Pump Starter:

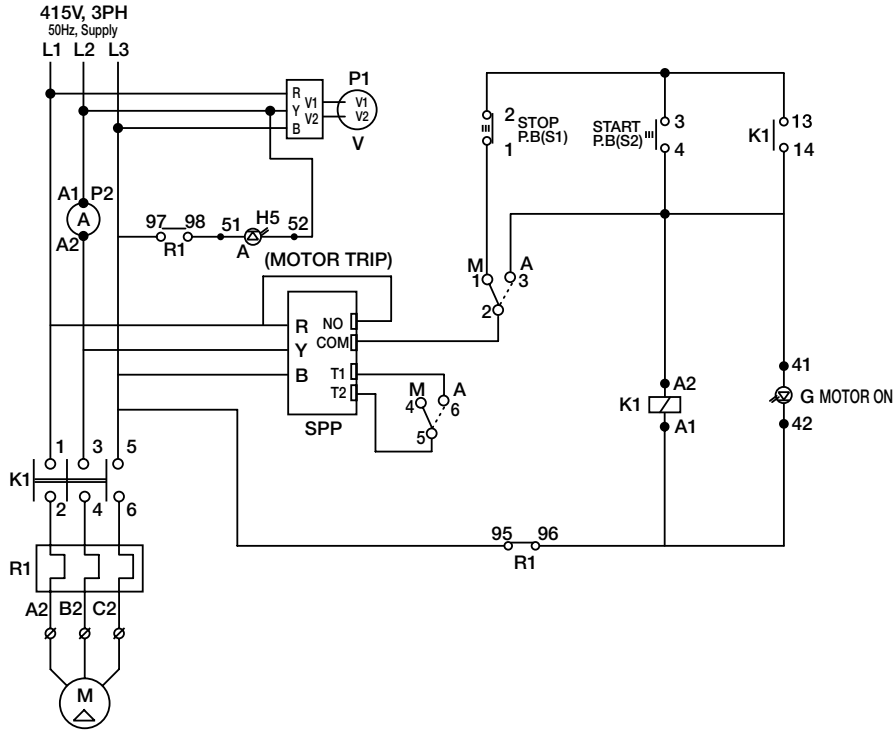

ASD Submersible Pump Starter 5HP - 25HP (Standard)

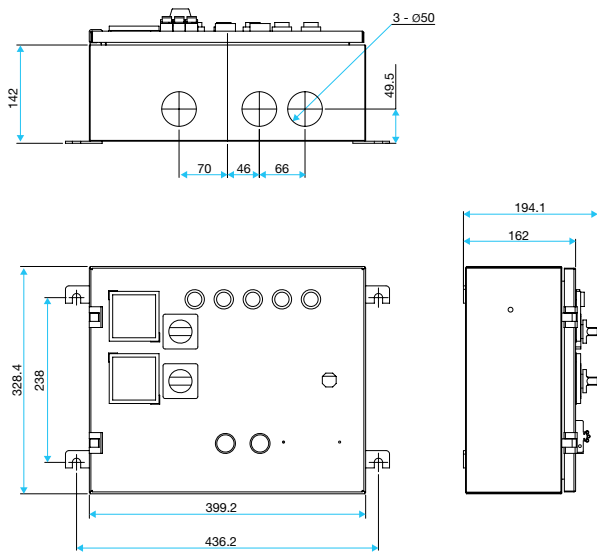

ASD Submersible Pump Starter 27.5HP - 45HP (Standard)

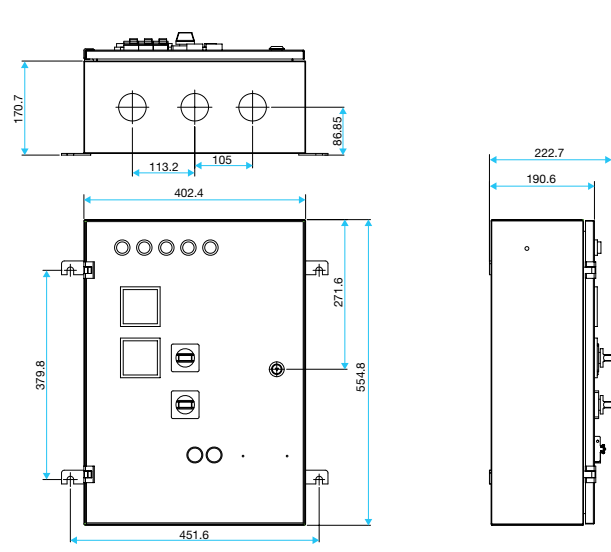

Dimensions (in mm)

Circuit Diagram for ASD Submersible Pump Starter (Standard)

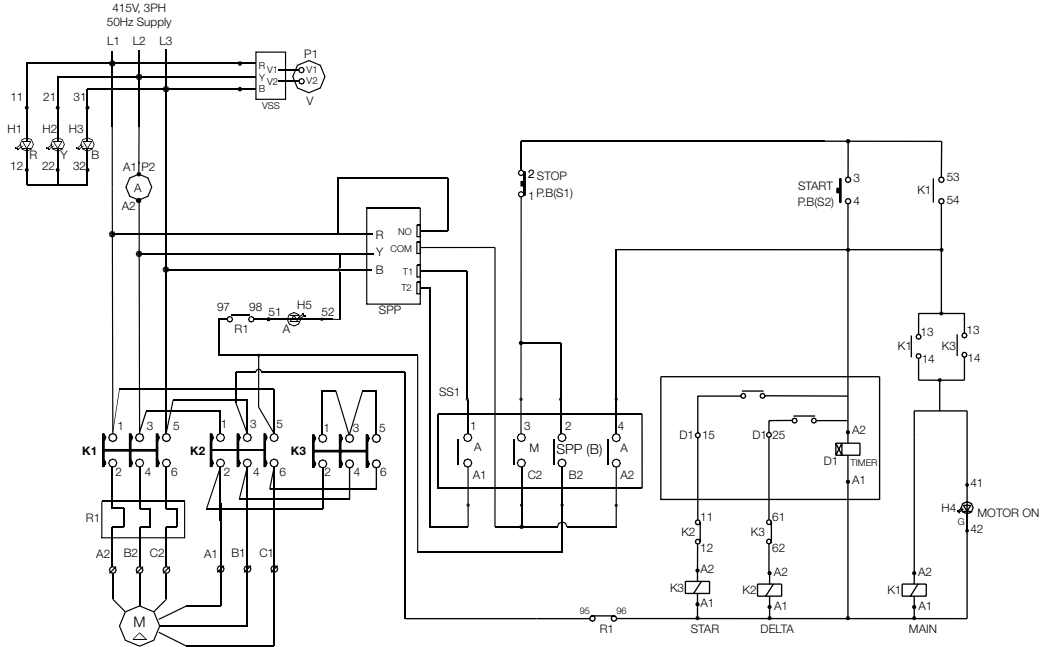

ASD Submersible Pump Starter 5HP - 25HP (Deluxe)

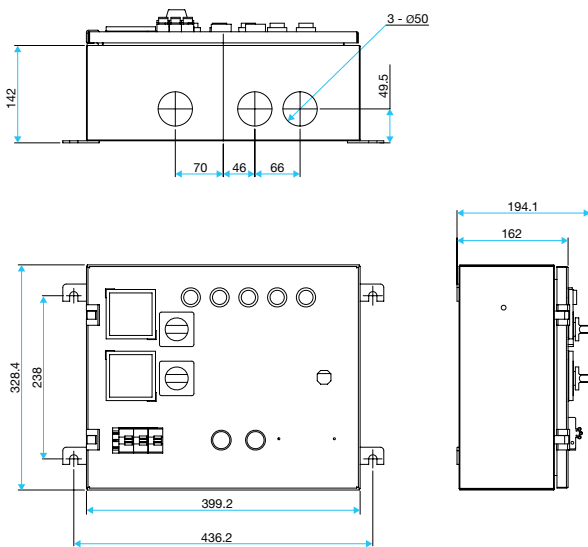

ASD Submersible Pump Starter 27.5HP - 45HP (Deluxe)

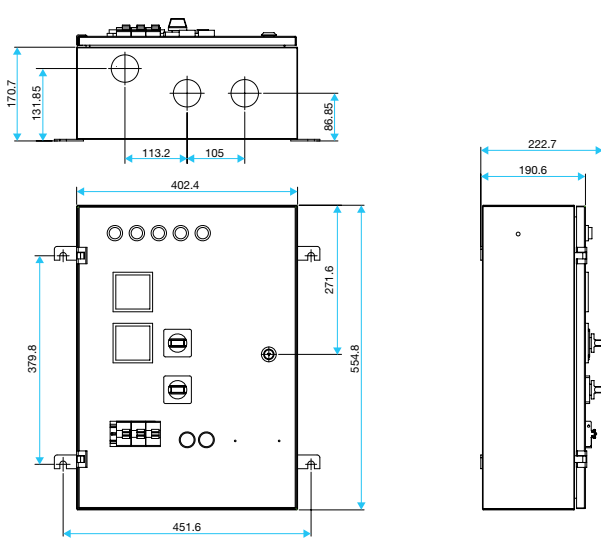

Circuit Diagram for ASD Submersible Pump Starter (Deluxe)

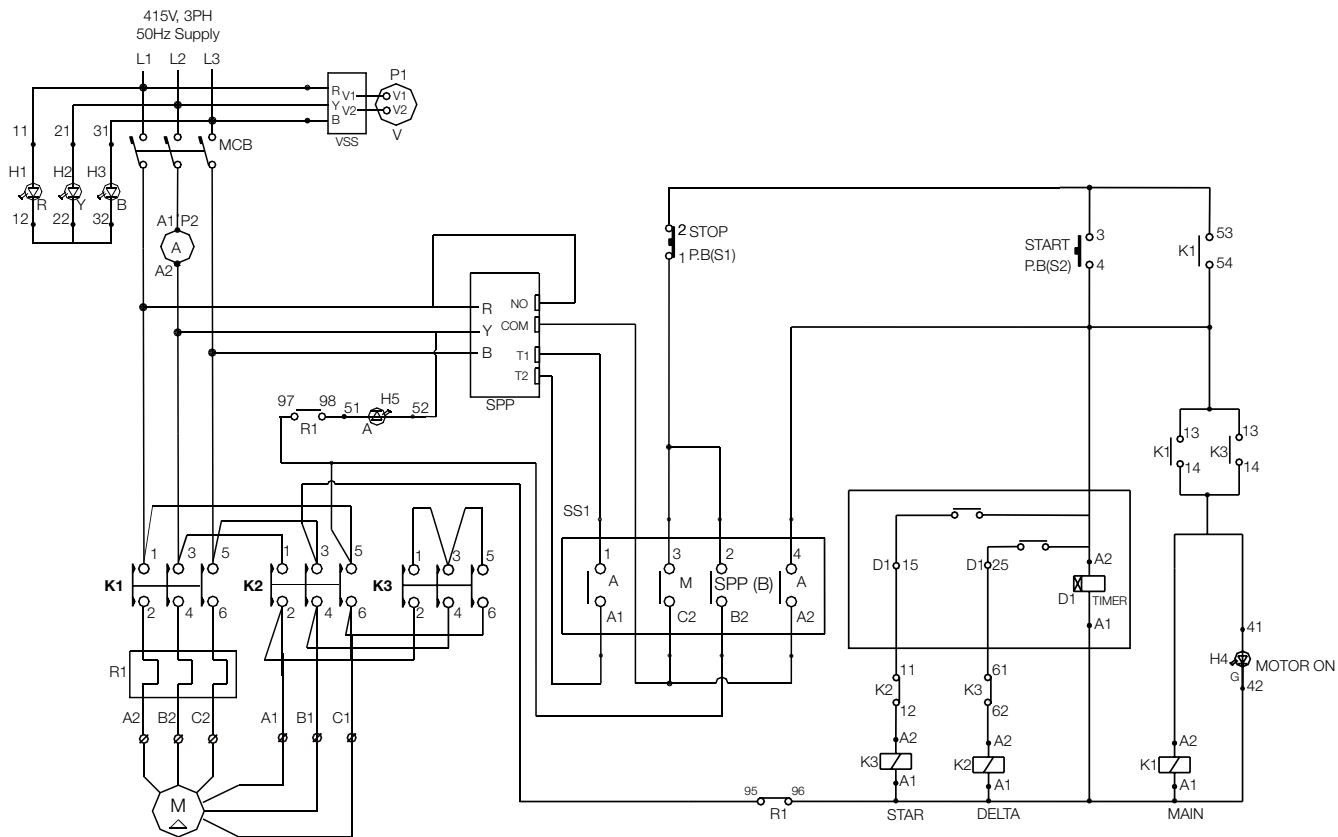

ASD Motor Starter Layout:

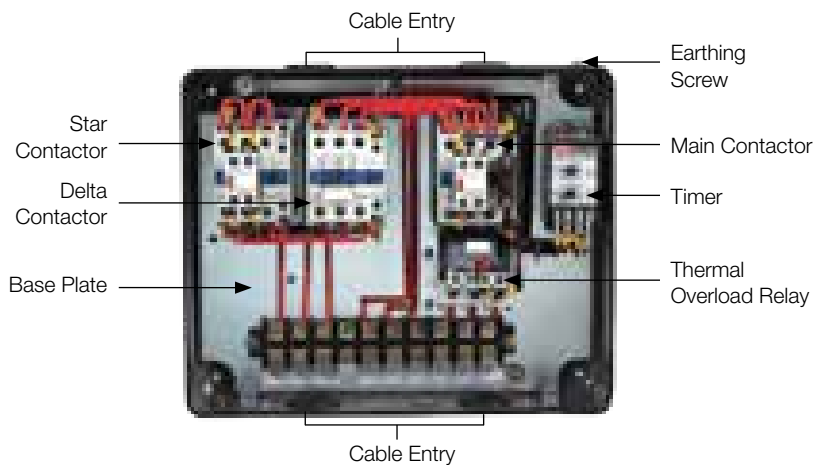
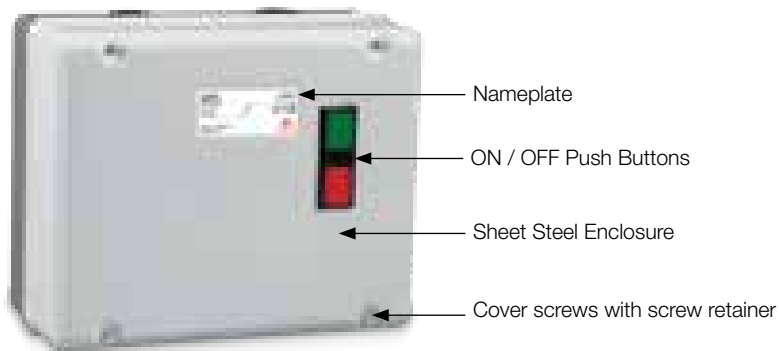

ASD Submersible Pump Starter Layout (Deluxe)

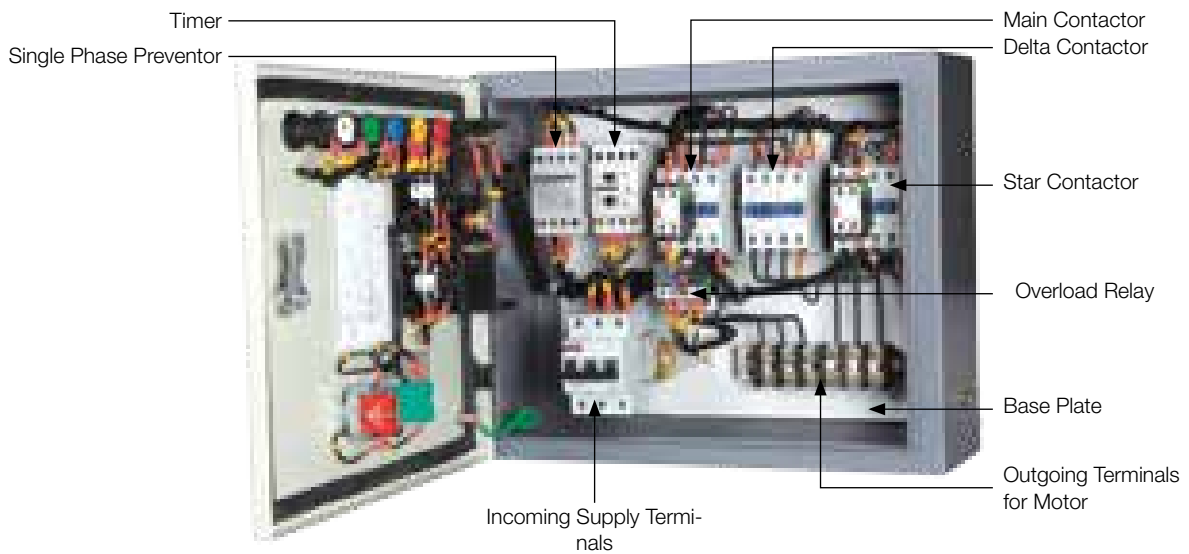
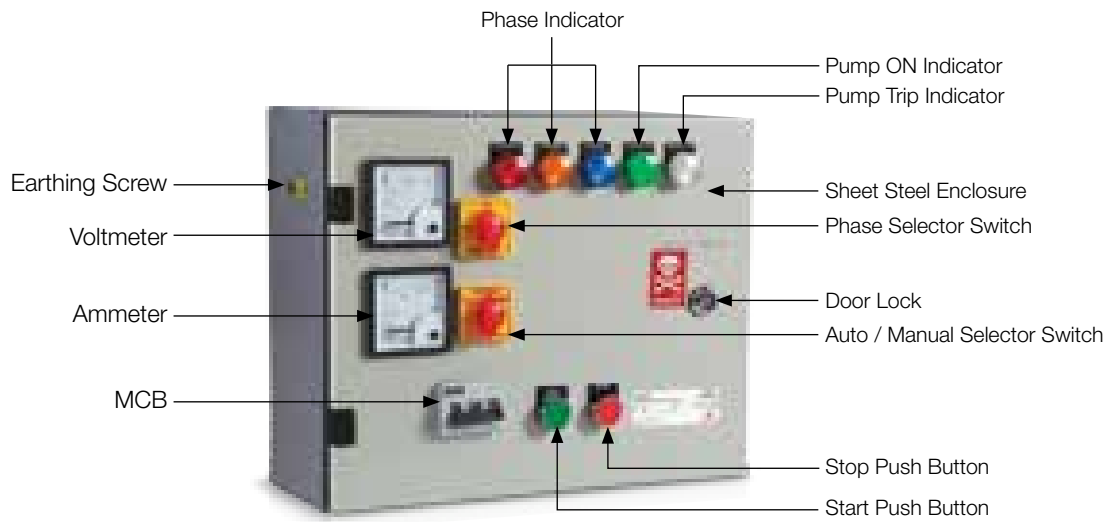

Agri Motor Starter

Features:

- Degree of Protection:
IP54 (Dust, vermin & waterproof) enclosure makes it suitable for use in almost all climatic conditions.
- Unique Wide Band Trip Coil:
In rural areas non-availability of stable voltage has always been a major concern to the farmers. To address and overcome this problem, the starter has been provided with a wide band trip coil (150V - 430V) which ensures that despite the fluctuation of voltage the starter does not trip and continues to remain in operation.

Range :

The starters are available from 0.5HP-15HP in two frame sizes suitable for 3Phase, 415V, 50Hz motors.

Specification :

Conforms to IS / IEC: 60947-4-1

Havells introduces the new Agri range of DOL motor starters. These starters are designed with smart & sleek powder coated deep drawn enclosure to suit the rugged Indian rural conditions for complete protection to pumps & motors and particularly useful for installations which are unattended requiring auto start facility.



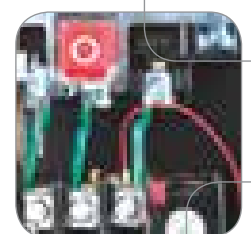
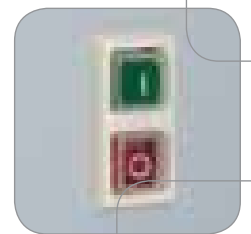

Construction

78



The starter comprises of a Mechanical Contactor in conjunction with a Thermal Bimetal Overload Relay mounted inside a Deep drawn CRCA sheet steel enclosure provided with an ON & OFF button. The Mechanical Contactor has no coil of its own therefore it does not require any voltage to energize and has to be switched ON/OFF manually (Press to switch ON & Press to switch OFF). The fixed & the moving contacts of the contactor can be replaced when required.

The Thermal Bimetal Overload Relay is Auto reset type and temperature compensated. The relay is provided with an adjustable current setting dial which can be set for a particular full load current. The starter is provided with an inbuilt Wide Band Trip Coil (150V – 430V) used for tripping purpose only. The coil comes into the circuit only in the event of an Overload/ Single phasing condition.

Internal View

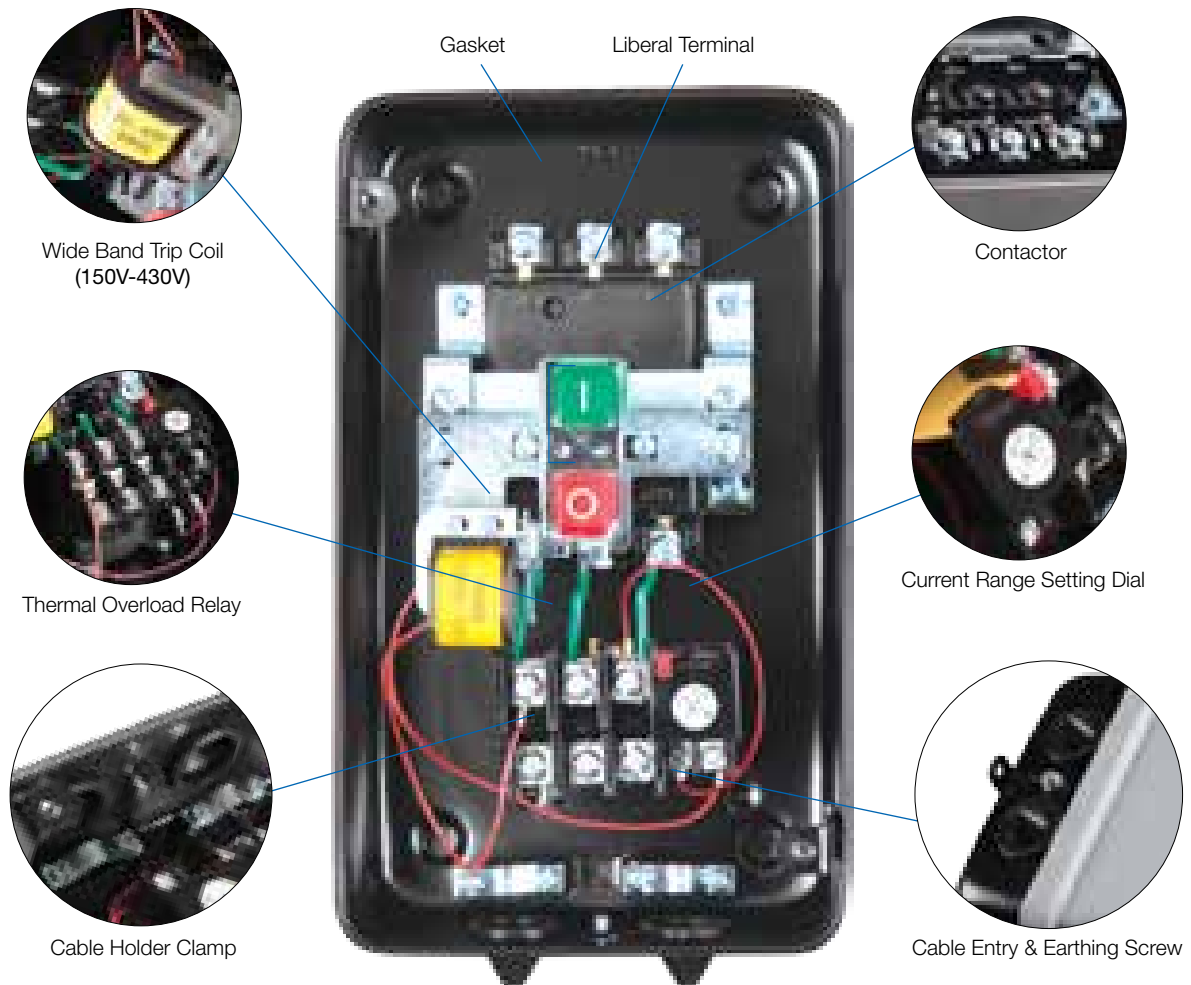

Features



DABANGG Motor Starters have been designed to provide complete protection to motors against **overload** - a condition that may be caused by different factors including low voltage. The starter mechanism is quick break and trip free. Silver tipped contacts ensure long electrical life. The starter with additional offering of a wide band trip coil (150V - 430V) provides stable operation even in adverse voltage conditions.

- **Degree of Protection:** IP54 (Dust, vermin & waterproof) enclosure makes it suitable for use in almost all climatic conditions.
- **Unique Wide Band Trip Coil:** In rural areas non-availability of stable voltage has always been a major concern to the farmers. To address and overcome this problem, the starter has been provided with a wide band trip coil (150V - 430V) which ensures that despite the fluctuation of voltage the starter does not trip and continues to remain in operation.
- **Auto Start on Power Restoration:** In the event of power restoration, the starter does not require to be switched on again.
- **Robust Construction:** The starter enclosure is sturdy, suitable for dusty agricultural environment.
- **Ease of Termination:** Provision of liberal terminals both at incoming contactor side & outgoing thermal relay side.
- **Ease of Maintenance:** Spare contact kit provides easy replacement of fixed and moving contacts.
- **Varied Applications:** Besides agriculture, these Motor Starters are specially suitable for motors in installations where no-volt coil is not required. Such installation include machine tools such as lathes, grinders, wood working machines etc. These are also widely used in AC chiller, textile machines & exhaust fans.

External View



Technical Information

Standard	:	IS / IEC 60947-4-1
Starter Type	:	Air Break
Rated Operational Voltage	:	415V AC
Rated Frequency	:	50Hz
Utilization Category	:	AC3
Degree of Protection	:	IP54
Mounting	:	Wall/ Surface Mounting
Cable entry	:	Bottom
Earth Connection	:	Bottom (External)
Enclosure material	:	CRCA Sheet Steel
Type of Overload Relay	:	Thermal Bimetallic
Relay reset	:	'Auto' only

Direct Online Starters (DOL)

Selection Chart

Motor Rating 415V, 3-Phase, 50Hz		Full Load Line Current (at 350V)	Contactor		Overload Relay		Backup Fuse Rating
HP	KW		Type	Rating (A)	Type	Range (A)	
0.5	0.4	0.85	DC1 20	20	DRT1A	0.68-1.1	2
0.75	0.6	1.28	DC1 20	20	DRT1B	1-1.6	4
1	0.7	1.70	DC1 20	20	DRT1C	1.5-2.4	6
2	1.5	3.41	DC1 20	20	DRT1D	3.2-5	10
3	2.2	5.11	DC1 20	20	DRT1E	4.5-7.2	16
5	3.7	8.52	DC1 20	20	DRT1F	6.8-11	20
7.5	5.6	12.77	DC1 20	20	DRT1G	10-16	25
10	7.5	17.03	DC1 20	20	DRT1H	14-22	32

Ordering Information

Selection Chart

Frame	Motor rating 415V, 3-Phase 50Hz		Contactor	Overload Relay		Motor Starter	
	HP	KW		Type/ Rating	Type	Range (A)	Type
1	0.5	0.4	DC1 20 / 20A	DRT1A	0.68-1.1	DS11	IHPDOAA1Y
	0.75	0.6	DC1 20 / 20A	DRT1B	1-1.6	DS12	IHPDOAB1Y
	1	0.7	DC1 20 / 20A	DRT1C	1.5-2.4	DS13	IHPDOAC1Y
	2	1.5	DC1 20 / 20A	DRT1D	3.2-5	DS14	IHPDOAD1Y
	3	2.2	DC1 20 / 20A	DRT1E	4.5-7.2	DS15	IHPDOAE1Y
	5	3.7	DC1 20 / 20A	DRT1F	6.8-11	DS16	IHPDOAF1Y
	7.5	5.6	DC1 20 / 20A	DRT1G	10-16	DS17	IHPDOAG1Y
	10	7.5	DC1 20 / 20A	DRT1H	14-22	DS18	IHPDOAH1Y

Contact Replacement



Untighten contactor cover screws



Remove cover



Keep aside the terminal screws along with the curved washers

For Fixed Contact replacement

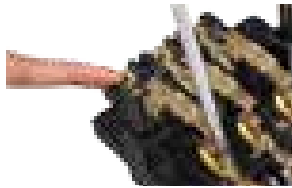

Untighten the above indicated screw



Remove the damaged fixed contact and replace with a new fixed contact

For Moving Contact replacement



With the help of a screw driver push the damaged moving contact from the bottom of the contactor.



Slide out the damaged moving contact and replace with a new moving contact.

Circuit Diagram

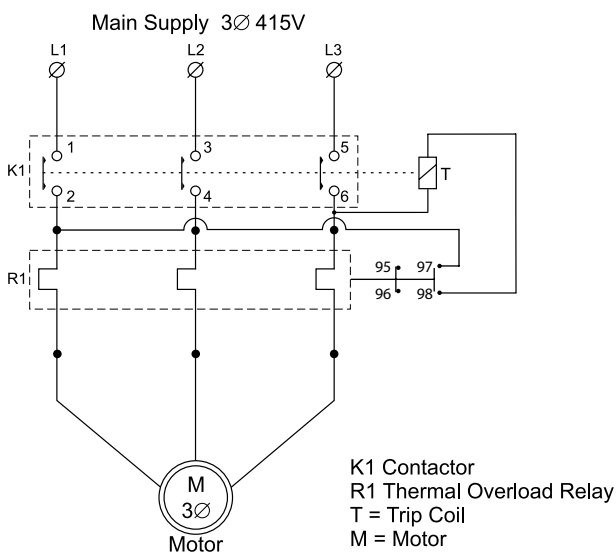

Dimension (in mm)

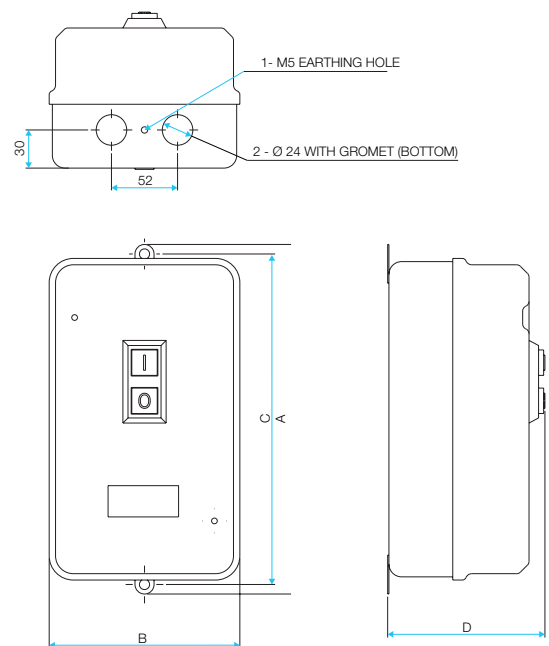

Street Light Panel

Features:

- Timer based system: Allows one to set the ON and OFF time. The switching of street lights can be repeated every day as per the set time through Programmable 24 Hrs Time Switch / Programmable Astronomical Time Switch
- Mode Selection: By Auto/ Manual Selector switch
- Panel Locking Facility: Provision of Door locking by Padlock and Panel lock
- Installation: Wall mounted / Floor Mounted
- Enclosure: CRCA Sheet Steel duly phosphatized and power coated
- Degree of Protection: IP 54 (Dust & Vermin proof)

Range :

- Three Phase (230V AC / per phase application) version in two frame sizes - Max. load 6kW & 12kW
- Single Phase (230V AC) version in single frame size - Max. load 6 kW & 12 kW

Specification :

IS 8623 / IEC 60439

IS 2147 / IEC 60529

Smart Street Lighting allows a city to easily schedule lights ON or OFF for individual or group of lights so that the city can intelligently provide the right level of lighting needed by time of day, season, or weather conditions.

Introducing Havells Street Light Panel that is specially designed for energy conservation in conventional street light systems.

Apart from energy saving, it also saves on Manpower, Operating Cost and reduces Manual Operating Errors.



Street Light Panel

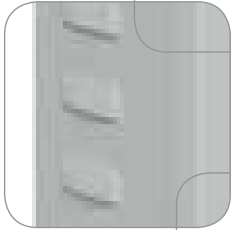
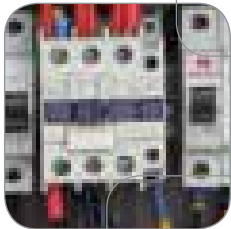

Introduction

Smart Street Lighting allows a city to easily schedule lights ON or OFF for individual or group of lights so that the city can intelligently provide the right level of lighting needed by time of day, season, or weather conditions.

Introducing Havells Street Light Panel that is specially designed for **energy conservation in conventional street light systems**.

Apart from energy saving, it also saves on Manpower, Operating Cost and reduces Manual Operating Errors.

Reference Standard:

- IS 8623 and IEC 60439
- IS 2147 and IEC 60529

Range

- Three Phase (230V AC / per phase application) version in two frame sizes - Max. load 6kW & 12kW
- Single Phase (230V AC) version in single frame size - Max. load 6 kW & 12 kW

Features

- **Timer based system:** Allows one to set the ON and OFF time. The switching of street lights can be repeated every day as per the set time through Programmable 24 Hrs Time Switch / Programmable Astronomical Time Switch

24 Hour Programmable Time Switch has a 24 hour dial and is used to switch an electrical circuit "ON" or "OFF" at selected times during a period of time programmed in advance. A program consists of a closing time and an opening time for a circuit.

Astronomical Programmable Time Switch automatically adjusts the set time along with seasonal variation to control ON / OFF for lighting on purpose of realizing that light is turned ON when sun sets & turned OFF when sun rises. This time switch is programmed on latitude base for whole year for sun rise and sun set timing.

- **Mode Selection:** By Auto/ Manual Selector switch
- **Panel Locking Facility:** Door locking by Panel lock and provision for Pad Locking available
- **Installation:** Wall mounted
- **Enclosure:** CRCA Sheet Steel duly phosphatized and powder coated with 7 tank process
- **Degree of Protection:** IP 32
- Pre-wired ready to use
- Liberal termination space
- Louvers provided on both sides for proper heat dissipation
- Manufactured by an ISO 9001 certified company

*IP 54 enclosure can be provided on request

Internal View

Three Phase Street Light Panel with 24Hrs / Astronomical Timer

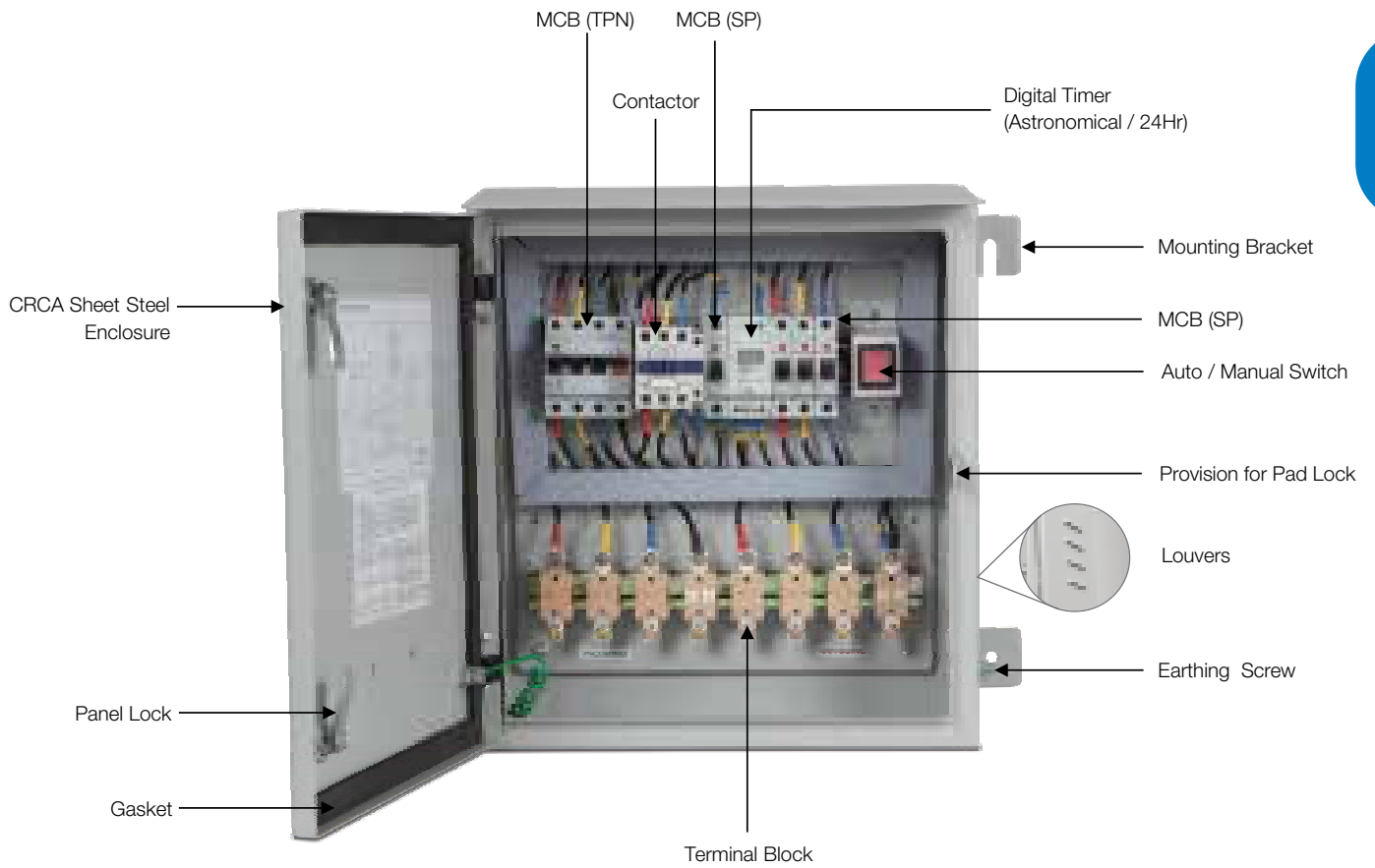

Single Phase Street Light Panel with 24Hrs / Astronomical Timer

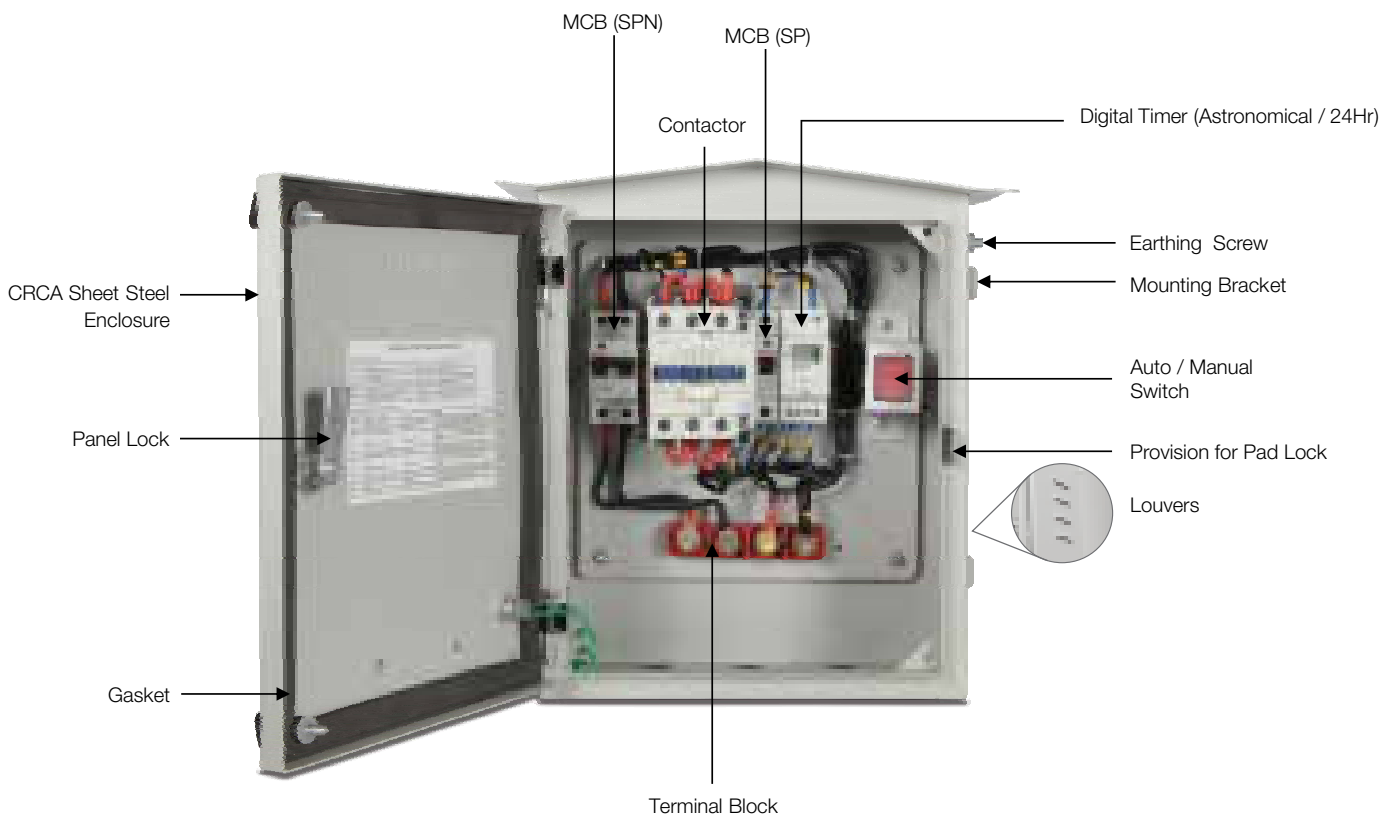

Technical Information

Timer Details

24 Hour Programmable Time Switch

Product Description

86



Technical Information	
Operating Voltage	220 - 240 Vac
Program Functions	ON / OFF
Number of Memory Locations	48
Power Reserve	150 Hrs
Max. Switching Capacity at 250 VAC, $\cos\Phi = 1$	16 A
Max. Switching Capacity at 250 VAC, $\cos\Phi = 0.6$	10 A
Incandescent / Halogen Lamps	2300 watt
Shortest Switching Time	15 Min

Operating Instruction

When the time switch is used for the first time, connect AC supply to input for 15 minutes & let the battery recharge. There after, press reset key.

Set the Present time

Step	Function	Key	Display
1	To set the Present time	Press P for 2 sec	Hour bit blinks
2	To select the Present hour	Press + or -	Hour bit increases/decreases
3	To save the hour & set the Present minute	Press OK	Minute bit blinks
4	To select the Present minute	Press + or -	Minute bit increases/decreases
5	To save the Present time	Press OK	Present Time

Programming for ON/OFF Time

Step	Function	Key	Display
1	To begin the setting	Press P momentarily*	Cursor starts blinking & display shows 00 : 00
2	To select the ON time	Press + or -	The time will increase/decrease by 15mins
3	To set this ON time	Press OK	Black cursor will be displayed at the ON time setting & time in the display will increase/decrease by 15mins
4	To select the next ON time	Press + or -	The time will increase/decrease by 15 min
5	To set this ON time	Press OK	Black cursor will be displayed at the ON time setting & time in the display will increase/decrease by 15mins
6	To set 2 – 48 ON/OFF time	Repeat step 1 – 3	Black cursor is displayed at the selected ON time
7	To end	Press P	Current time is shown in the display

Note*: If P is pressed for long, it will take the current time setting into account and hour bit starts blinking

Amend the ON/OFF Time

Step	Function	Key	Display
1	To begin the setting	Press P	Cursor starts blinking & display shows 00 : 00
2	To select the ON time which needs to be cancelled	Press + or -	Time is increased/decreased by 15 mins
3	To cancel the setting	Press OK	Cursor gets erased & time is increased/decreased by 15 mins
4	To end the setting	Press P	Present Time

Astronomical Programmable Time Switch

Product Description

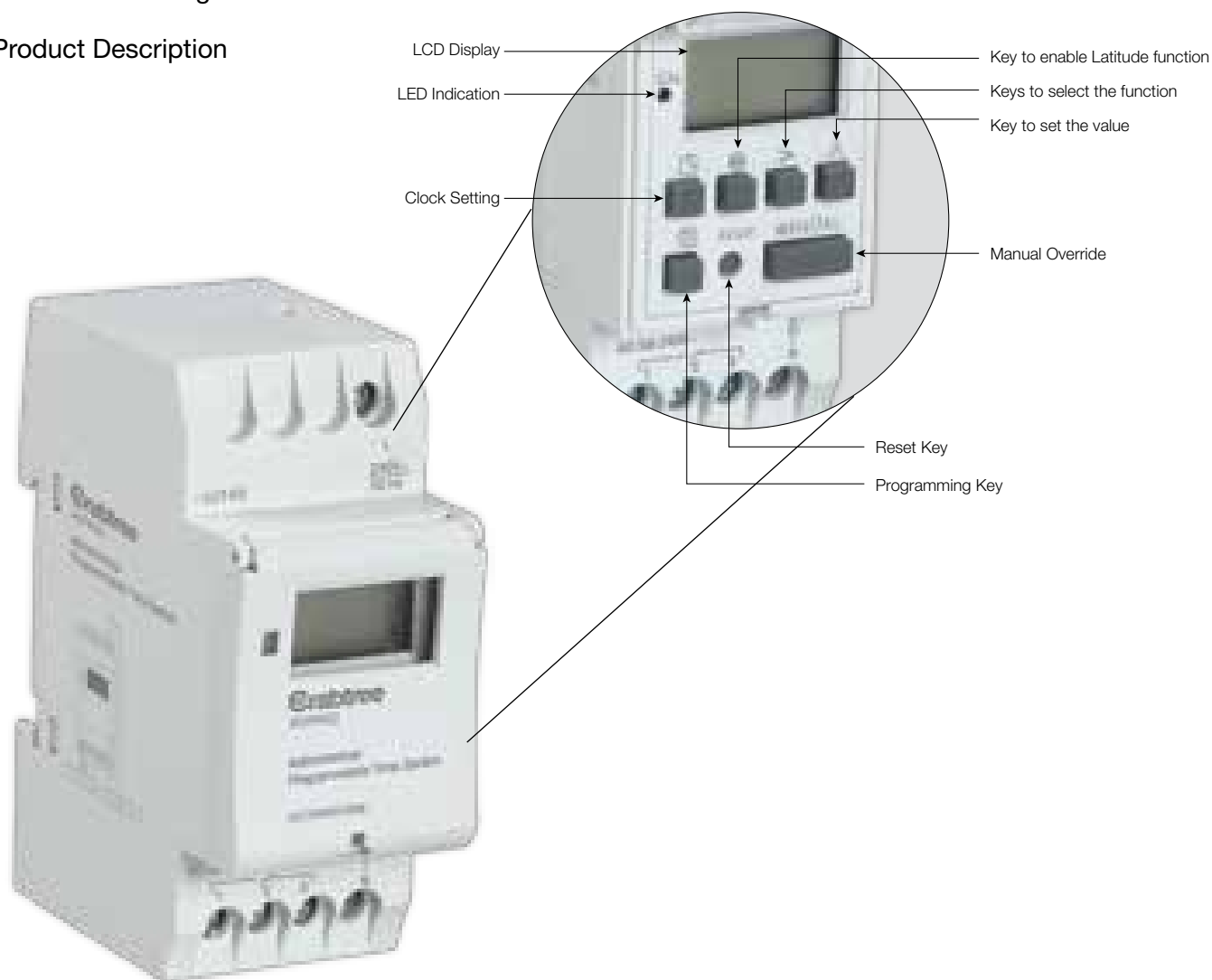

Technical Information	
Operating Voltage	240 Vac
Program Fuctions	ON / OFF
Number of Memory Locations	54
Power Reserve	48 Hrs
Max. Switching Capacity at 250 VAC, $\cos\Phi = 1$	16 A
Max. Switching Capacity at 250 VAC, $\cos\Phi = 0.6$	10 A
Incandescent / Halogen Lamps	1000 watt
Shortest Switching Time	1 Min

Operating Instruction

To install the time switch, find out the latitude of the region where the time switch has to be installed.

When the time switch is used for the first time, connect AC supply to input for 15 minutes & let the battery recharge.

There after, press reset key. After then, press reset key until the display shows L n 00 : 00 ☺

Set the latitude

S. No.	Function	Key	Display
1	To set the North/South half globe	Press >	n blinks
2	To change N – S	Press ^	n/s blinks
3	To set the latitude	Press >	00 blinks
4	To change the value	Press ^	Number increases by 1

Set the Present date

S. No.	Function	Key	Display
1	To set the Present date	Press P	d 01 : 01
2	To set the Present month	Press >	01 blinks
3	To change the value	Press & hold ^	Number increases by 1
4	To set the Present date	Press >	01 blinks
5	To change the value	Press & hold ^	Number increases by 1
6	To save the Present date	Press >	d Present date

Set the current time

S. No.	Function	Key	Display
1	To set the Present hour	Press ☉ and > simultaneously	t 00 : 00; hour bit blinks
2	To set the hour bit	Press & hold ^	Number increases by 1
3	To set the Present minute	Press ☉ and > simultaneously	Minute bit blinks
4	To set the minute bit	Press & hold ^	Number increases by 1
5	To save the time	Press >	Present time

Programming

S. No.	Function	Key	Display
1	To set the 1 st ON time	Press P	1 ON - - : - - ☉
2	To set the hour bit	Press >	Hour bit blinks
3	To change the value	Press ^	Number increases by 1
4	To set the minute bit	Press >	Minute bit blinks
5	To change the value	Press ^	Number increases by 1
6	To set the 1 st OFF time	Press P	1 OFF - - : - - ☉
7	To set the hour bit	Press >	Hour bit blinks
8	To change the value	Press ^	Number increases by 1
9	To set the minute bit	Press >	Minute bit blinks
10	To change the value	Press ^	Number increases by 1
11	To set 2 – 8 ON/OFF time	Repeat steps 1-10	

Note: If the latitude function is not needed, press ☉ until it extinguishes from the display, and now the time will not be adjusted as the day proceeds further.

Ordering Information

Selection Chart

Max. Per Phase Load kW	Contactor rating A	MCB rating A	Per Phase Max. no. of Light Points to be used				
			400W	250W	150W	70W	40W
6	32	40	8	12	20	43	75
12	65	63	15	24	40	86	150

Three Phase Street Light Panel

Frame Size	Max. Load (kW)	Contactor Rating (A)	MCB Rating (A)	Timer	SAP Code
1	6	32 / TP	40 / TPN	Digital 24hr	IHXTS03060
1	6	32 / TP	40 / TPN	Astronomical	IHXTS0306A
2	12	65 / TP	63 / TPN	Digital 24hr	IHXTS09120
2	12	65 / TP	63 / TPN	Astronomical	IHXTS0912A

Single Phase Street Light Panel

Frame Size	Max. Load (kW)	Contactor Rating (A)	MCB Rating (A)	Timer	SAP Code
1	6	32 / TP	40 / SPN	Digital 24hr	IHXSS01060
1	6	32 / TP	40 / SPN	Astronomical	IHXSS0106A
1	12	65 / TP	63 / SPN	Digital 24hr	IHXSS03120
1	12	65 / TP	63 / SPN	Astronomical	IHXSS0312A

Spares

Item	SAP Code
Digital 24hr Timer	DCTDD15016
Astronomical Timer	DCTBW01006
32A Contactor Coil 240V AC	ISPNCN4H
65A Contactor Coil 240V AC	ISPNCN6H

Dimensions (in mm)

Street Light Panel

Three Phase Street Light Panel

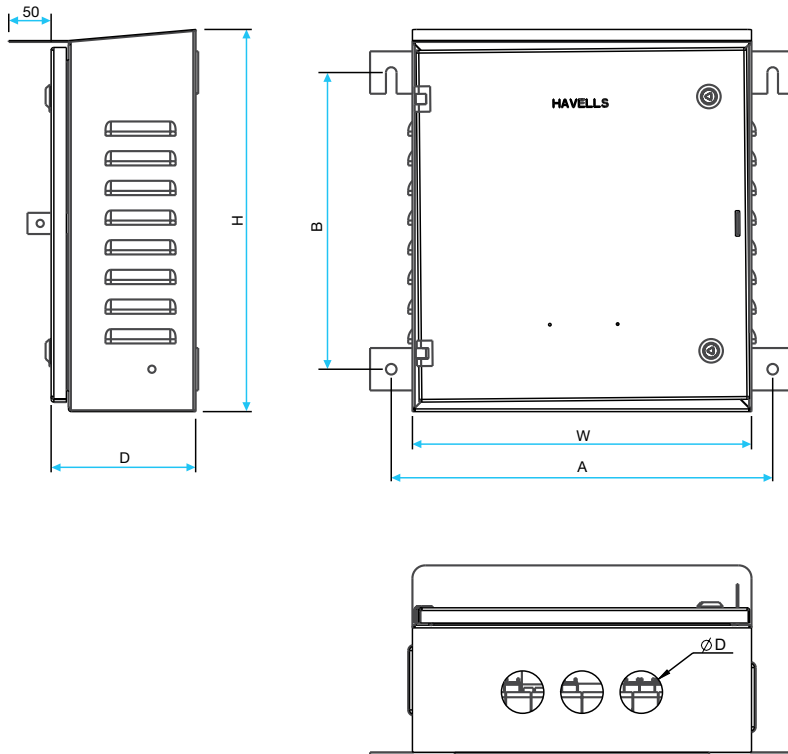

Frame	W	H	D	A	B	ØD
Size 1	400	450	170	450	350	50
Size 2	500	600	170	550	450	50

Single Phase Street Light Panel

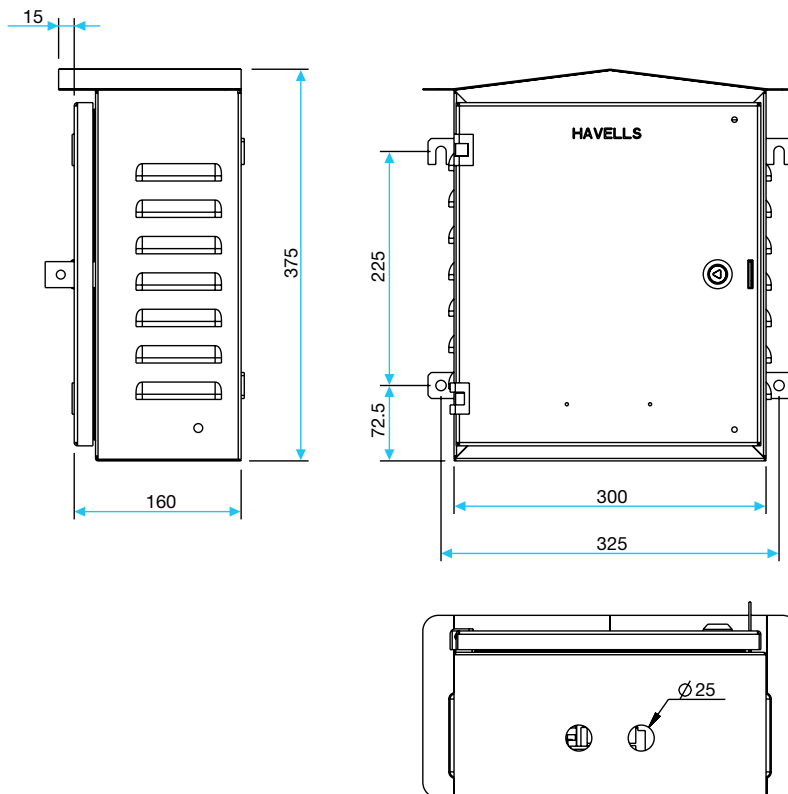

* Dimensions for 6 kW & 12 kW Single Phase Street Light Panel are common

Air Circuit Breaker

Features:

- Compact size, wide range & high breaking capacity
- 630A to 4000A available in only 3 frame sizes
- First frame available upto 2000A
- Common height, depth and panel door cutout
- Plug in type front accessible accessories
- Accessories are field fittable & common for the entire range
- Modular construction for pole unit
- Easily replaceable arcing contacts
- Available with communication facility

“Titania” range of Air Circuit Breakers are available from 630 A to 4000 A rating in 3 Pole and 4 pole execution, with breaking capacity of 50kA to 100kA. These ACBs have been designed keeping in mind the present day complex requirement of electrical systems which makes it essential to have a reliable product which can give un-interrupted service through out the product life meeting all the stresses that the system encounters.

C³ technology

630 A to 4000 A in 3 frame sizes
with 3 & 4 Pole execution



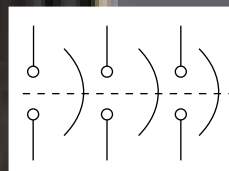

Construction

Operating Mechanism is of stored energy type, which operates using pre-charged springs. The springs are charged manually with the help of charging handle or with the help of charging motor, if provided. The same operating mechanism is used for the entire range. Mechanism has been developed using less number of parts resulting in more reliability, longer mechanical life and requiring very less maintenance.

Contact Mechanism

Conductor Unit is of modular design. Each pole consists of Main and Arcing contacts which are housed in the moulded housing. The contacts are made from sintered silver alloy for reliability, longer life and anti-weld properties. The construction of the contact is such that arcing contact closes before and opens later than the main contact, this substantially reduces erosion of main contact under normal and short circuit conditions.

The current transformer is placed inside the pole unit around the lower terminal.

Arc Chutes are provided for quenching the arc. Arc chute comprises of grid plates mounted in parallel in the insulated housing. The arc is divided between these grid plates which helps in its fast quenching. The arc is thus confined, divided and extinguished in the arc chute. The excellent insulation between the conducting parts and better energy dissipation after short circuit makes it possible to make the load and line connections on either side.

The **Tripping Mechanism** comprises of magnet holder trigger which is linked to the trip bar unit. The electronic circuit gives a signal to this unit in case of over current fault and this unit mechanically trips the Circuit Breaker.

In **Over Current Protection** the sensing of the current is through the current transformers fitted on the main terminals. In case of any fault the secondary output of the CT increases. This secondary output of CT goes to the micro controller based electronic circuit. The micro controller is programmed to give a signal as per inverse time characteristics. The signal in the form of DC supply is given to magnet holder trigger which trips the ACB. The required tripping time and tripping current can be set with the help of the switches provided on the front panel of the electronic release.

Internal View of ACB

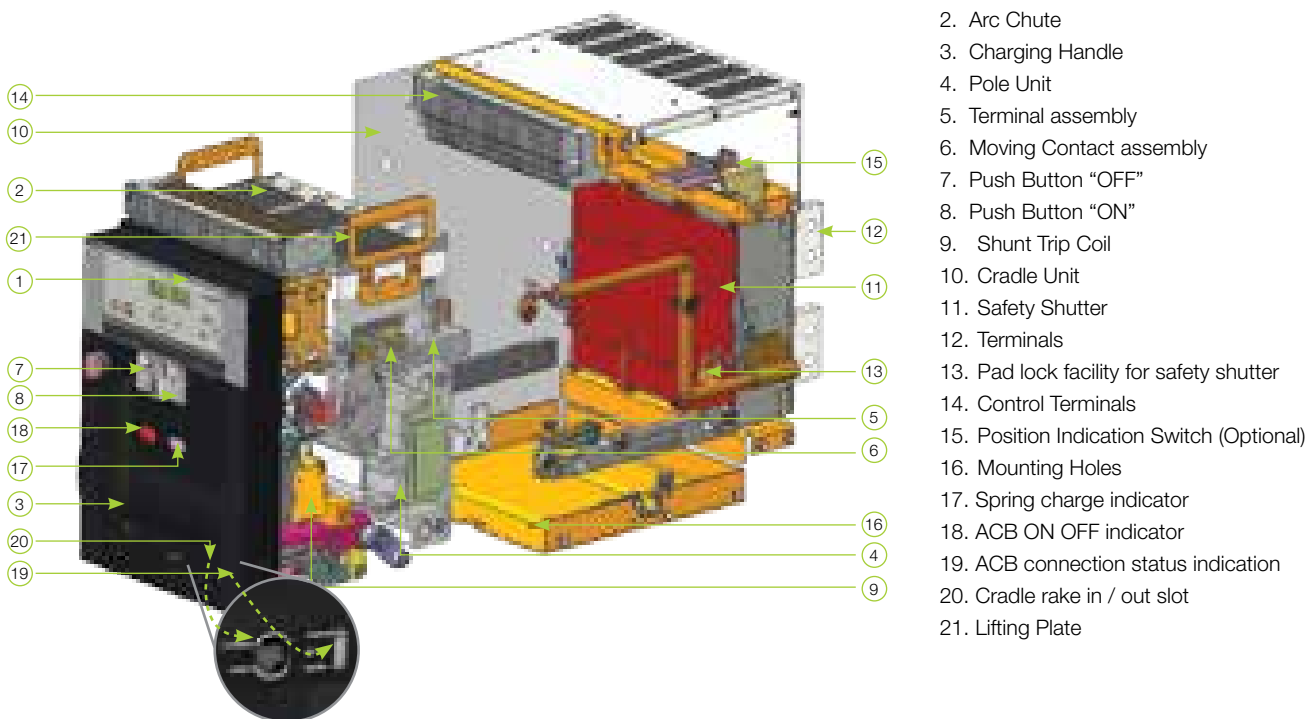

Technical Information

Standard Conformity : IEC 60947-2 & IS 13947-2

Performance Series		E	S	H	V
Rated Current (In) (Ref. Temp. 45°C)	(Amps.)	630	630	2000	2500
		800	800	2500	3200**
		1000	1000		4000**
		1250	1250		
		1600	1600		
		2000	2000		
Rated Service voltage (Ue)	V	690 VAC	690 VAC	690 VAC	690 VAC
		250 VDC	250 VDC	250 VDC	250 VDC
Rated Insulation voltage (Ui)	V	1000 V	1000 V	1000 V	1000 V
Rated impulse withstand voltage (Uimp)	kV	12 kV	12 kV	12 kV	12 kV
Frequency	(Hz)	50/60	50/60	50/60	50/60
No. of Poles*		3, 4	3, 4	3, 4	3, 4
Rated short-circuit breaking capacity (Ics=100%Icu)	(kA)	-220/380/415/440VAC	65	75	100
		-500/660/690 VAC	40	55	85
		-250 VDC	40	55	75
Rated short-time withstand current (Icw)	(kA)	1sec	50	65	85
		3sec	36	36	50
Rated short-circuit making capacity (peak value) (Icm)	(kA)	-220/380/415/440	105	143	220
		-500/660/690	84	121	143
Utilization category		B	B	B	B
Isolation behavior		Yes	Yes	Yes	Yes
Closing time (msec)		<70	<70	<70	<70
Break time (max) (msec)		30	30	30	30
Mechanical life (No. of operations) (with regular maintenance)		25000	25000	20000	15000
Electrical life (at 440VAC) (No. of operations)		630, 800A -15000	630, 800A -10000		
		1000,1250A -12000	1000,1250A -10000	10000	5000
		1600A -12000	1600A -8000		
		2000A -10000	2000A -8000		
Overall Dimensions (mm)					
Fixed (WxHxD)	3P		291x421x307	400x421x307	561x421x307
	4P		381x421x307	525x421x307	741x421x307
Draw out (WxHxD)	3P		330x460x386	435x460x386	600x460x386
	4P		420x460x386	560x460x386	780x460x386

* 2 Pole ACBs are available on request

** In 4 Pole ACB's 3200A and 4000A , Neutral Pole is available in both 100% or 50% rating.

Over Current Release



IPR range of over current releases (OCR) provided in Titania breakers are highly- reliable, multi-functional, dedicated protection unit using advanced micro-controller with full benefits of micro-processor technology offering Overload, Short Circuit, Instantaneous and earth fault protection besides enhanced feature of field testing for all models.

These releases are true RMS sensing over current trip devices, requiring no external supply for their basic functioning.

Salient features include :

- Error free and user friendly settings of current and time delay
- True RMS sensing with immunity to system disturbances
- More Reliable and repetitive accuracy, using high end 16 bit micro-controller
- Self powered by built in Current Transformer
- Three phase protection and Earth fault protection in same unit
- LED Indication for all the tripping faults
- Function 'OFF', setting available

Time-current Characteristic Curve

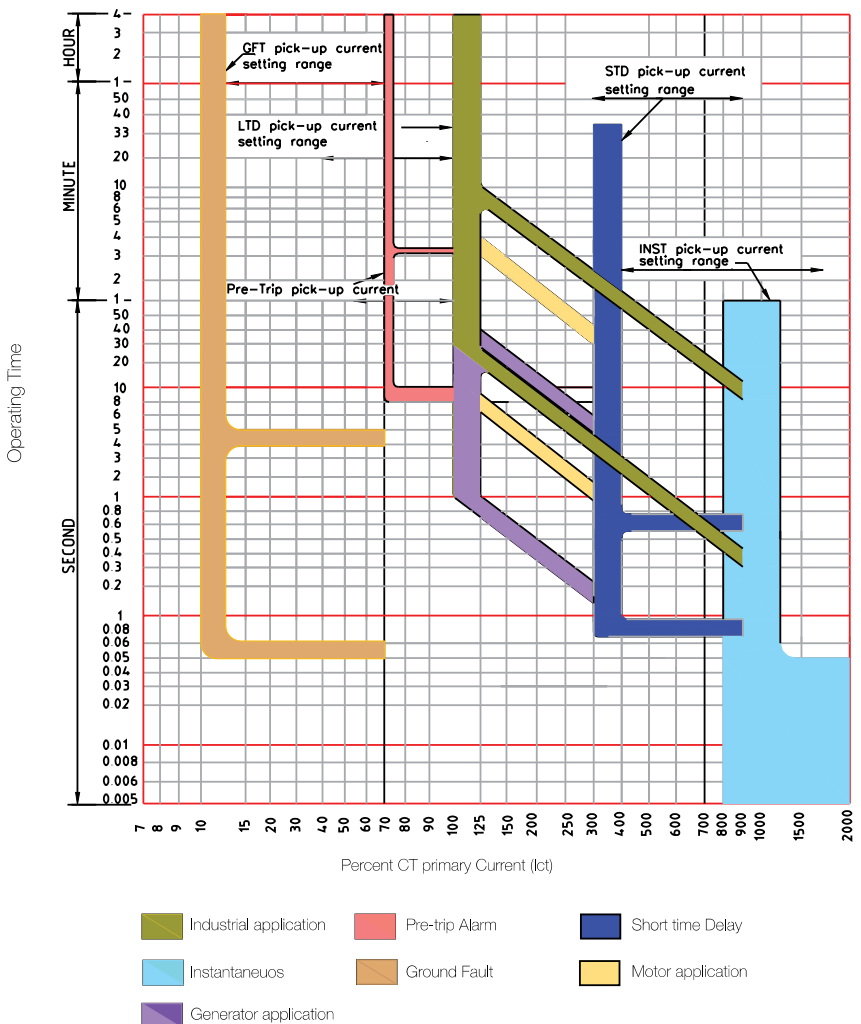

Specifications



Settings of Overload Current (LTD) LTD Current (I1) : 40% to 100% of ICT with function blocking option. LTD Time : 1sec to 35sec.

Settings of Short Circuit Current (STD) STD Current (I2) : 300% to 900% of I1 with function blocking option. STD Time : 50ms to 700ms.

Setting of Instantaneous Current (INST) INST Current (I3) : 400% to 1600% of I1 with function blocking option.

Ground fault Setting (GFT) GFT Current (I_g) : 10% to 70% of I1 with function blocking option. GFT Time : 100ms to 5000ms.

Besides these protection functions IPR-3 provides the following additional functions also:

RS Communication : Through RS485 Port

Pre Trip Alarm Function

Current Setting (I_p) : 60 to 100% of LTD current setting Time Setting (T_p) (definite) : 10 to 200 sec

Measurement function : 3 phase current, 3 phase voltage, Tripping time, KVA, KWH, Power factor, Max. demand (KVA & KWH), Breaker terminal temperature

Under Voltage/ Over Voltage Indication : Under Voltage setting from 40 to 85% of rated voltage, with a time delay of 50 to 400 msec. Over voltage setting from 110 to 150% with a time delay of 50 to 400 msec.

Fault History : To record and display the last 100 faults (50 faults in IPR2)

Self Monitoring : To monitor the condition of controller and in case of any fault same is indicated by "CPU FIT" LED.

Temperature Sensing : To monitor the temperature of Micro-controller and give an indication if the temperature exceeds the set value.

Breaker Fault : When any mechanical fault prevents the tripping of the fault zone breaker, the release of that breaker gives the tripping command to the upper zone breaker (if externally connected).

Potential Free Contacts : Potential free contacts for LTD, STD/INST, PTA, GFT, TEMP, under and over voltage.

LED Indications : LED Indications for faults.

Function Blocking : This feature is available for LTD, STD, INST and GFT

Operation Counter : It records the number of operations of ACB by counting the number of trip operations through OCR and stores them in 2 different categories: a) Current less than 300%, b) Current more than 300%.

Function Check : Field testing of LTD, STD & INST function can be performed with help of Field Testing Kit.

Specifications for IPR-E

LTD Current (I1) : 55% to 100% of ICT rating.

LTD Time : 5 Sec. fixed at 6In inverse time characteristics.

INST Current : Fixed at 6 In.



Features Available in Different Models of Over Current Release (IPR)



Functions	IPRE	IPR1	IPR2	IPR3
Overload Function (LTD)	•	•	•	•
Short Circuit Function (STD)		•	•	•
Instantaneous Function for short circuit protection (INST)	•	•	•	•
Ground fault Function (GFT)		•	•	•
Function blocking feature for all the above 4 functions		•	•	•
Pre trip alarm function			•	•
Measurement function				
• 3 phase current			•	•
• 3 phase voltage				•
• Tripping time				•
• KVA				•
• KWH				•
• Power factor				•
• Max. demand (KVA & KWH)				•
• Ambient temperature				•
• Breaker terminal temperature				•
Under voltage / Overvoltage alarm				•
Fault History			•	•
Self Monitoring			•	•
Temperature sensing				•
Breaker fault			•	•
Potential free contacts			•	•
LED Indications	•	•	•	•
Operation counter			•	•
Function Check	•	•	•	•
LCD display			•	•
Communication Port RS 485				•

• Available

Communication Facility



Intelligent over current microprocessor release type IPR3 is available with two way communication facility through RS232/485 port. The communication facility enables the user to monitor the entire system from his controlroom on a PC/Laptop. Through this facility it is also possible to control/modify the setting of the IPR release from the PC/Laptop as per the user requirement. The complete fault history record can also be stored in the computer. The software required for this system is offered by Havells as optional.



◀ Online information of ACB



◀ Modification of release parameters from computer

Wattloss Chart (Total for 3 Pole ACB)

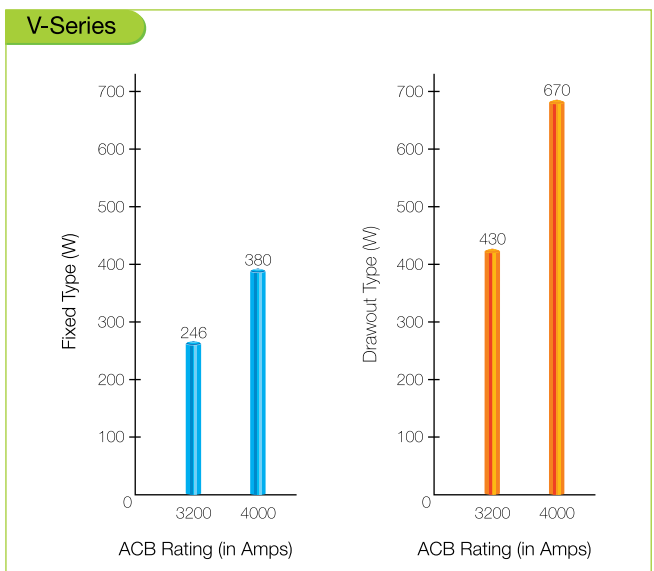
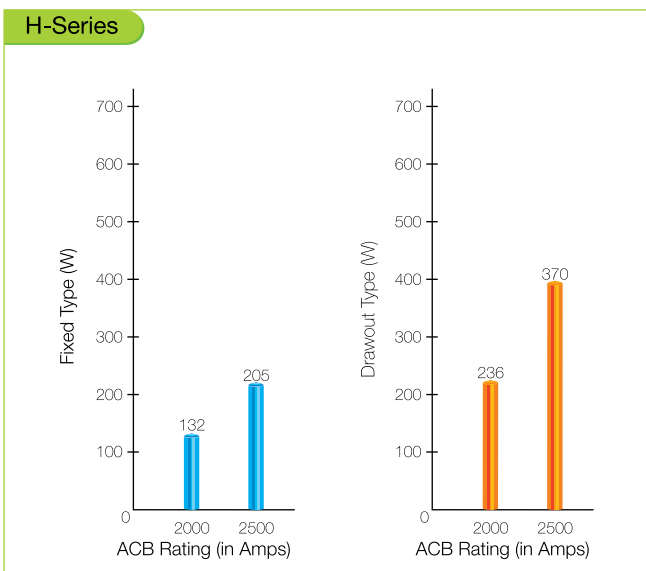
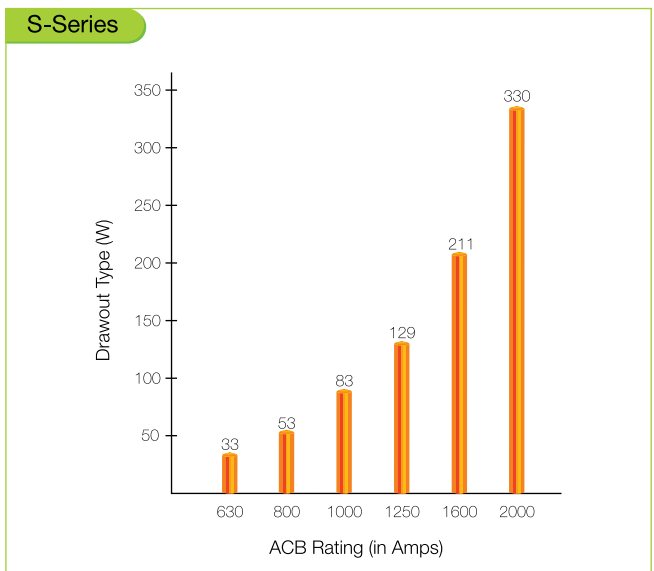
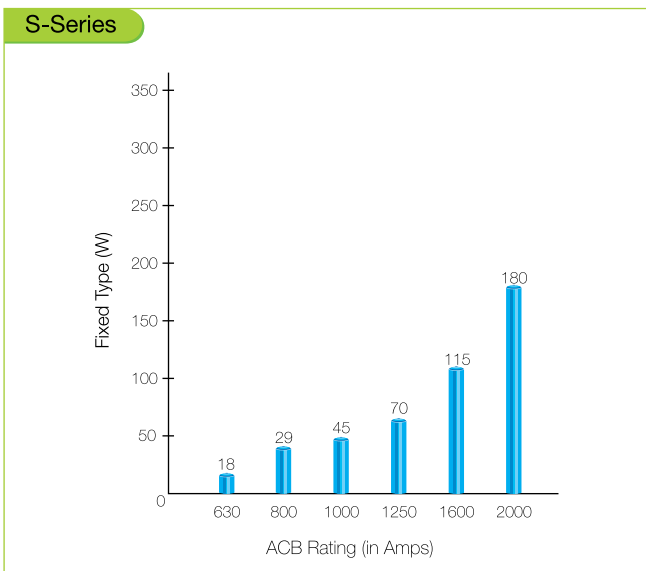
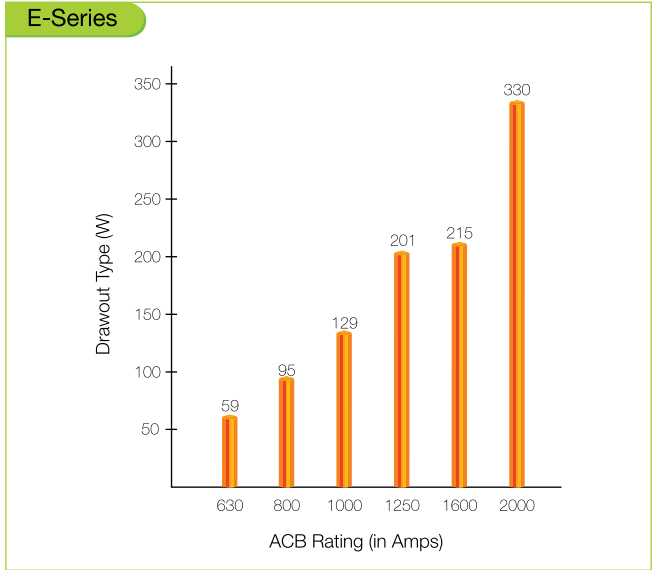
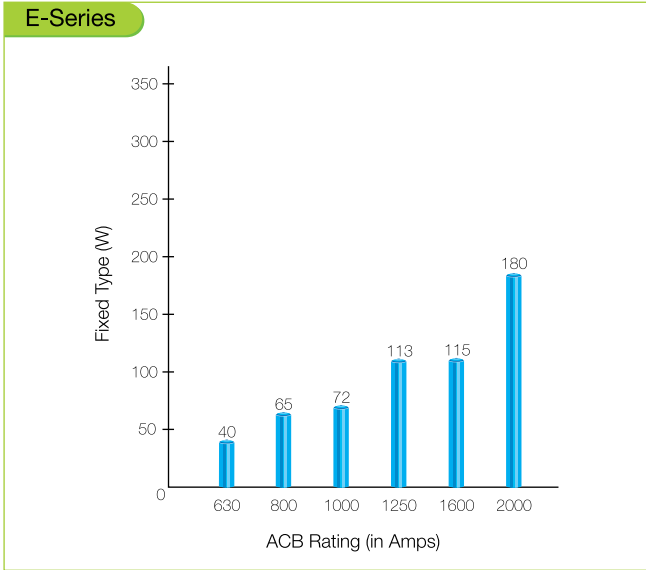

Accessories

Electrical Accessories:



Charging Motor:

It is provided in an electrical operated ACB to charge the closing springs automatically. These are available in 110V and 220V AC/DC. The VA burden of this motor is 150 VA only and the charging time is 3 to 4 seconds.



Shunt Trip Coil / Closing Coil:

These coils are used for electrical tripping and closing of ACB. These coils are available in 24V, 110VAC/DC, 220VAC/DC & 415VAC. The same coil can be used as a shunt trip coil or closing coil. The inrush power is 200VA.

These coils are used for electrical tripping and closing of ACB. These coils are available in 24V, 110VAC/DC, 220VAC/DC & 415VAC. The same coil can be used as a shunt trip coil or closing coil. The inrush power is 200VA.

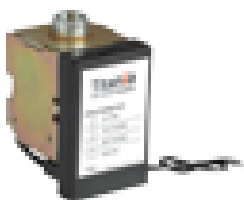

Undervoltage release:

This release trips the ACB in case the voltage drops below the required level. It is necessary to energise the under voltage release coil before attempting to close the circuit breaker as in de-energized condition, it mechanically locks the breaker and the same can not be closed. These coils are available in 24V DC, 110V AC/DC, 220V AC/DC & 415V AC.

For energizing this coil minimum 85% of the rated voltage is required and if the voltage drops below 50% of the rated voltage it automatically trips the ACB. Inrush power of this coil is 200VA and the continuous power is 5VA only.



Auxiliary Contacts:

A set of five changeover switches are provided in the circuit breaker which can be used for external circuit. Additional five changeover switches can also be provided as an optional.

Drawout Accessories:

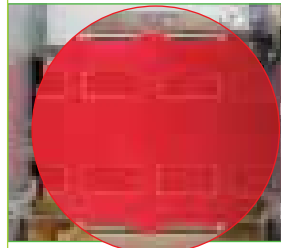

Safety Shutter for main circuit:

It is provided on the cradle which automatically isolates the Main circuit terminals when the breaker is drawn out. A provision is also there for locking the safety shutter in the closed position with the help of Pad Lock (not supplied with ACB).

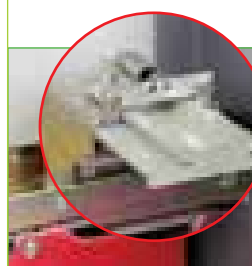

Position Indication Switch:

A set of 5 micro switches is provided in the cradle which indicates the position of breaker in the cradle i.e. CONNECTED, TEST, or DISCONNECTED position. Two switches each are provided for CONNECTED AND DISCONNECTED position and one switch is for TEST position.

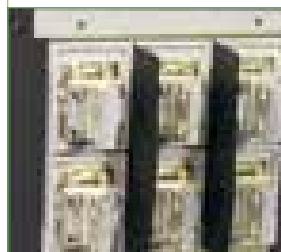

Adaptor terminals for Cradle:

Special Adaptor Terminals can also be provided for 1st frame ACB which can make the terminals suitable for taking horizontal as well as vertical bus bar connections. The standard cradles are supplied with horizontal terminals. Adaptor terminals are factory fitted and are available at extra cost.

Mal insertion prevention device:

It prevents the breaker of a different rating being inserted into the cradle of different rating.



Drawout position lock:

This feature is available to lock the breaker into different drawout positions i.e. CONNECTED, TEST, or DISCONNECTED position with the help of padlock (not supplied with ACB).

Accessories

Other Accessories:

102



Close open cycle Counter:

It indicates the number of mechanical operations of the circuit breaker and the same is visible on the front of ACB Cover.



Spring charge Indication Switch:

A micro switch is provided to get a remote signal indicating the status of Circuit Breaker closing spring.



Key Lock/ Key Interlock:

It is provided to lock the ACB in open position. Once the ACB is locked it can not be switched on. For interlocking purpose three locks with two keys or two locks with one key can be supplied.



Door Interlock:

It prevents the opening of panel door, if the ACB is in closed (ON) position. When this interlock is fitted in the Circuit Breaker it is necessary to switch off the breaker, before opening the panel door.

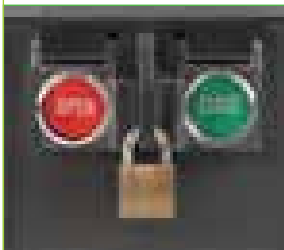

ON/OFF push button cover:

A special cover can be provided on the front cover on which a pad lock (not supplied with ACB) can be fitted for locking the ON & OFF push buttons.

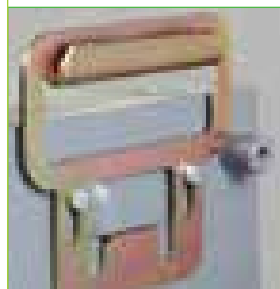

Lifting Plates:

Titania Air Circuit Breakers are fitted with specially designed lifting plates which makes the lifting of these ACBs very convenient.

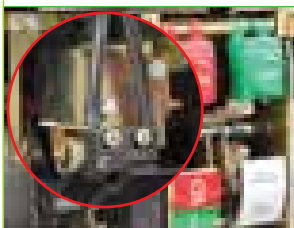

Trip Indication Switch:

It is provided to get a remote signal indicating that ACB has tripped due to the operation of over current release.

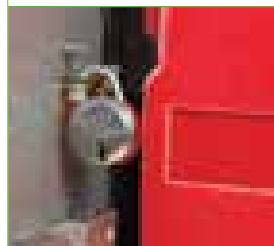

Safety shutter padlock feature:

For the safety of the personnel, safety shutter can be padlocked once the breaker has been withdrawn from the cradle.

Out Line Dimensions, Mounting Detail & Terminal Arrangement

Rating: 630A to 2000A (E & S Series) Fixed Type

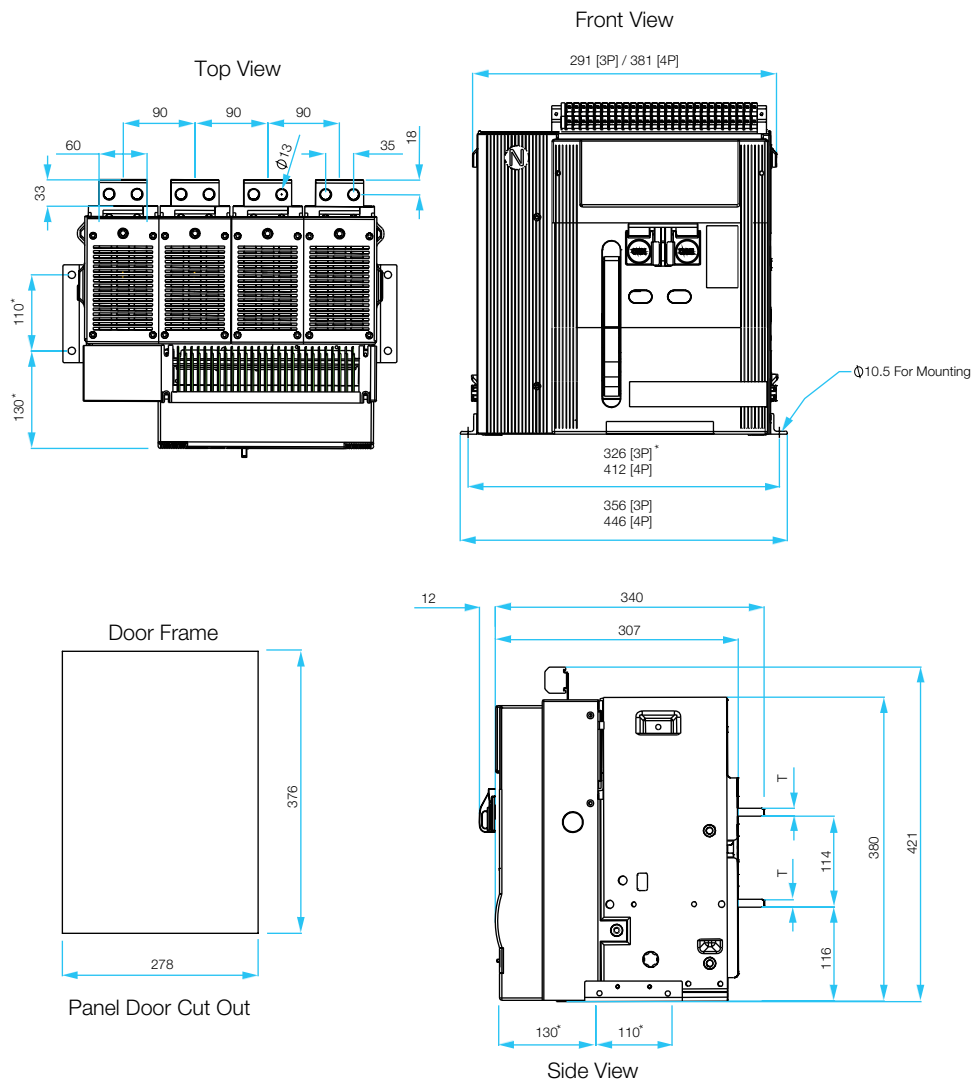

* Mounting hole dimensions
All dimensions are in mm.

Thickness - 'T'		
	E- Series	S- Series
630-800A	10	20
1000-1250A	15	20
1600A	20	20
2000A	25	25

Out Line Dimensions, Mounting Detail & Terminal Arrangement

Rating: 630A to 1600A (E & S Series) Drawout Type

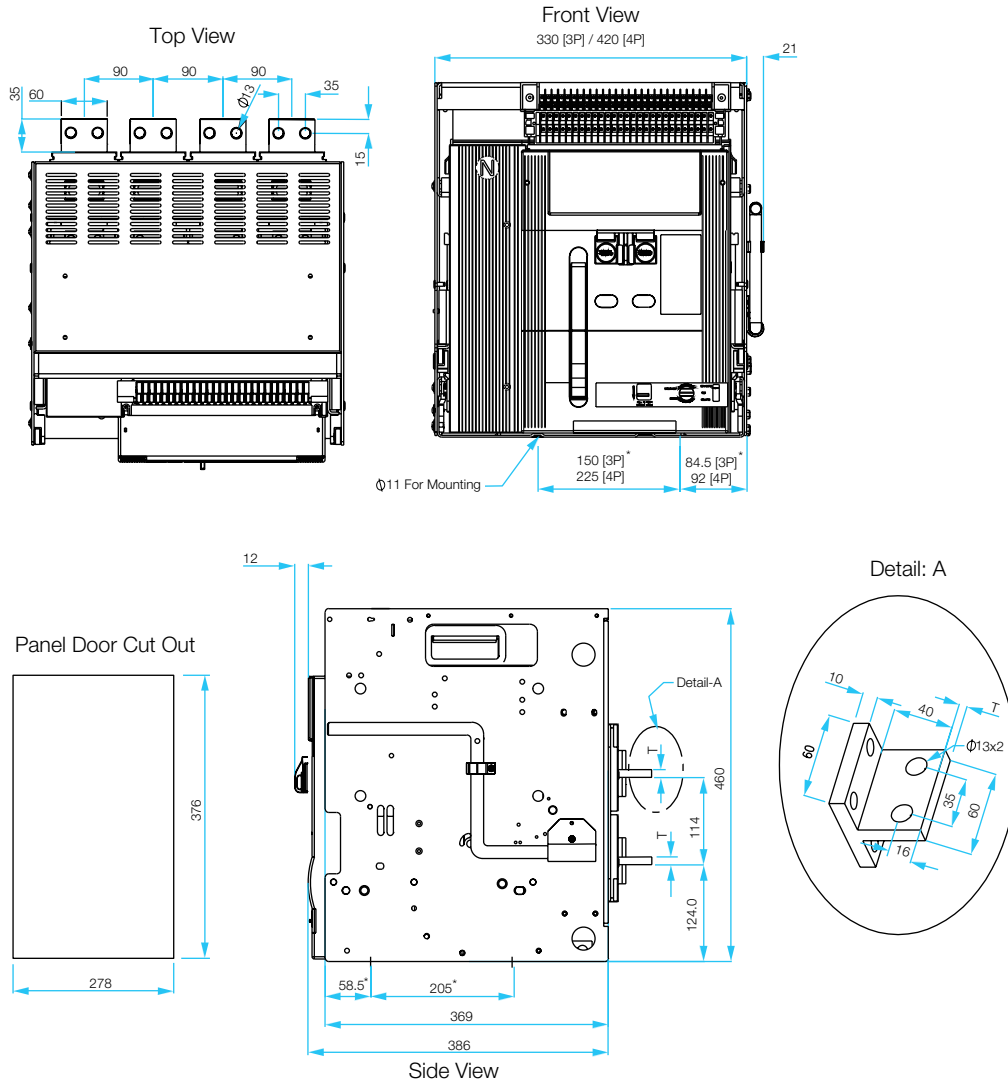

* Mounting hole dimensions
All dimensions are in mm.

Thickness - 'T'		
	E- Series	S- Series
630-800A	10	20
1000-1250A	15	20
1600A	20	20
2000A	25	25

Out Line Dimensions, Mounting Detail & Terminal Arrangement

Rating: 2000A (E & S Series) Drawout Type

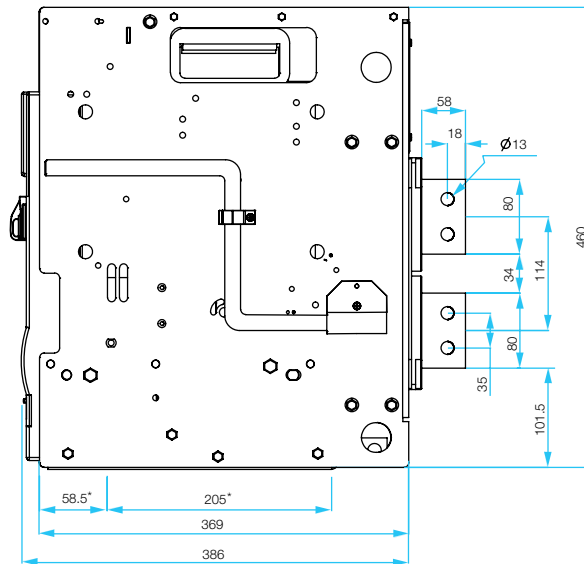
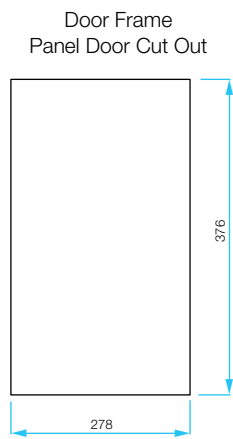
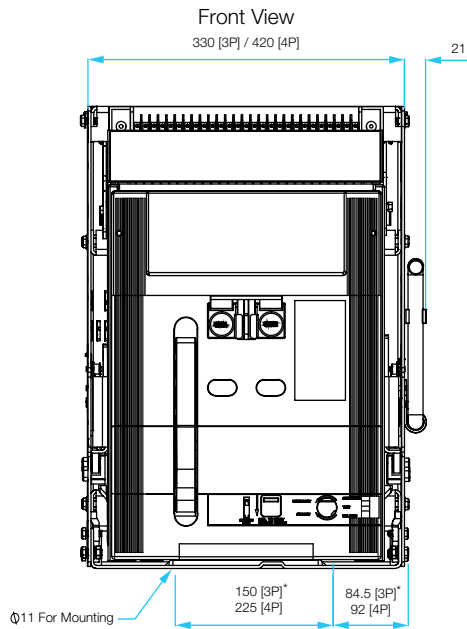
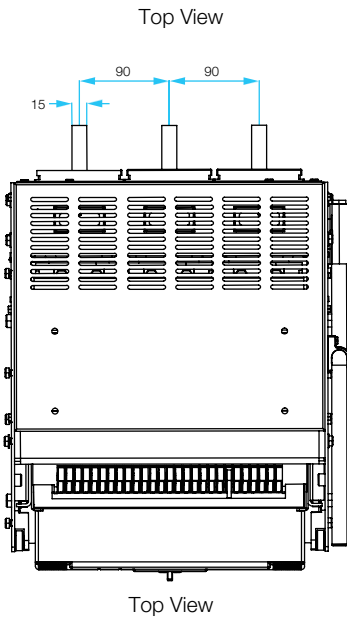

Out Line Dimensions, Mounting Detail & Terminal Arrangement

Rating: 2500A (H Series) Fixed Type

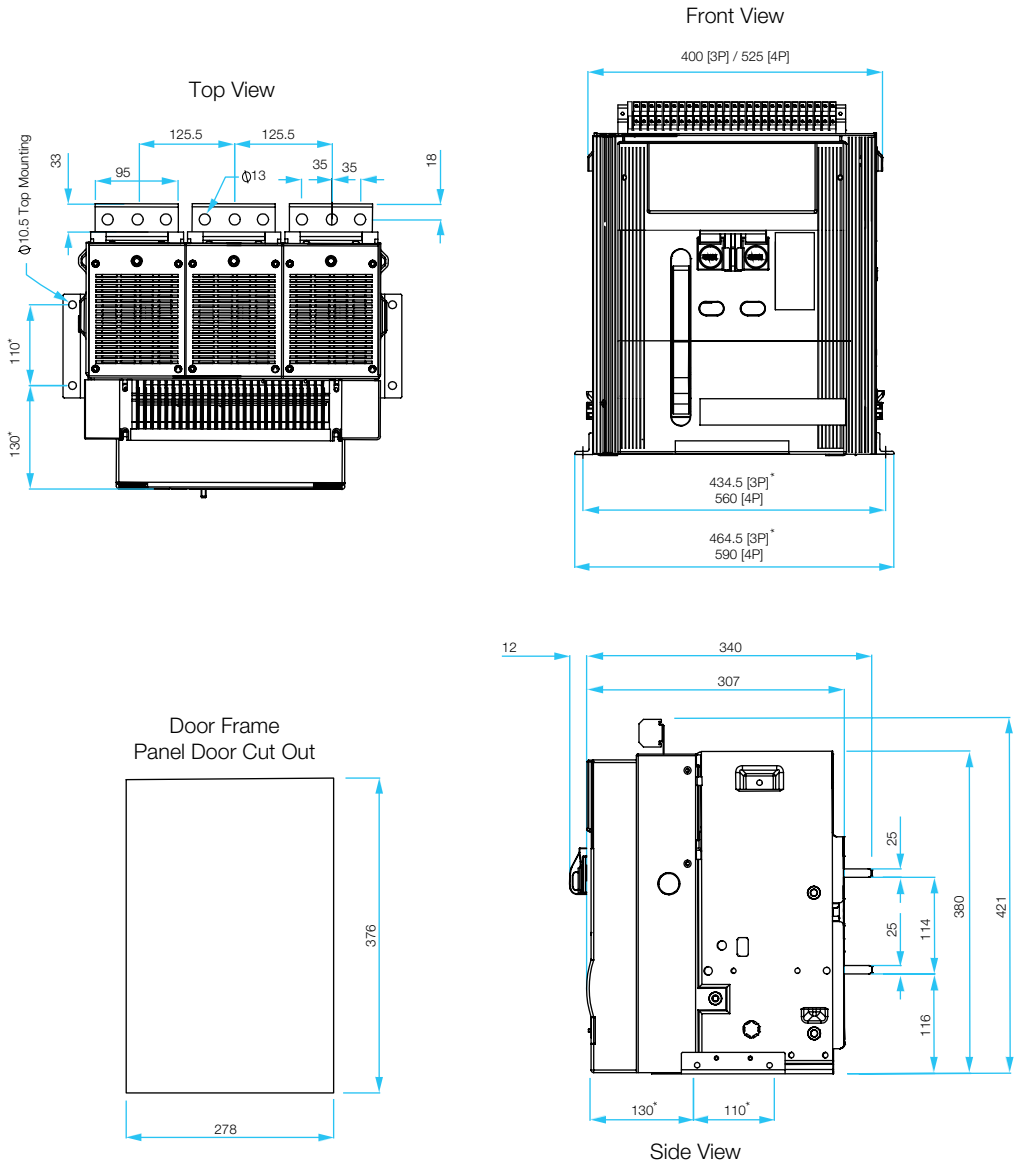

* Mounting hole dimensions
All dimensions are in mm.

Out Line Dimensions, Mounting Detail & Terminal Arrangement

Rating: 2500A (H Series) Drawout Type

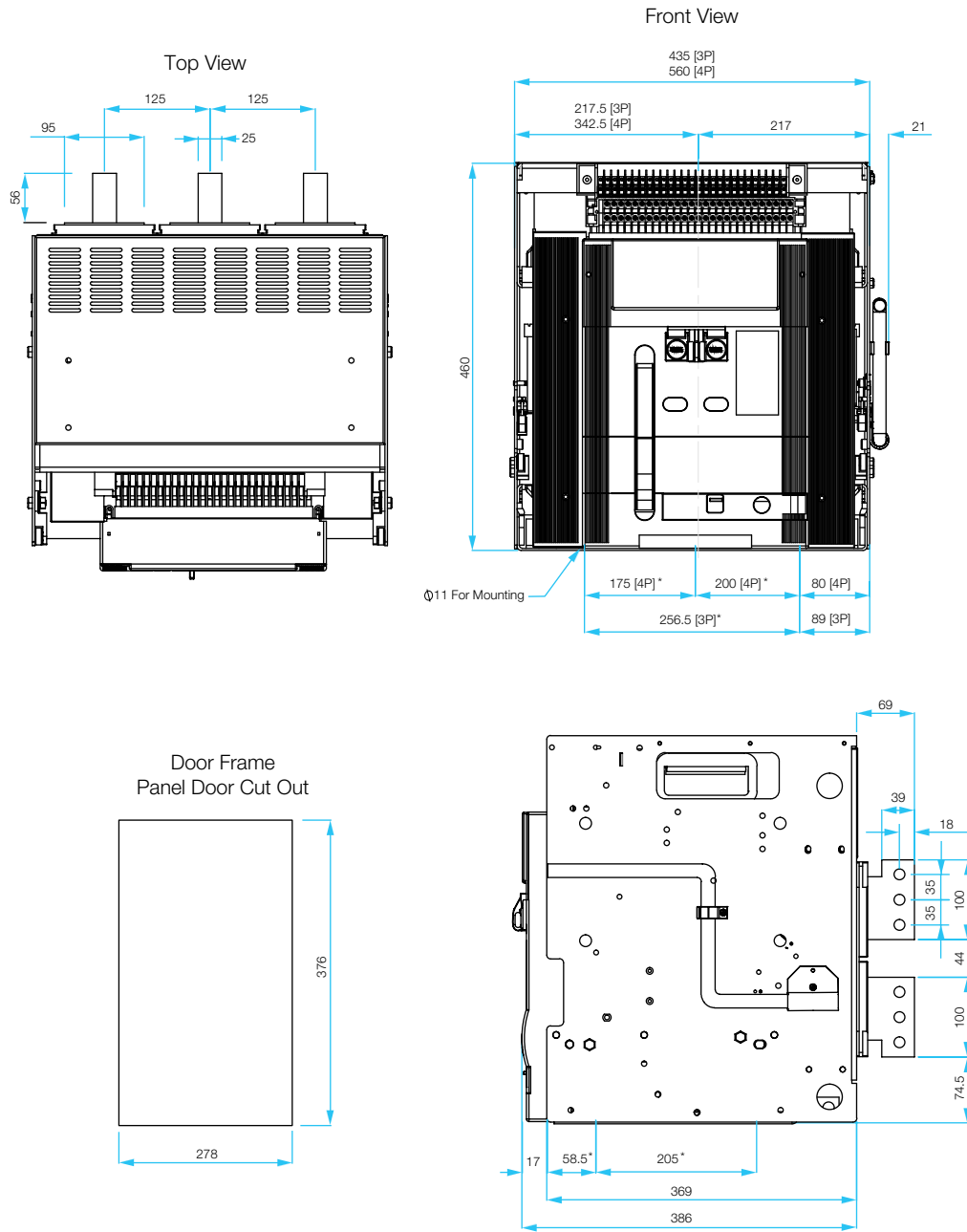

* Mounting hole dimensions
All dimensions are in mm.

Out Line Dimensions, Mounting Detail & Terminal Arrangement

Rating: 3200A to 4000A (V Series) Fixed Type

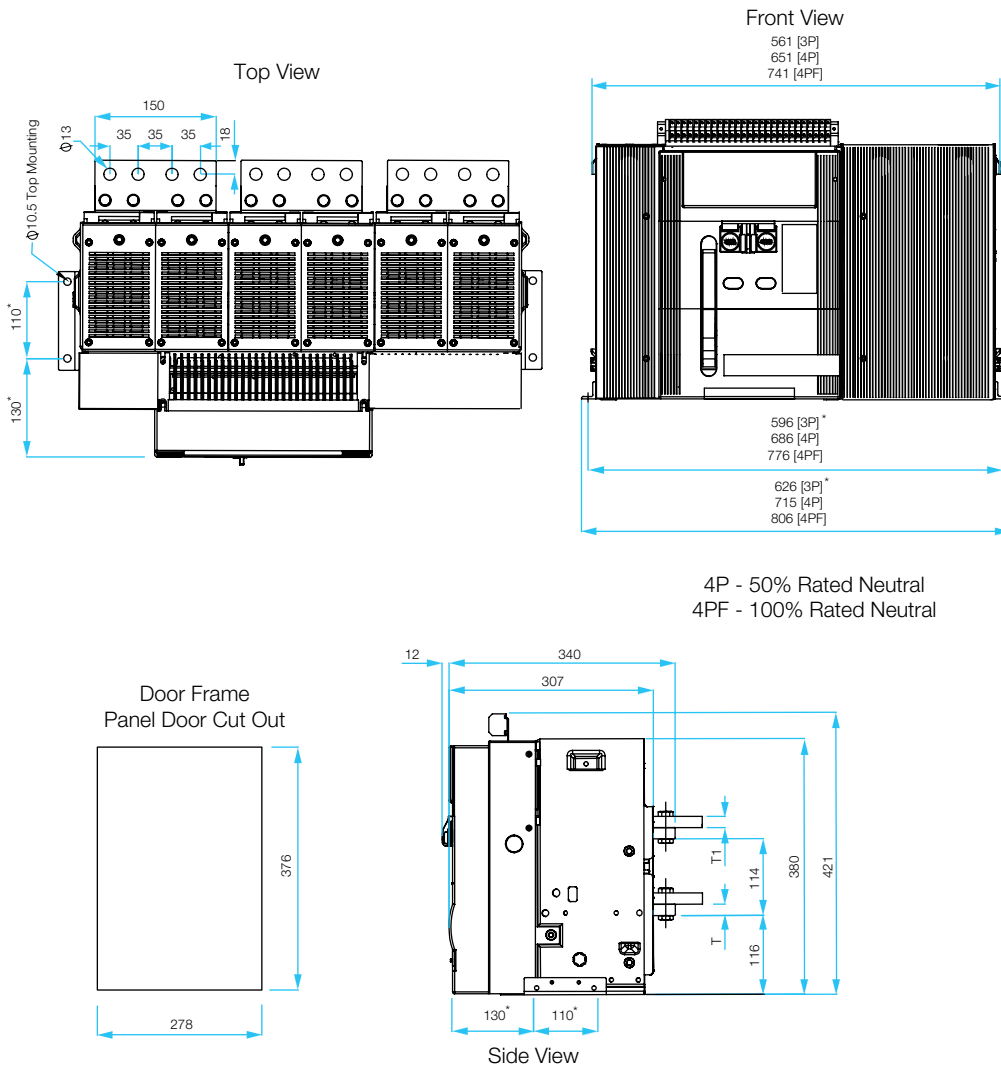

4P - 50% Rated Neutral
4PF - 100% Rated Neutral

* Mounting hole dimensions
All dimensions are in mm.

Thickness - 'T'	
Rating	'T'
3200A	20mm.
4000A	25mm.

Out Line Dimensions, Mounting Detail & Terminal Arrangement

Rating: 3200A to 4000A (V Series) Drawout Type

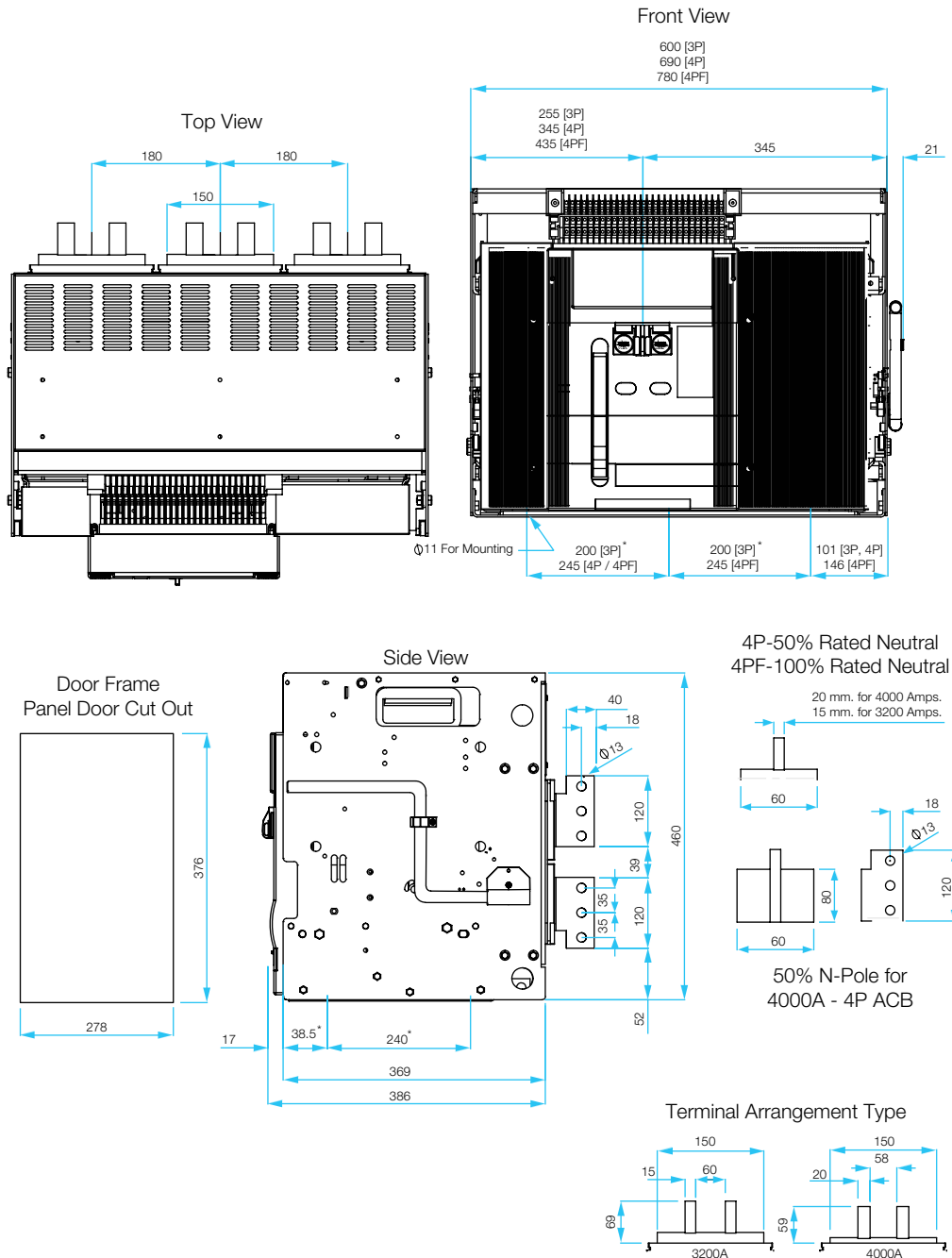

* Mounting hole dimensions
All dimensions are in mm.

Selection Chart

ACB Rating (Amp.) →

Performance Series →

Number of Poles →

Type of Mounting →

Type of Spring Charging →

Type of Protection →

Type of Tripping →

Other Accessories →

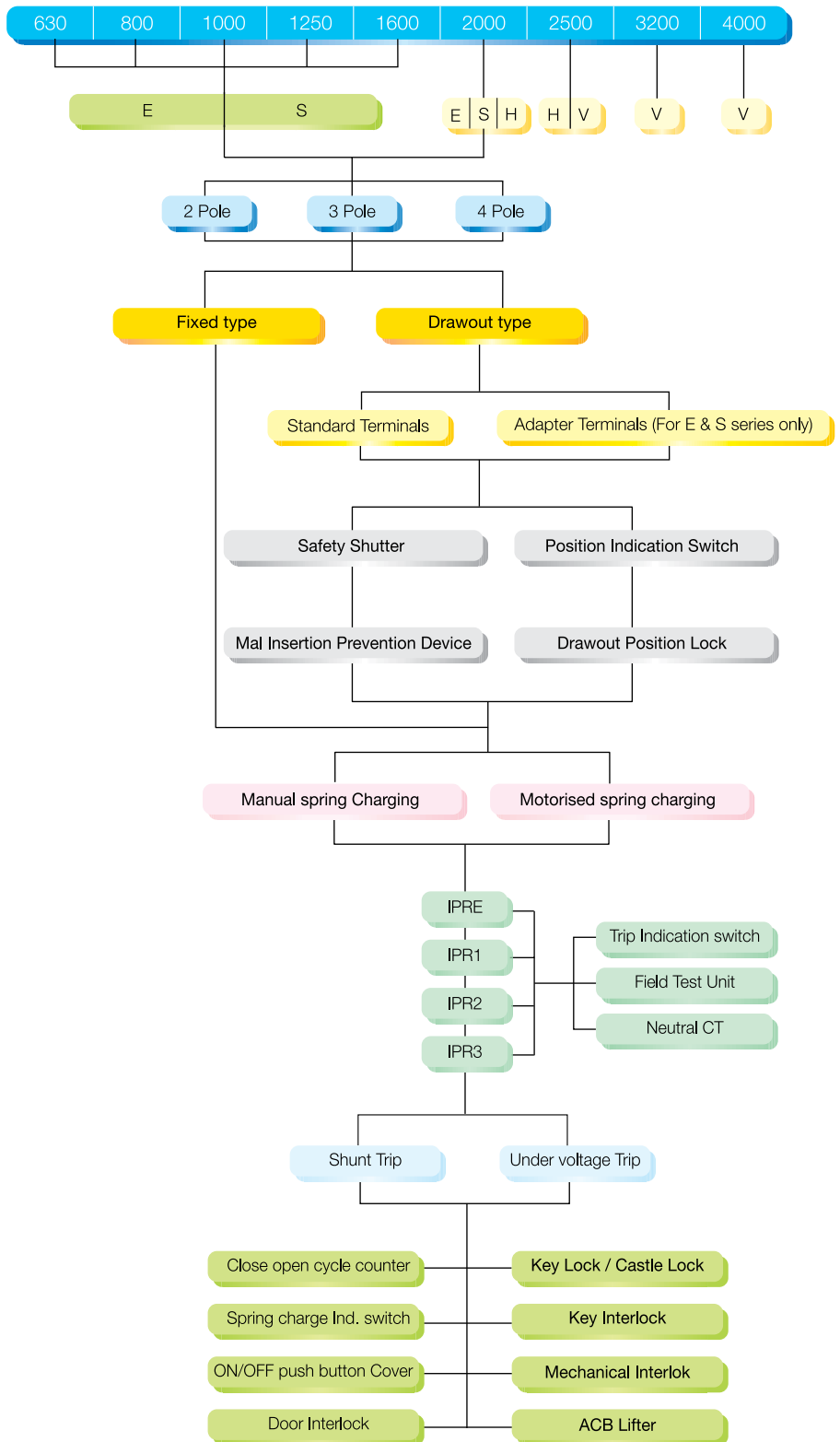

Order Form

Please check in front of appropriate box. Fill separate sheet for each type of ACB

CUSTOMER/ DEALER NAME		ORDER NO./DATE		END USER NAME		
Rating of ACB		630A <input type="checkbox"/>	1000A <input type="checkbox"/>	1600A <input type="checkbox"/>	2500A <input type="checkbox"/>	Qty.
		800A <input type="checkbox"/>	1250A <input type="checkbox"/>	2000A <input type="checkbox"/>	3200A <input type="checkbox"/>	
Series		E <input type="checkbox"/>	S <input type="checkbox"/>	H <input type="checkbox"/>	V <input type="checkbox"/>	
No. of Poles		2 <input type="checkbox"/>	3 <input type="checkbox"/>	4 <input type="checkbox"/>	4 <input type="checkbox"/>	
				(100% Neutral)	(50% Neutral for V-Series only)	
Mounting		Fixed <input type="checkbox"/>	Drawout <input type="checkbox"/>	* Horizontal Terminals (H,V) <input type="checkbox"/>		
				Adaptor Terminals (for E & S series only) <input type="checkbox"/>		
		* For E & S series - Horizontal terminals are standard, for H & V series vertical terminals are standard. Please specify if other combination is required.				
Spring Charging Operation		Manual <input type="checkbox"/>	Electrical <input type="checkbox"/>	Closing Coil _____ VAC/DC		
				Tripping Coil _____ VAC/DC		
				Motor _____ V		
Release		<input type="checkbox"/>	<input type="checkbox"/>	<input type="checkbox"/>	<input type="checkbox"/>	<input type="checkbox"/>
		Without Release	IPR E	IPR 1	IPR 2	IPR 3
		CT Rating _____ A,		Neutral CT <input type="checkbox"/>		
		Setting: O/L _____ A,		S/C _____ A,		
		Inst. _____ A,		GFT _____ A,		
Note: Unless otherwise specified O/L will be set at maximum value and all other settings would be set at mid values.						
Other Accessories		Close open cycle counter <input type="checkbox"/>	Field test unit <input type="checkbox"/>	Position Indication Switch <input type="checkbox"/>	Spring Charge Indication Switch <input type="checkbox"/>	Mechanical Interlock <input type="checkbox"/>
		Mal Insertion Prevention device <input type="checkbox"/>	Door Interlock <input type="checkbox"/>	Five c/o additional Aux. contacts <input type="checkbox"/>	Shunt Trip Coil <input type="checkbox"/>	UVT <input type="checkbox"/>V
				Trip Indication Switch <input type="checkbox"/>	Key Lock <input type="checkbox"/>	
				Key Interlock	2L+1K <input type="checkbox"/>	3L+2K <input type="checkbox"/>

Note :

- Please specify the voltages for closing coil, shunt trip coil and UVT, available voltages are 24VDC, 110VAC/DC, 220VAC/DC and 415V AC and for motor available voltages are 220V AC/DC and 110V AC/DC.
- For details of Over current release, please refer the technical catalogue.

Moulded Case Circuit Breaker

Features:

- Wide range : 15A to 1600A (AC)
- Compact dimensions
- Adjustable thermal setting (70-100%) I_n .
- Adjustable magnetic setting (5-10 times / 4-10 times) I_n .
- Suitable for use as switch disconnecter
- In 4PwSN version, neutral makes first and breaks last
- Push to trip button provision
- Uniform front escutcheon plate
- Positive dolly position indication
- Suitable for DC application upto 1600A
- Separate main and arcing contacts
- Wide range of accessories

Range :

15A to 1600A in 7 frame sizes in single pole, three pole and four pole with switched neutral execution.

Specification :

Conforms to IS / IEC: 60947-2

Load Line range of Moulded Case Circuit Breakers are designed and manufactured to world-class standards. Loadline series MCCBs provide overload and short-circuit protection for all applications. The thermal & magnetic elements, adjustable over a wide band, make these MCCBs ideal for any distribution application.



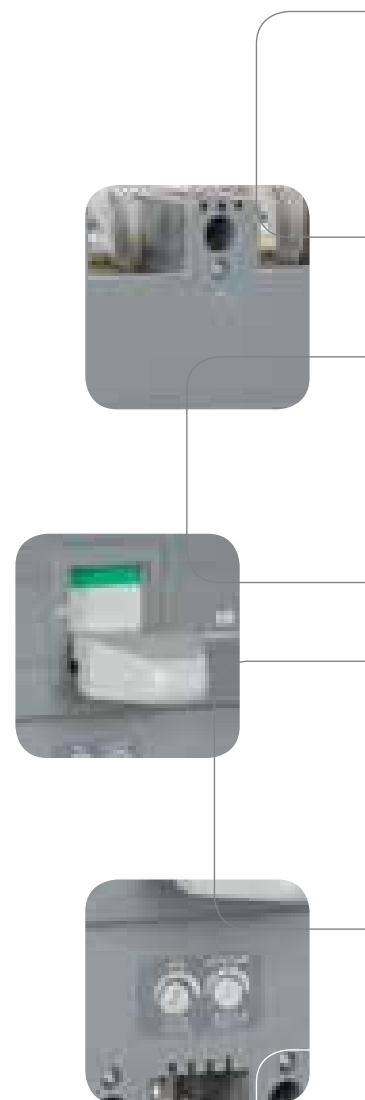
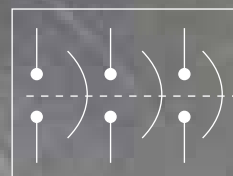

Loadline Moulded Case Circuit Breakers have precision formed moulded case and cover of high performance resin bonded thermoset material. The circuit breakers are designed to allow grouping in distribution panels or switchboards to present their operating handles and label escutcheons uniformly aligned in a single panel cut out.

The **switching mechanism** is Quick make-Quick break type and is tripfree, i.e. the breaker trips internally even if the operating knob is held in ON position.

The **contact mechanism** comprises of fixed and moving contacts made of sintered silver alloy for reliability, long life and anti-welding properties. Arcing contacts are provided in higher frames, further increasing the contact life.

The **arc extinguishing** device comprises of arc chutes having grid plates mounted in parallel between supports of insulating material. The arc is divided between these grid plates which helps in its fast quenching. The arc is thus confined, divided and extinguished in the arc chute. The excellent insulation between the conducting parts and better energy dissipation after short circuit makes it possible to make the load and line connections on either side.

The **tripping mechanism** comprises of a bimetal and heater element for overload protection and fixed & moving core for magnetic protection in each pole coupled to a single trip bar unit to avoid single phasing. The overload and magnetic setting are front adjustable on site.

Thermal Magnetic Type

The overload protection is provided by a combination of the heater element and the bimetal strip in each phase which activates the trip mechanism.

Short Circuit protection is provided by the magnetic circuit comprising of the fixed and moving core. In the event of short circuit, the moving core is attracted towards the fixed core due to the high electromagnetic forces developed which actuates the trip mechanism.

The fixed and moving contacts of Loadline MCCBs are so designed that an electromagnetic repulsive force is developed under high currents which is sufficient to overcome the spring tension holding the moving contacts, thereby initiating the contact opening resulting into faster opening of the contacts limiting the prospective short circuit current.



Technical Information

SH Frame

Ref. Standard	:	IS / IEC 60947-2
Rated operational Voltage	:	415V AC
Rated insulation Voltage	:	750V AC
Rated Impulse Voltage	:	8kV
Utilisation category	:	A
Rated frequency	:	50/60Hz
Operating altitude	:	2000 metres
Humidity	:	0 - 90%



Frame		SH 100		
		2P	3P	4P wSN
Number of Poles		2P	3P	4P wSN
Rated Current, I _n at 40° C	A	15 - 100*	15 - 100*	15 - 100*
Overload / Short Circuit Release		Fixed	Fixed	Fixed
Rated Ultimate Short Circuit Breaking Capacity (I _{cu}) (at different voltages)	kA			
240V	kA	25	25	25
415V	kA	10	10	10
440V	kA	10	10	10
500V	kA	7.5	7.5	7.5
Service Short Circuit Breaking Capacity (I _{cs})=% (I _{cu})	%	50	50	50
Weight	kg	0.45	0.65	0.85
Terminal Capacity(mm ²)	mm ²	35	35	35
Busbar Width(mm)	mm	15	15	15
Terminal screw size (15A - 50A) / (60A - 100A)		M5x12 / M8x12	M5x12 / M8x12	M5x12 / M8x12
Recommended Torque	Nm	2.5 / 10	2.5 / 10	2.5 / 10
Dimension (WxHxD)	mm	50x130x60	75x130x60	100x130x60
Internal Accessories				
Auxiliary Switch (1 C/O or 2C/O)			•	•
External Accessories				
Rotary Handel			•	•
Phase Barriers			+	+
Extended Terminals			•	•

* Current Ratings - 15A, 20A, 32A, 40A, 50A, 63A, 75A, 100A

+ Supplied with MCCB as standard

● Supplied with MCCB of rating 100A only

2P - Double Pole

3P - Three Pole

4PwSN - Four Pole with Switched Neutral

Technical Information

G-Frame

116

Standard conformity	:	IEC 60947-2/IS:13947-2
Rated operational voltage	:	500V AC
Rated Insulation Voltage	:	750V AC
Type of release	:	Thermomagnetic
Utilisation Category	:	A
Rated frequency	:	50/60 Hz
Ambient temp	:	40°C (50°C on request)
Operating altitude	:	2000 meters
Humidity	:	0 - 90%
Rated impulse voltage	:	8 KV



Frame		GS		GN		GH	
No. of Poles		1P	3P / 4PwSN	1P	3P / 4PwSN	1P	3P / 4PwSN
Standard current range / rating (I _n)A		16-160*	16-160*	16-160*	16-160*	16-160*	16-160*
Thermal release setting		Fixed	Fixed	Fixed	Fixed	Fixed	Fixed
Magnetic release setting for current rating :							
16A - 32A	A	350	350	350	350	350	350
40A - 50A	A	500	500	500	500	500	500
63A - 80A	A	800	800	800	800	800	800
100A - 160A	A	1000	1000	1000	1000	1000	1000
Rated short circuit making capacity (Peak) I _{cm} at 415V AC	KA	17 [†]	17	32 [†]	32	52.5 [†]	52.5
Rated ultimate short circuit breaking capacity (I _{cu}), KA	240V	10	16	16	25	25	40
(at different voltages)	415V	-	10	-	16	-	25
	440V	-	10	-	14	-	16
	500V	-	7.5	-	10	-	12
I _{cs} = % I _{cu}	%	100%	100%	75%	75%	75%	75%
Weight	SP	Kg	0.35	0.35	0.35	0.35	0.35
	TP	Kg	-	0.93	-	0.93	-
	4PwSN	Kg	-	1.2	-	1.2	-
Terminal capacity (cable)	Sq.mm	70	70	70	70	70	70
Bus bar (width)	mm	10	10	10	10	10	10
Recommended Torque	Nm	2.5	2.5	2.5	2.5	2.5	2.5
Internal Accessories							
Alarm Switch		-	•	-	•	-	•
Auxiliary Switch (1 C/O or 2C/O)		-	•	-	•	-	•
Shunt Trip		-	•	-	•	-	•
Under Voltage Release		-	•	-	•	-	•
External Accessories							
Earth Fault Relay		-	•	-	•	-	•
Rotary Handle - Direct, Extended		-	•	-	•	-	•
Back Studs		-	-	-	-	-	-
Extended Terminals (above 63A)		+	+	+	+	+	+
Dolly Extension		-	-	-	-	-	-
Phase Barriers		+	+	+	+	+	+
Terminal Shrouds		-	•	-	•	-	•
Dolly pad locking Device		-	•	-	•	-	•

* Current Ratings - 16A, 20A, 25A, 32A, 40A, 50A, 63A, 80A, 100A, 125A, 150A, 160A

• Available, - Not Available, + Supplied alongwith the MCCB as standard.

Δ Available in single pole

† At 240V

1P - Single Pole

3P - Three Pole

4PwSN - Four Pole with Switched Neutral

Technical Information

AA-Frame

117

Standard conformity	:	IEC 60947-2/IS:13947-2
Rated operational voltage	:	500V AC
Rated Insulation Voltage	:	750V AC
Type of release	:	Thermomagnetic
Utilisation Category	:	A
Rated frequency	:	50/60 Hz
Ambient temp	:	40°C (50°C on request)
Operating altitude	:	2000 meters
Humidity	:	0 - 90%
Rated impulse voltage	:	8 KV



Frame	AAS				AAN		
		1P	3P / 4PwSN	3P / 4PwSN	1P	3P / 4PwSN	3P / 4PwSN
No. of Poles		1P	3P / 4PwSN	3P / 4PwSN	1P	3P / 4PwSN	3P / 4PwSN
Standard current range / ratings (I _n)	A	25-125	25-125	160-200	160-250	25-125	160-250
Thermal release setting (Adjustable)		70-100% of I _n			70-100% of I _n		
Magnetic release setting for current rating :							
25A - 63A		400A	400A	400A	400A	400A	400A
80A - 125A		800A	800A	800A	800A	800A	800A
160A - 250A		1600A	1600A	1600A	1600A	1600A	1600A
50A - 125A AM Frame		-	-	-	-	-	-
160A - 250A AM Frame		-	-	-	-	-	-
Rated short circuit making capacity (Peak) I _{cm}	KA	52.5 [†]	52.5	32	52.5 [†]	73.5	52.5
Rated ultimate short circuit breaking capacity (I _{cu}), KA	240V	25	40	25	25	50	40
(at different voltages)	415V	-	25	16	-	35	25
	440V	-	25	16	-	35	25
	500V	-	18	12	-	25	18
I _{cs} = % I _{cu}	%	75%	75%	100%	75%	75%	75%
Weight							
SP (Single Pole)	Kg	0.7	-	-	0.7	-	-
TP (Triple Pole)	Kg	-	1.8	1.8	-	1.8	1.8
FPwSN (Four Pole Switched Neutral)	Kg	-	2.4	2.4	-	2.4	2.4
Terminal capacity (Cable)	Sq.mm	70 (upto 100A)/150 (125A-250A)			70 (upto 100A)/150 (125A-250A)		
(Bus bar width)	mm	25 (125A-250A)			25 (125A-250A)		
Recommended Torque	Nm	10	10	10	10	10	10
Internal Accessories							
Auxiliary Switch (1 C/O or 2C/O)		-	•	•	-	•	•
Shunt Trip		-	•	•	-	•	•
Under Voltage Release		-	•	•	-	•	•
Alarm Switch (1 C/O)		-	•	•	-	•	•
External Accessories							
Earth Fault Relay		-	•	•	-	•	•
Rotary Handle - Direct, Extended		-	•	•	-	•	•
Back Studs		-	•	•	-	•	•
Extended Terminals (80A & Above)		+	+	+	+	+	+
Dolly Extension		-	-	-	-	-	-
Phase Barriers		+	+	+	+	+	+
Terminal Shrouds		•	•	•	•	•	•
Dolly pad locking Device		•	•	•	•	•	•

* Current Ratings - 25A, 32A, 40A, 50A, 63A, 80A, 100A, 125A, 160A, 200A, 250A

• Available, - Not Available, + Supplied alongwith the MCCB above 63A

† At 240V

1P - Single Pole

3P - Three Pole

4PwSN - Four Pole with Switched Neutral

Technical Information

F-Frame

118

Standard conformity	:	IEC 60947-2/IS:13947-2
Rated operational voltage	:	500V AC
Rated Insulation Voltage	:	750V AC
Type of release	:	Thermomagnetic
Utilisation Category	:	A
Rated frequency	:	50/60 Hz
Ambient temp	:	40°C (55°C on request)
Operating altitude	:	2000 meters
Humidity	:	0 - 90%
Rated impulse voltage	:	8 KV



Frame		FN	FH
No. of Poles		3P / 4PwSN	3P / 4PwSN
Standard Current ratings (I _n)	A	25-250*	25-250*
Thermal release setting		Fixed	Fixed
Magnetic release setting for current rating		Fixed	Fixed
25A - 32A		500A	500A
40A - 80A		800A	800A
100A - 125A		1250A	1250A
160A - 250A		1600A	1600A
Rated short circuit making capacity (Peak) I _{cm} kA		73.5	105
Rated ultimate short circuit breaking capacity(I _{cu}), kA	240V	50	70
(at different voltages)	380V	35	50
	415V	35	50
	500V	25	35
I _{cs} = % I _{cu}	%	100%	100%
Weight TP (Triple Pole) / FPwSN	Kg	2.9 / 3.8	2.9 / 3.8
Terminal Type		M8	M8
Terminal capacity (Cable)	Sq.mm	185	185
(Bus bar width)	mm	18	18
Internal Accessories			
Auxiliary Switch (1 C/O or 2C/O)		•	•
Shunt Trip		•	•
Under Voltage Release		•	•
Alarm Switch (1 C/O)		•	•
External Accessories			
Earth Fault Relay		•	•
Rotary Handle - Extended		•	•
Back Studs		•	•
Extended Terminals (80A & Above)		+	+
Dolly Extension		-	-
Phase Barriers		+	+
Terminal Shrouds (only in 3P MCCB)		•	•
Dolly pad locking Device		•	•

* Current Ratings - 25A, 32A, 40A, 50A, 63A, 80A, 100A, 125A, 160A, 200A, 250A

• Available, - Not Available, + Supplied alongwith the MCCB above 63A.

Factory Fitted

3P - Three Pole

4PwSN - Four Pole with Switched Neutral

Technical Information

L-Frame

119

Ref. Standard	:	IS / IEC 60947-2
Rated operational Voltage	:	415V AC
Rated insulation Voltage	:	750V AC
Rated impulse Voltage	:	8kV
Type of Release	:	Thermal Magnetic
Utilisation category	:	A
Rated frequency	:	50 / 60Hz
Operating altitude	:	2000 metres
Humidity	:	0 - 90%
Suitability of Isolation	:	Yes



Frame		LS	LN
No. of Poles		3P / 4P wSN	3P / 4P wSN
Standard Current Ratings (I_n)	A	250, 320, 400, 500, 630	250, 320, 400, 500, 630
Thermal release setting (Adjustable)		80-100% I_n	80-100% I_n
Magnetic release setting (Fixed)			
250 A - 400 A		4000 A	4000 A
500 A - 630 A		6300 A	6300 A
Magnetic release setting (Adjustable)			
250 A - 400 A		2000 A - 4000 A	2000 A - 4000 A
500 A - 630 A		2500 A - 6300 A	2500 A - 6300 A
Rated S.C. Making Capacity at 415 V (I _{cm})	kA	75.6	105
Rated Ultimate S.C breaking capacity (I _{cu}) at			
240 V	kA	50	65
415 V	kA	36	50
500 V	kA	25	35
Rated Service S.C Breaking Capacity at 415 V	I _{cs} = % I _{cu}	100%	75%
Weight			
Three Pole (3P)	Kg	5.6	5.6
Four Pole with Switched Neutral (4P wSN)	Kg	7	7
Terminal capacity (Max.)	Sq. mm	1 x 240 (250 A-400 A) 2 x 185 (500 A-630 A)	1 x 240 (250 A-400 A) 2 x 185 (500 A-630 A)
Bus bar width	mm	30	30
Overall dimension			
Three Pole (3P)	(W x H x D)	140 x 254 x 110	140 x 254 x 110
Four Pole with Switched Neutral (4P wSN)	(W x H x D)	186 x 254 x 110	186 x 254 x 110
Internal Accessories #			
Auxillary Switch	1C/O or 2C/O	•	•
Shunt Trip (built-in auxillary switch)		•	•
Under Voltage Release		•	•
Alarm Switch		•	•
External Accessories			
Rotary Handle - Extended		•	•
Extended Terminals		•	•
Terminal Shroud		•	•
Phase Barriers		•	•
Dolly pad locking device		•	•
Earth Fault Relay		•	•

• Available

Only 2 accessories at a time can be fitted in the MCCB

3P - Three Pole

4P wSN - Four Pole with Switched Neutral

3P - Three Pole

Technical Information

CN / CH / DN - Frame

120

Standard conformity	:	IEC 60947-2/IS:13947-2
Rated operational voltage	:	500V AC
Rated Insulation Voltage	:	690V AC
Type of release	:	Thermomagnetic
Utilisation Category	:	A
Rated frequency	:	50/60 Hz
Ambient temp	:	40°C (50°C on request)
Operating altitude	:	2000 meters
Humidity	:	0 - 90%
Rated impulse voltage	:	8 KV

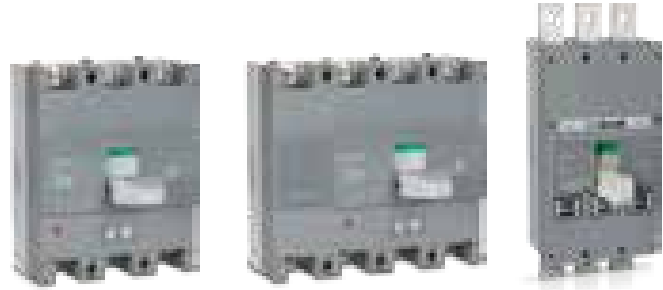

Frame		CN	CH	DN
No. of Poles		3P/4PwSN	3P/4PwSN	3P/4PwSN
Standard current ratings (I _n)	A	160-800*	160-800*	1000-1600*
Thermal release setting (Adjustable)		70-100% of I _n	70-100% of I _n	70-100% of I _n
Magnetic release setting		Adjustable	Adjustable	Adjustable
160 - 315A CN/CH Frame		5-10 times I _n	5-10 times I _n	-
400 - 800A CN/CH Frame		4-10 times I _n	4-10 times I _n	-
800 - 1600A DN Frame		-	-	4000-10,000A
Rated short circuit making capacity (Peak) I _{cm}	KA	73.5	105	105
Rated ultimate short circuit breaking capacity(I _{cu}), KA (at different voltages)	240V 380V 415V 500V	50 35 35 25	70 50 50 35	70 50 50 35
I _{cs} = % I _{cu}	%	75%	50%	75%
Weight TP (Triple Pole)	Kg	9.2	9.2	17#/19**
FPwSN (Four Pole with Switched Neutral)	Kg	11.6	11.6	22/25
Terminal capacity (Cable)	Sq.mm	-	-	-
(Busbar width)	mm	40	40	45** upto 1000A 60** upto 1250A 65** upto 1600A 35.5# upto 1600A
Internal Accessories				
Auxiliary Switch (1 C/O or 2 C/O)		•	•	•
Shunt Trip		•	•	•
Under Voltage Release		•	•	•
Alarm Switch (1 C/O) # Factory Filled		•	•	•
External Accessories				
Earth Fault Relay		•	•	•
Rotary Handle - Extended		•	•	•
Back Studs		•	-	•
Extended Terminals		+	•	•
Dolly Extension		•	•	•
Phase Barriers		+	-	•
Terminal Shrouds		-	-	-
Dolly pad locking Device		•	•	•

* Current Ratings - 160A, 200A, 250A, 315A, 400A, 500A, 630A, 800A, 1000A, 1250A, 1600A.

• Available, - Not Available, + Supplied alongwith the MCCB as standard.

** Terminals at Front

Terminals at back / rear

3P - Three Pole

4PwSN - Four Pole with Switched Neutral

Technical Information (DC MCCBs)

GN / AN / CH / DN - Frame

DC MCCBs					
Standard conformity	: IEC 60947-2/IS:13947-2				
Rated operational voltage	: 250V DC				
Rated Insulation Voltage	: 690V AC				
Type of release	: Thermomagnetic				
Utilisation Category	: A				
Ambient temp	: 40°C				
Operating altitude	: 2000 meters				
Humidity	: 0-90%				
					
Frame		GN	AAN	CH	DN
No. of Poles		3P	3P	3P	3P
Standard current ratings I_n	A	25-125*	160-250*	160-800*	1000-1600*
Thermal release setting		Fixed	Adjustable (70-100% of I_n)	Adjustable (70-100% of I_n)	Adjustable (70-100% of I_n)
Magnetic release setting for current rating :					
25-50A	GN Frame	500A	-	-	-
63-80A	GN Frame	800A	-	-	-
100-125A	GN Frame	1000A	-	-	-
160-200A	AN Frame	-	1600A	-	-
160-315A	CH Frame	-	-	5 - 10 times I_n	-
400-800A	CH Frame	-	-	4 - 10 times I_n	-
800-1600A	DN Frame	-	-	-	4000-10,000A
Rated ultimate short circuit breaking capacity (I_{cu}), at 250V DC	KA	5	10	20	20
$I_{cs} = \% I_{cu}$	%	75%	75%	50%	75%
Weight	Kg	0.93	1.8	9.2	17#/19**
Terminal capacity (Cable) (Busbar width)	Sq.mm mm	70 10	70(upto 100A)/150 (125A-250A) 25	- 40	- 45** upto 1000A 60** upto 1250A 65** upto 1600A 35.5# upto 1600A
Recommended Torque	Nm	2.5	10	-	-
Internal Accessories					
Auxiliary Switch (1 C/O or 2 C/O)		•	•	•	•
Shunt Trip		•	•	•	•
External Accessories					
Earth Fault Relay		•	•	•	•
Rotary Handle		•	•	•	•
Back Studs		-	•	•	•
Extended Terminals		+	+	+	+
Dolly Extension		-	-	+	+
Phase Barriers		+	+	+	+
Terminal Shrouds		•	•	-	-
Dolly pad locking Device		•	•	•	•

* Current Ratings - 25A, 32A, 40A, 50A, 63A, 80A, 100A, 125A, 160A, 200A, 250A, 315A, 400A, 500A, 630A, 800A, 1000A, 1250A, 1600A.

• Available, - Not Available, + Supplied alongwith the MCCB as standard. ** Terminals at Front, # Terminals at Rear.

Loadline DC MCCBs

DC MCCBs are available in three pole version from 25A-1600A with breaking capacity of 5KA, 10KA & 20KA.

The selection of the circuit breaker for DC applications depends on these criteria :-

- Rated current of the equipment.
- Rated voltage, which determines the number of poles in series for breaking. For voltages upto 250V DC, two poles of the breaker are connected in series to form the positive pole and the third pole to be used as a negative pole or three poles can be used in series.
- The maximum short-circuit current at the point of installation, which determines the breaking capacity.
- The (L/R) ratio for the application should be ≤ 15 ms
- In D Frame Rear Terminals are available in place of Back Studs

SH Frame MCCBs

SH Frame MCCB



Current Rating (A)	Cat. No.		
	Double Pole	Three Pole	Four Pole wSN
15A	IHLSHAAD0015	IHLSHAAT0015	IHLSHAAF0015
20A	IHLSHAAD0020	IHLSHAAT0020	IHLSHAAF0020
30A	IHLSHAAD0030	IHLSHAAT0030	IHLSHAAF0030
40A	IHLSHAAD0040	IHLSHAAT0040	IHLSHAAF0040
50A	IHLSHAAD0050	IHLSHAAT0050	IHLSHAAF0050
60A	IHLSHAAD0060	IHLSHAAT0060	IHLSHAAF0060
75A*	IHLSHAAD0075	IHLSHAAT0075	IHLSHAAF0075
100A*	IHLSHAAD0100	IHLSHAAT0100	IHLSHAAF0100

* Extended Terminals supplied with MCCB of rating 100A only.

SH Frame Accessories

(Accessories are for 3P / 4P WSN)

Auxiliary Contact

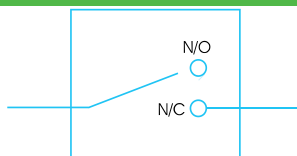

Auxiliary Contact (250Vac / 250Vdc) (450Vac / 250Vdc)

1. Change Over (1NO+1NC)	IHLA1CO
2. Change Over (2NO+2NC)	IHLA2CO

Rotary Handle



Description	Cat. No.
With Door interlock and 300mm remote shaft	IHLRN30

Dimension (in mm)

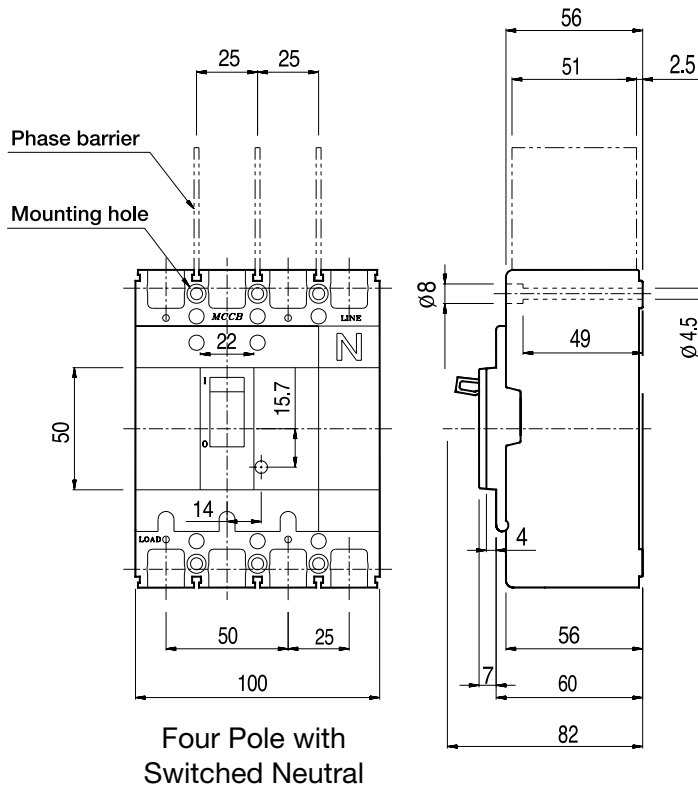
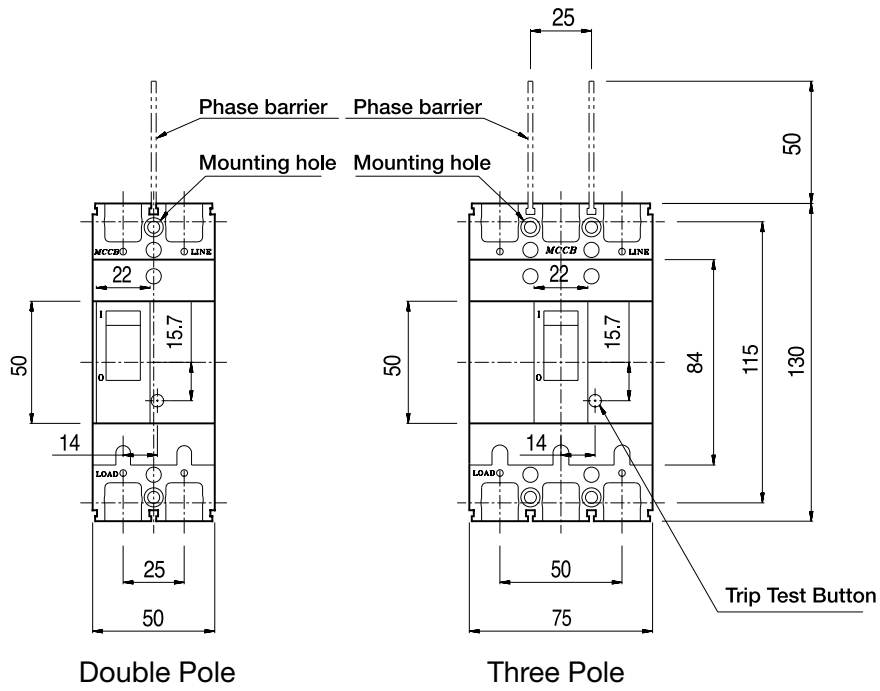

G Frame MCCBs



G Frame Single Pole MCCB			
Current Rating (A)	Icu 10kA at 240V Cat. No.	Icu 16kA at 240V Cat. No.	Icu 25kA at 240V Cat. No.
25	IHLGSS0025	IHLGNS0025	IHLGHDAS0025
32	IHLGSS0032	IHLGNS0032	IHLGHDAS0032
40	IHLGSS0040	IHLGNS0040	IHLGHDAS0040
50	IHLGSS0050	IHLGNS0050	IHLGHDAS0050
63	IHLGSS0063	IHLGNS0063	IHLGHDAS0063
80	IHLGSS0080	IHLGNS0080	IHLGHDAS0080
100	IHLGSS0100	IHLGNS0100	IHLGHDAS0100
125	IHLGSS0125	IHLGNS0125	IHLGHDAS0125
150	IHLGSS0150	IHLGNS0150	IHLGHDAS0150
160	IHLGSS0160	IHLGNS0160	IHLGHDAS0160



G Frame Three Pole MCCB			
Current Rating (A)	Icu 10kA at 415V Cat. No.	Icu 16kA at 415V Cat. No.	Icu 25kA at 415V Cat. No.
25	IHLGST0025	IHLGNT0025	IHLGHT0025
32	IHLGST0032	IHLGNT0032	IHLGHT0032
40	IHLGST0040	IHLGNT0040	IHLGHT0040
50	IHLGST0050	IHLGNT0050	IHLGHT0050
63	IHLGST0063	IHLGNT0063	IHLGHT0063
80	IHLGST0080	IHLGNT0080	IHLGHT0080
100	IHLGST0100	IHLGNT0100	IHLGHT0100
125	IHLGST0125	IHLGNT0125	IHLGHT0125
150	IHLGST0150	IHLGNT0150	IHLGHT0150
160	IHLGST0160	IHLGNT0160	IHLGHT0160



G Frame Four Pole wSN MCCB			
Current Rating (A)	Icu 10kA at 415V Cat. No.	Icu 16kA at 415V Cat. No.	Icu 25kA at 415V Cat. No.
25	IHLGSF0025	IHLGNF0025	IHLGHF0025
32	IHLGSF0032	IHLGNF0032	IHLGHF0032
40	IHLGSF0040	IHLGNF0040	IHLGHF0040
50	IHLGSF0050	IHLGNF0050	IHLGHF0050
63	IHLGSF0063	IHLGNF0063	IHLGHF0063
80	IHLGSF0080	IHLGNF0080	IHLGHF0080
100	IHLGSF0100	IHLGNF0100	IHLGHF0100
125	IHLGSF0125	IHLGNF0125	IHLGHF0125
150	IHLGSF0150	IHLGNF0150	IHLGHF0150
160	IHLGSF0160	IHLGNF0160	IHLGHF0160

G Frame Accessories

(Accessories are for 3P / 4P wSN)

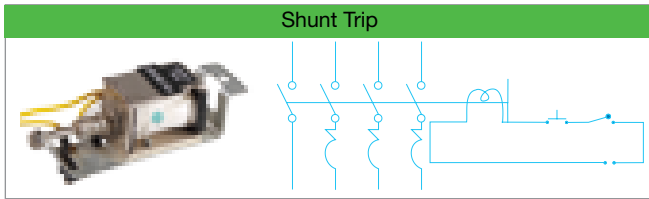

Voltage	Cat. No.
100-110Vac	IHLGS110
220-240Vac	IHLGS240
380-415Vac	IHLGS415

125

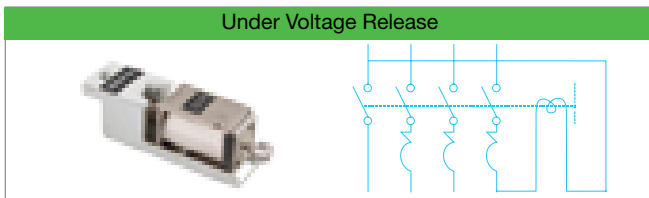

Voltage	Cat. No.
110-120 Vac	IHLGU110
220-240 Vac	IHLGU240
380-440 Vac	IHLGU440

The breaker trips if the supply voltage dips below 70% to 35% of the rated voltage.

The breaker cannot be switched ON unless there is a supply to the UVR. (NVNC feature).

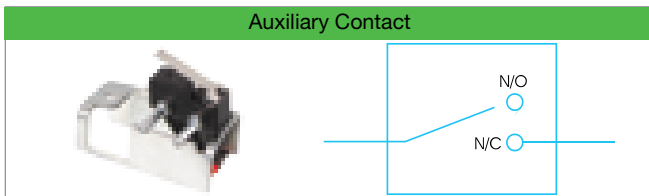

Auxiliary Contact (250Vac / 250Vdc) (450Vac / 250Vdc)

1. Change Over (1NO+1NC)	IHLASG1CO
2. Change Over (2NO+2NC)	IHLASG2CO

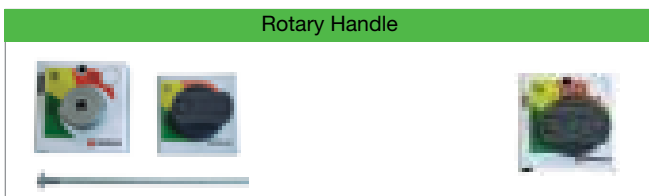

Description	Cat. No.
Direct Mounted	IHLGD000
With Door interlock and 300mm remote shaft	IHLGRN30

G Frame Accessories

(Accessories are for 3P / 4P WSN)

Other Accessories



		Cat. No.
Dolly Pad locking device		IHLDPG125
Phase Barriers	Three P	ISLGX0046
	Four P	ISLGX0048
Terminal Shrouds	Single P	IHLTSGS00
	Three P	IHLTSGT00
	Four P	IHLTSGF00
Extended terminals Up to 80 A	Single P	ISLGX0055
	Three P	ISLGX0056
	Four P	ISLGX0057
Extended terminals 100 A - 160 A	Single P	ISLGX0014
	Three P	ISLGX0012
	Four P	ISLGX0045

Dimensions (in mm)

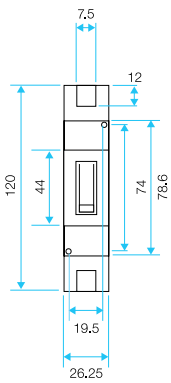

Single Pole

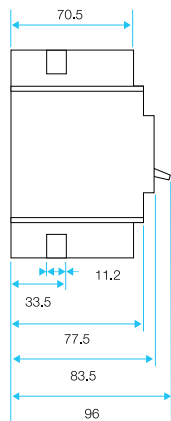

Three Pole

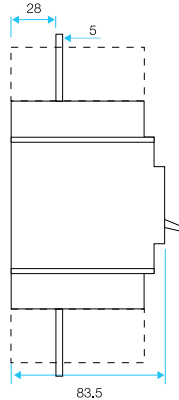
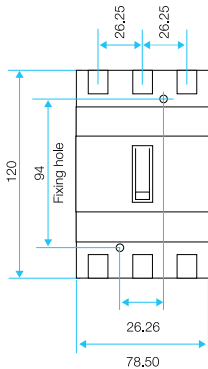

Three Pole with Extended Terminals

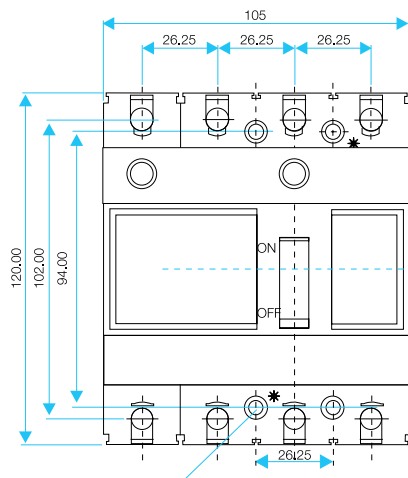
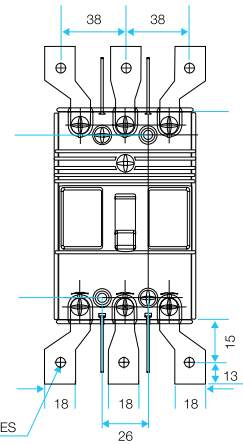

2 NOS. MOUNTING HOLES FOR M4 SCREWS

Four Pole with Switched Neutral

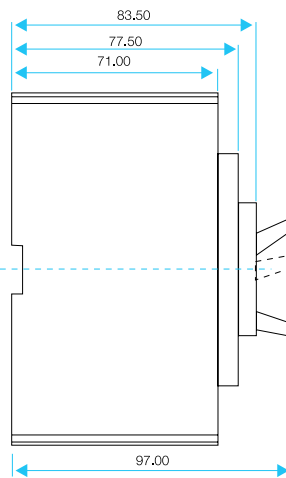

Dimensions (in mm) - Rotary Handle

Handle Fixing Details - 'G' Frame

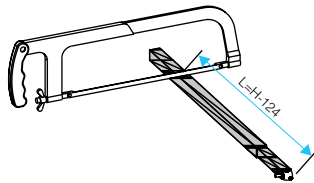
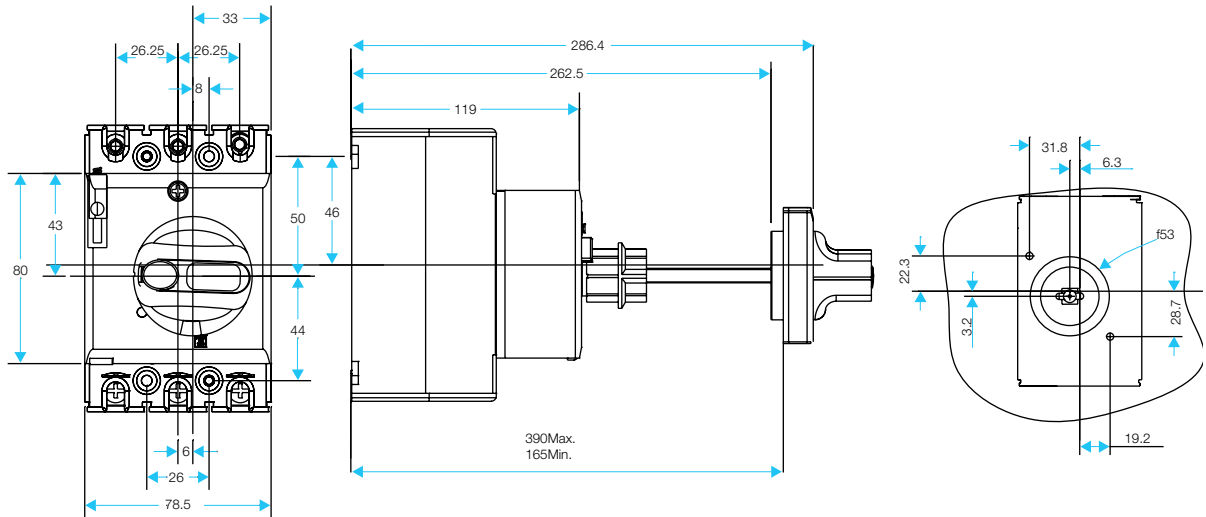

- I - MCCB ON
- O - MCCB OFF
- Trip - (In between I and O positions)
MCCB tripped by release or push to trip
- To re-close the MCCB move the handle towards position 'RESET' first till MCCB resets and then switch to position - 'I'.

Handle Fixing Details - 'A' Frame

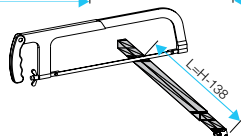
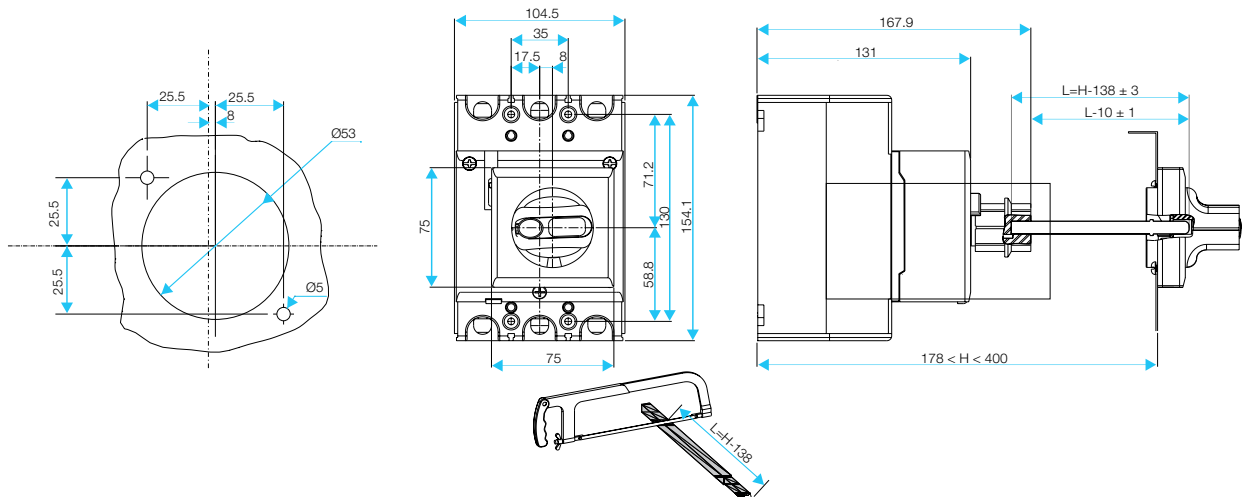

AA Frame MCCBs



AA Frame Single Pole MCCB	
Current Rating (A)	Icu 25kA at 240V Cat. No.
25	IHLASS0025
32	IHLASS0032
40	IHLASS0040
50	IHLASS0050
63	IHLASS0063
80	IHLASS0080
100	IHLASS0100
125	IHLASS0125
160	IHLANS0160
200	IHLANS0200
250	IHLANS0250



AA Frame Three Pole MCCB			
Current Rating (A)	Icu 16kA at 415V Cat. No.	Icu 25kA at 415V Cat. No.	Icu 35kA at 415V Cat. No.
25	--	IHLAST0025	IHLANT0025
32	--	IHLAST0032	IHLANT0032
40	--	IHLAST0040	IHLANT0040
50	--	IHLAST0050	IHLANT0050
63	--	IHLAST0063	IHLANT0063
80	--	IHLAST0080	IHLANT0080
100	--	IHLAST0100	IHLANT0100
125	--	IHLAST0125	IHLANT0125
160	IHLAST0160	IHLANT0160	--
200	IHLAST0200	IHLANT0200	--
250	--	IHLANT0250	--



AA Frame Four Pole wSN MCCB			
Current Rating (A)	Icu 16kA at 415V Cat. No.	Icu 25kA at 415V Cat. No.	Icu 35kA at 415V Cat. No.
25	--	IHLASF0025	IHLANF0025
32	--	IHLASF0032	IHLANF0032
40	--	IHLASF0040	IHLANF0040
50	--	IHLASF0050	IHLANF0050
63	--	IHLASF0063	IHLANF0063
80	--	IHLASF0080	IHLANF0080
100	--	IHLASF0100	IHLANF0100
125	--	IHLASF0125	IHLANF0125
160	IHLASF0160	IHLANF0160	--
200	IHLASF0200	IHLANF0200	--
250	--	IHLANF0250	--

AA Frame Accessories

(Accessories are for 3P / 4P wSN)

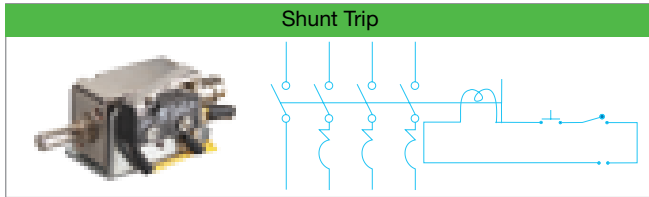

Voltage	Cat. No.
100-110Vac	IHLAS110
220-240Vac	IHLAS240
380-415 Vac	IHLAS415

129

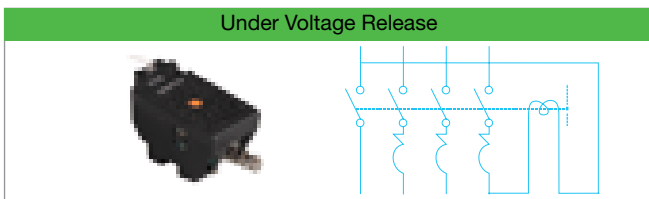

Voltage	Cat. No.
110-120 Vac	IHLAU110
220-240 Vac	IHLAU240
380-440 Vac	IHLAU440

The breaker trips if the supply voltage dips below 70% to 35% of the rated voltage.

The breaker cannot be switched ON unless there is a supply to the UVR. (NVNC feature).

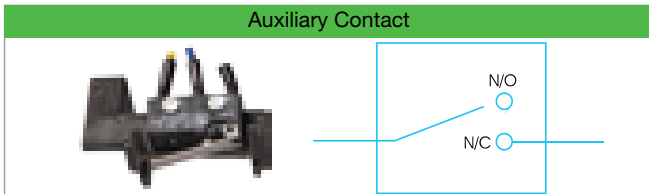

Auxiliary Contact (250Vac / 250Vdc) (450Vac / 250Vdc)	
1. Change Over (1NO+1NC)	IHLAA1CO
2. Change Over (2NO+2NC)	IHLAA2CO

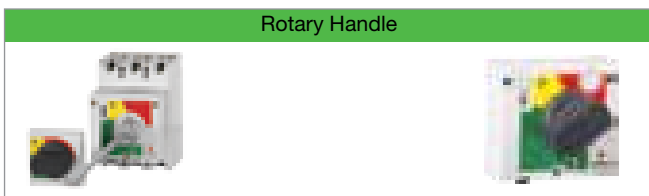

Description	Cat. No.
Direct Mounted	IHLAD000
With Door interlock and 300mm remote shaft	IHLARN30

AA Frame Accessories

(Accessories are for 3P / 4P wSN)

Back Studs



	Cat. No.
Back studs (Upto 250A)	IHLLBSA250

Other Accessories



		Cat. No.
Dolly Pad locking device		IHLLDPA250
Phase Barriers	Three Pole	ISLAX0063
	Four Pole	ISLAX0064
Terminal Shrouds	Single Pole	IHLLTSAS00
	Three Pole	IHLLTSAT00
	Four Pole	IHLLTSAF00
Extended terminals Up to 100 A	Single Pole	ISLAX0056
	Three Pole	ISLAX0057
	Four Pole	ISLAX0058
Extended terminals 125 A - 250 A	Single Pole	ISLAX0048
	Three Pole	ISLAX0061
	Four Pole	ISLAX0059

Dimensions (in mm)

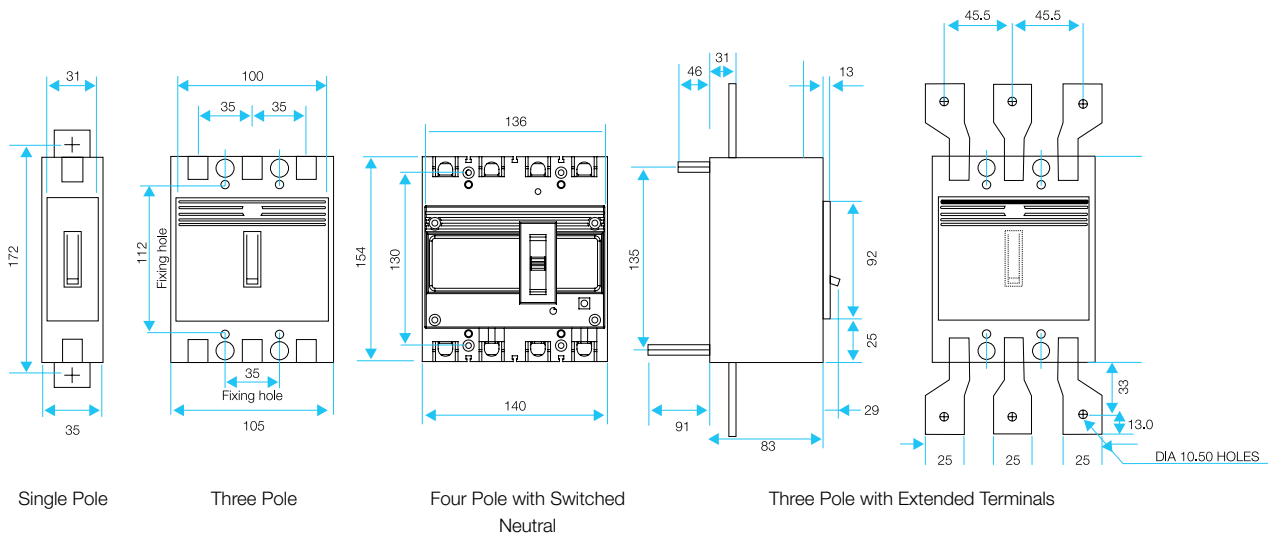

FN/FH Frame MCCBs



FN/FH Frame Three Pole / Four Pole with Switch Neutral				
Current Rating (A)	Icu 35kA at 415V Cat. No.	Icu 50kA at 415V Cat. No.	Icu 35kA at 415V Cat. No.	Icu 50kA at 415V Cat. No.
	Three Pole		Four Pole	
25	IHLFNT0025	IHLFHT0025	IHLFNF0025	IHLFHF0025
32	IHLFNT0032	IHLFHT0032	IHLFNF0032	IHLFHF0032
40	IHLFNT0040	IHLFHT0040	IHLFNF0040	IHLFHF0040
50	IHLFNT0050	IHLFHT0050	IHLFNF0050	IHLFHF0050
63	IHLFNT0063	IHLFHT0063	IHLFNF0063	IHLFHF0063
80	IHLFNT0080	IHLFHT0080	IHLFNF0080	IHLFHF0080
100	IHLFNT0100	IHLFHT0100	IHLFNF0100	IHLFHF0100
125	IHLFNT0125	IHLFHT0125	IHLFNF0125	IHLFHF0125
160	IHLFNT0160	IHLFHT0160	IHLFNF0160	IHLFHF0160
200	IHLFNT0200	IHLFHT0200	IHLFNF0200	IHLFHF0200
250	IHLFNT0250	IHLFHT0250	IHLFNF0250	IHLFHF0250

FN/FH Frame Accessories

(Accessories are for 3P / 4P wSN)

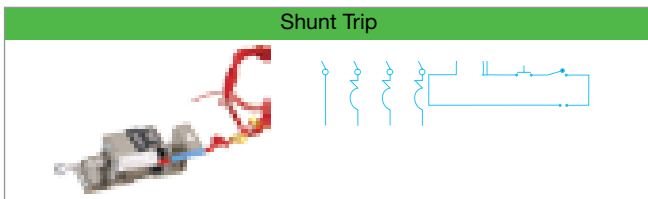

Voltage	Cat. No.
100-110Vac	IHLLSTF110
220-240Vac	IHLLSTF240
380-415 Vac	IHLLSTF415

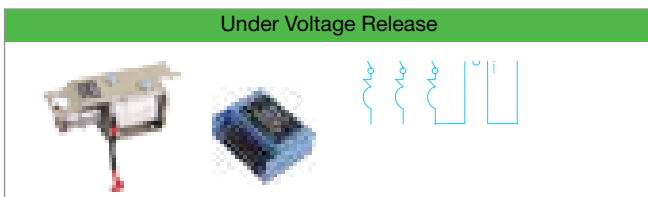

Voltage	Cat. No.
110-120 Vac	IHLUVRF110
220-240 Vac	IHLUVRF240
380-440 Vac	IHLUVRF440

The breaker trips if the supply voltage dips below 70% to 35% of the rated voltage.

The breaker cannot be switched ON unless there is a supply to the UVR. (NVNC feature).

Supplied with external mounting Power pack to operate on AC supplies. Additional transformer is supplied with ILUVRF440 & ILUVRF110.

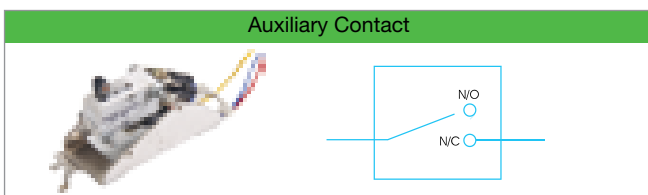

Auxiliary Contact (250Vac / 250Vdc) (450Vac / 250Vdc)	
1. Change Over (1NO+1NC)	IHLLASF1CO
2. Change Over (2NO+2NC)	IHLLASF2CO

FN/FH Frame Accessories

(Accessories are for 3P / 4P wSN)

Rotary Handle

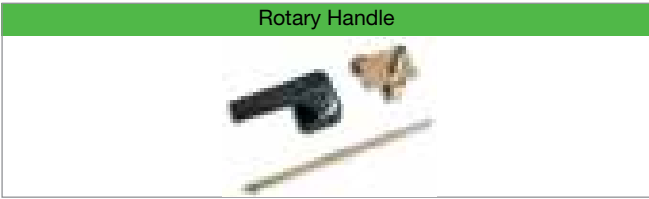

	Cat No.
With Door interlock and 300mm remote shaft	IHLRRHF30

Other Accessories



		Cat. No.
Dolly Pad locking device		IHLDPF250
Phase Barriers	Three Pole	ISSLFX0036
	Four Pole	ISSLFX0038
Terminal Shrouds	Three Pole	IHLTSFT00
	Four Pole	IHLTSFF00
Extended terminals Up to 100 A	Three Pole	ISLFX0047
	Four Pole	ISLFX0044
Extended terminals 125 A - 250 A	Three Pole	ISLFX0049
	Four Pole	ISLFX0046

Dimensions (in mm)

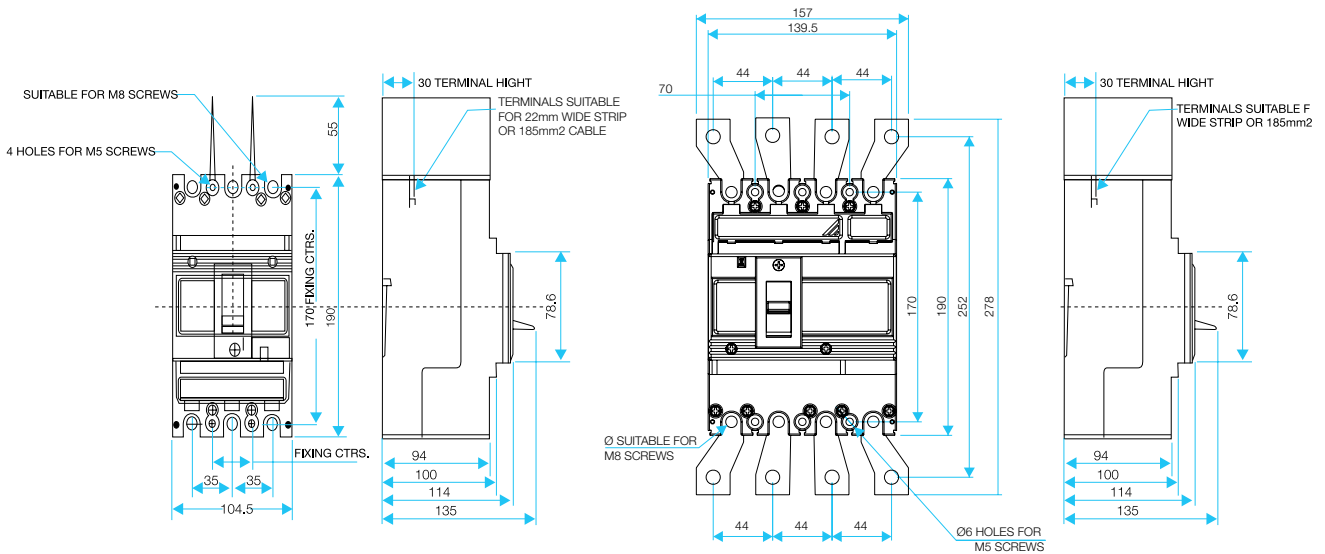

Three Pole

Four Pole with Switch Neutral

Dimensions (in mm) - Rotary Handle

Handle Fixin Details - 'F' Frame

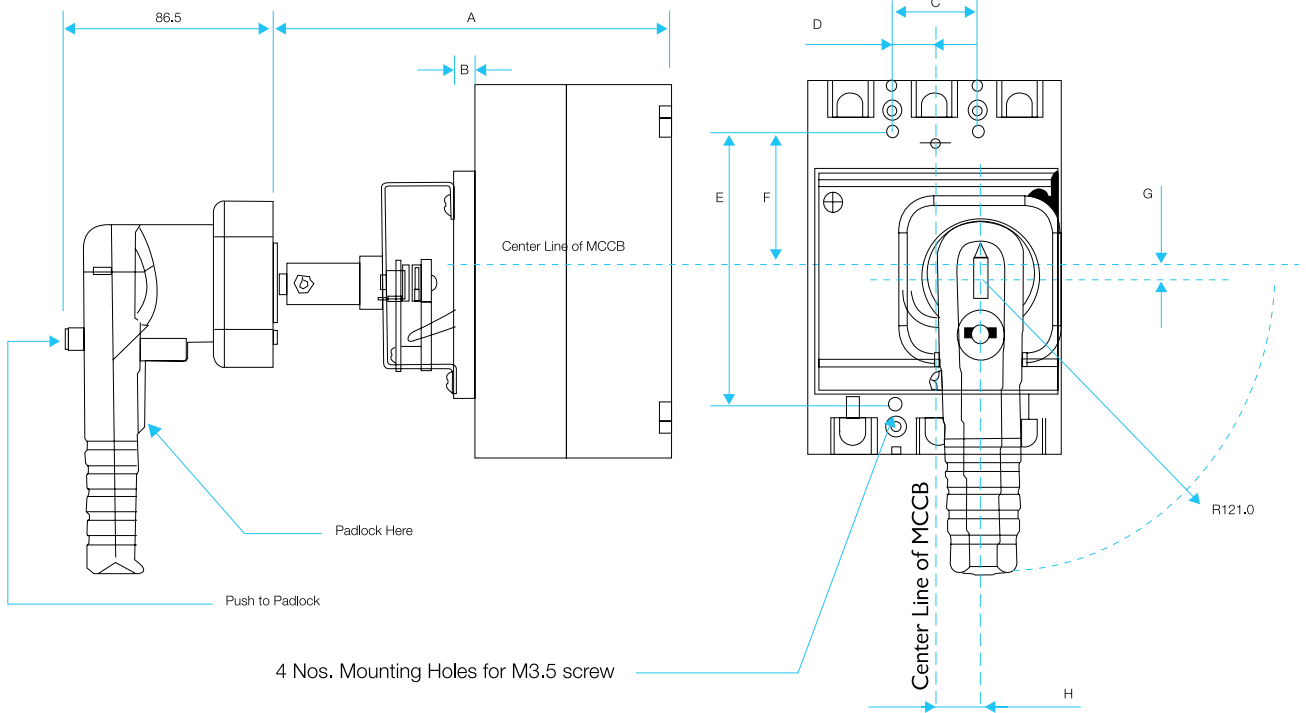

S. No.	Frame	A	B	C	D	E	F	G	H
1	F	190.0	4.25	35.0	17.5	170.0	85.0	3.75	15.0

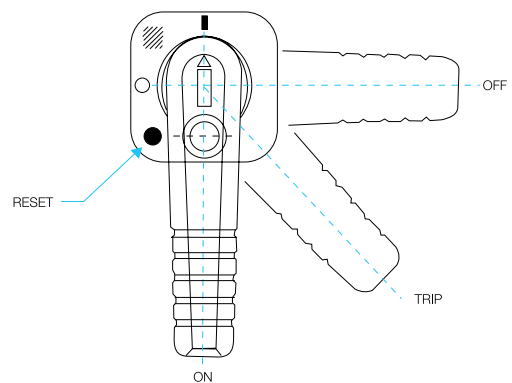
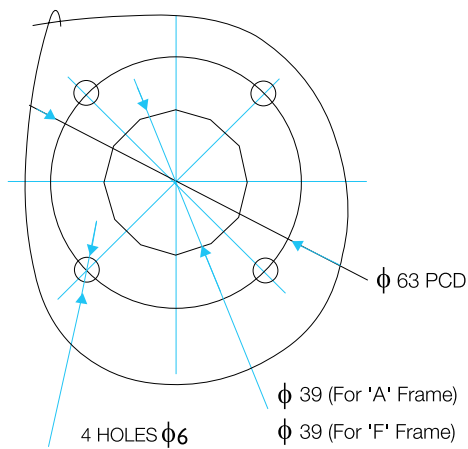

- I - MCCB ON
- O - MCCB OFF
- Trip - (In between I and O positions)
MCCB tripped by release or push to trip
- To re-close the MCCB move the handle towards position 'RESET' first till MCCB resets and then switch to position - 'I'.

LS / LN Frame MCCB



LS / LN Frame Three Pole / Four Pole MCCB (TAMF)				
	Three Pole		Four Pole	
Current Rating (A)	Icu 36kA at 415V Cat. No.	Icu 50kA at 415V Cat. No.	Icu 36kA at 415V Cat. No.	Icu 50kA at 415V Cat. No.
250	IHLLSEBT0250	IHLLNFBT0250	IHLLSEBF0250	IHLLNFBF0250
320	IHLLSEBT0320	IHLLNFBT0320	IHLLSEBF0320	IHLLNFBF0320
400	IHLLSEBT0400	IHLLNFBT0400	IHLLSEBF0400	IHLLNFBF0400
500	IHLLSEBT0500	IHLLNFBT0500	IHLLSEBF0500	IHLLNFBF0500
630	IHLLSEBT0630	IHLLNFBT0630	IHLLSEBF0630	IHLLNFBF0630



LS / LN Frame Three Pole / Four Pole MCCB (TAMA)				
	Three Pole		Four Pole	
Current Rating (A)	Icu 36kA at 415V Cat. No.	Icu 50kA at 415V Cat. No.	Icu 36kA at 415V Cat. No.	Icu 50kA at 415V Cat. No.
250	IHLLSECT0250	IHLLNFCT0250	IHLLSECF0250	IHLLNFCT0250
320	IHLLSECT0320	IHLLNFCT0320	IHLLSECF0320	IHLLNFCT0320
400	IHLLSECT0400	IHLLNFCT0400	IHLLSECF0400	IHLLNFCT0400
500	IHLLSECT0500	IHLLNFCT0500	IHLLSECF0500	IHLLNFCT0500
630	IHLLSECT0630	IHLLNFCT0630	IHLLSECF0630	IHLLNFCT0630

Dimensions (in mm) - Rotary Handle

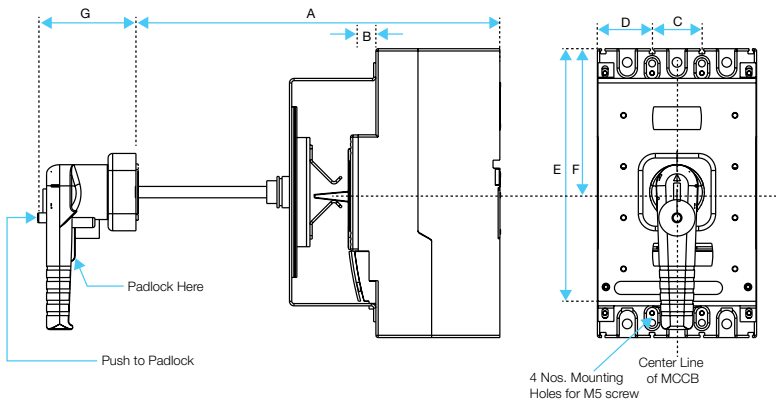

Frame	A	B	C	D	E	F	G
L	415.0	6.8	43.75	21.87	211.0	104.5	86.5

Dimensions (in mm)

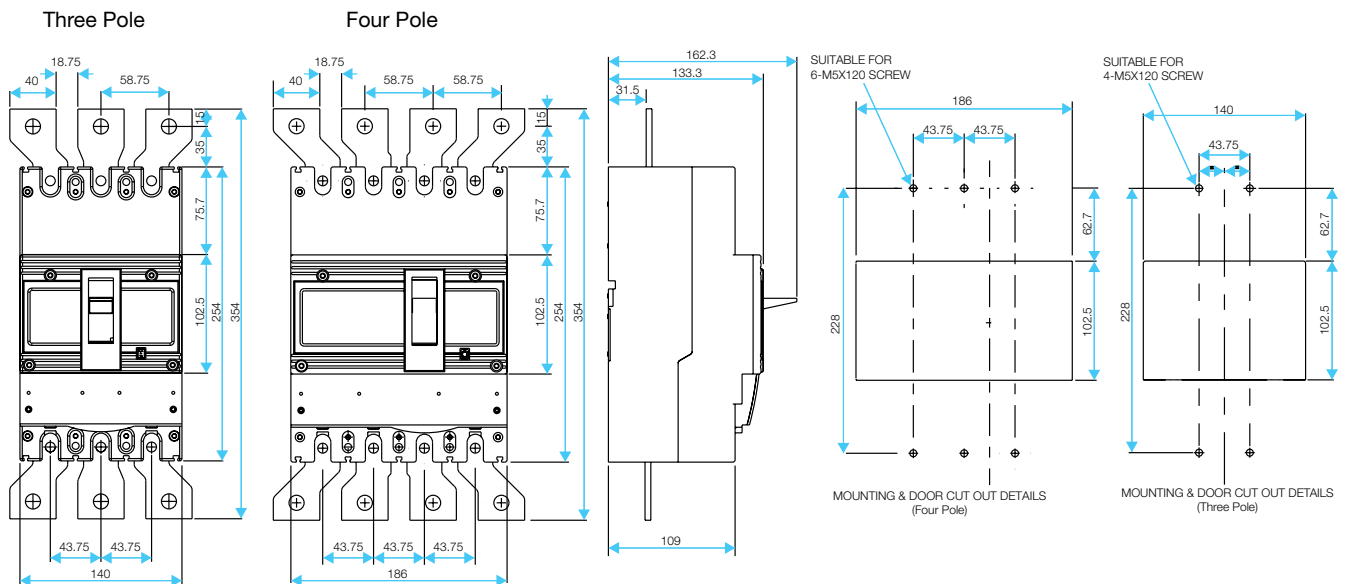

LS / LN Frame Accessories

Alarm Switch



Voltage	Rating	Configuration	Cat. No.
240 Vac	1A	1NO + NC	IHLB000

Shunt Trip with Auxilary switch

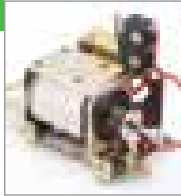

Voltage	Cat. No.
110Vac	IHLLS110
240Vac	IHLLS240
415 Vac	IHLLS415

Note: Shunt Trip release is provided with built-in auxiliary contact

Under Voltage Release

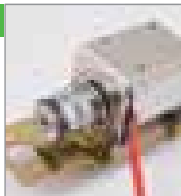

Voltage	Cat. No.
110 Vac	IHLLU110
240 Vac	IHLLU240
415 Vac	IHLLU415

Note: The breaker trips if the supply voltage dips below 70%- 35% of the rated voltage.

The breaker cannot be switched ON unless there is a supply to the UVR. (NVNC feature).

Suplied with external mounting Electronic Power pack to operate on AC supplies.

Auxiliary Switch



Voltage	Current Rating (AC12)	Configration	Cat. No.
250Vac	4 Amps	(1NO+1NC)	IHLLA1CO
250Vac	4 Amps	2(1NO+1NC)	IHLLA2CO

Rotary Handle



Rotary Handle	Cat. No.
With Door interlock and 300mm remote shaft	IHLRLN30

Dolly Pad Lock



	Cat. No.
Dolly Extension	ISCPSTMLLX009
Dolly Pad locking device	IHLLP000

Extended terminal with phase barrier

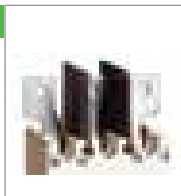

	Cat. No.
Extended terminals (250A-400A)	ISSLX0013
(500A-630A)	ISSLX0014
Phase Barriers	ISSLLX0004

CN/CH Frame MCCBs



CN Frame Three Pole MCCB	
Current Rating (A)	Icu 35kA at 415V Cat. No.
160	IHLCNT0160
200	IHLCNT0200
250	IHLCNT0250
315	IHLCNT0315
400	IHLCNT0400
500	IHLCNT0500
630	IHLCNT0630
800	IHLCNT0800



CN Frame Four Pole wSN MCCB	
Current Rating (A)	Icu 35kA at 415V Cat. No.
160	IHLCNF0160
200	IHLCNF0200
250	IHLCNF0250
315	IHLCNF0315
400	IHLCNF0400
500	IHLCNF0500
630	IHLCNF0630
800	IHLCNF0800



CH Frame Three Pole MCCB	
Current Rating (A)	Icu 50kA at 415V Cat. No.
160	IHLCHT0160
200	IHLCHT0200
250	IHLCHT0250
315	IHLCHT0315
400	IHLCHT0400
500	IHLCHT0500
630	IHLCHT0630
800	IHLCHT0800



CH Frame Four Pole wSN MCCB	
Current Rating (A)	Icu 50kA at 415V Cat. No.
160	IHLCHF0160
200	IHLCHF0200
250	IHLCHF0250
315	IHLCHF0315
400	IHLCHF0400
500	IHLCHF0500
630	IHLCHF0630
800	IHLCHF0800

CN/CH Frame Accessories

(Accessories are for 3P / 4P wSN)

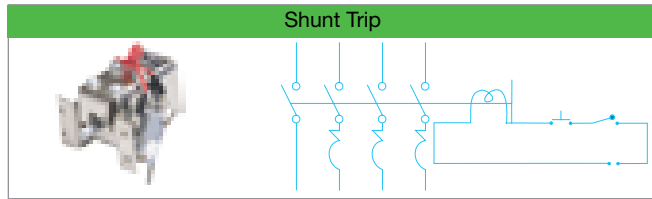

Voltage	Cat. No.
100-110Vac	IHLCS110
220-240Vac	IHLCS240
380-415 Vac	IHLCS415

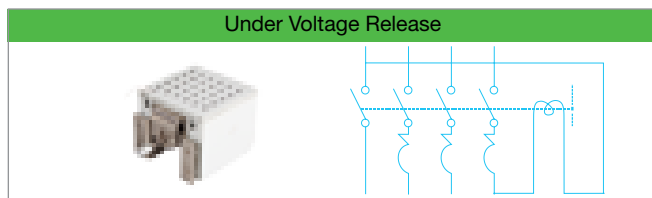

Voltage	Cat. No.
110-120 Vac	IHLCU110
220-240 Vac	IHLCU240
380-440 Vac	IHLCU440

The breaker trips if the supply voltage dips below 70% to 35% of the rated voltage.

The breaker cannot be switched ON unless there is a supply to the UVR. (NVNC feature).

Supplied with external Power pack to operate on AC supplies.

Additional transformer is supplied with ILUVR440 & ILUVR110.

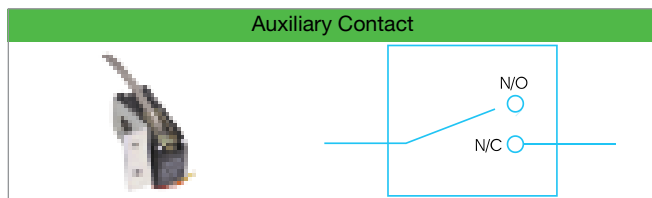

Auxiliary Contact (250Vac / 250Vdc) (450Vac / 250Vdc)

1. Change Over (1NO+1NC)	IHLLASC1CO
2. Change Over (2NO+2NC)	IHLLASC2CO

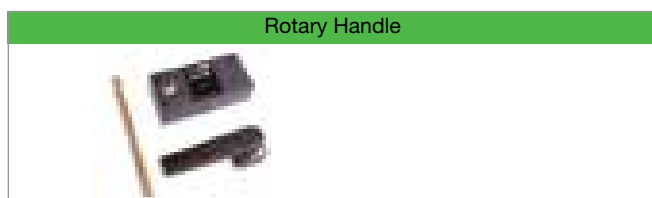

	Cat. No.
With Door interlock and 300mm remote shaft	IHLRRHC30

CN/CH Frame MCCBs

Back Studs



	Cat. No.
Back Studs (Upto 400A)	IHLLBSC400

Other Accessories

	Cat. No.
Dolly Pad locking device	IHLLDPC800
Phase Barriers	IHLLPBC800
Dolly Extension	IHLLDEC800

Dimensions (in mm)

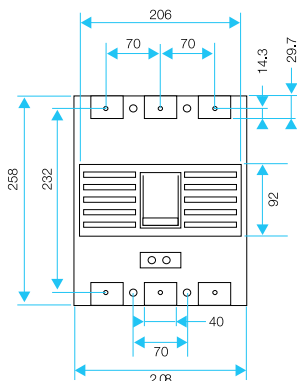

Three Pole

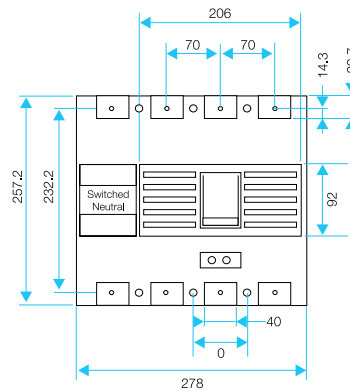

Four Pole with Switched Neutral

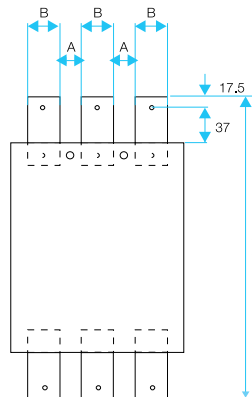
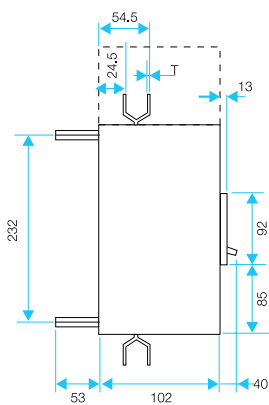

S. No.	Frame	A	B	T
1	16 - 250A	40	30	5
2	315 - 400A	20	50	5
3	500 - 800A	20	50	6

Three Pole with Extended Terminals

Dimensions (in mm) - Rotary Handle

Handle Fixing Details - 'C' Frame

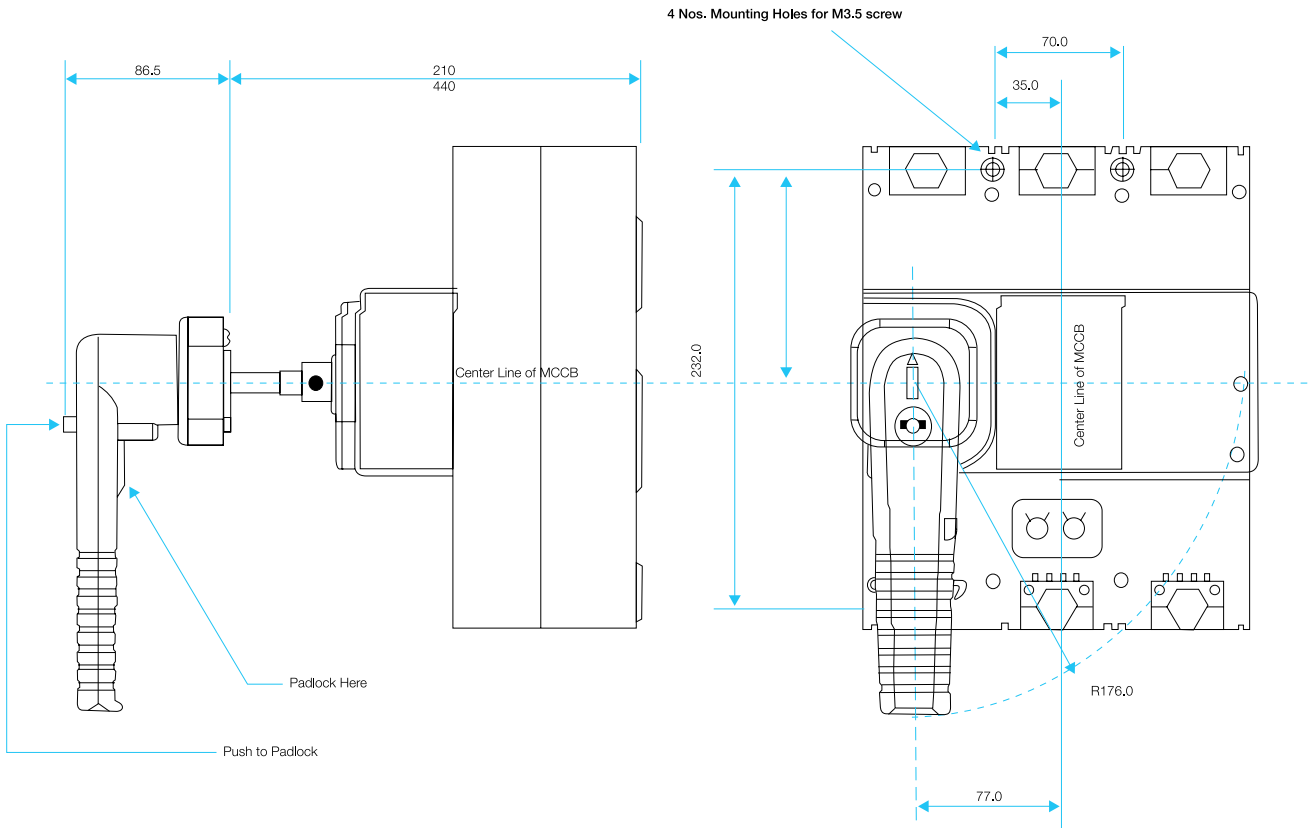

Door Cut-Out

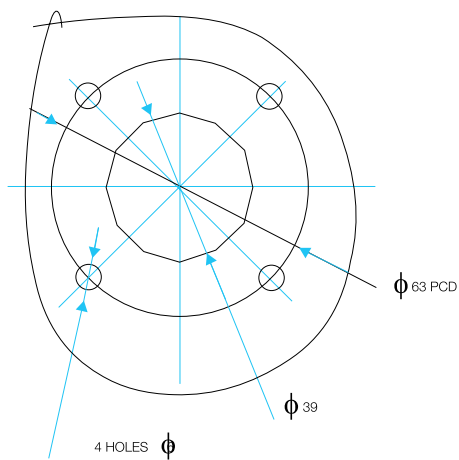

Rotary Handle Position

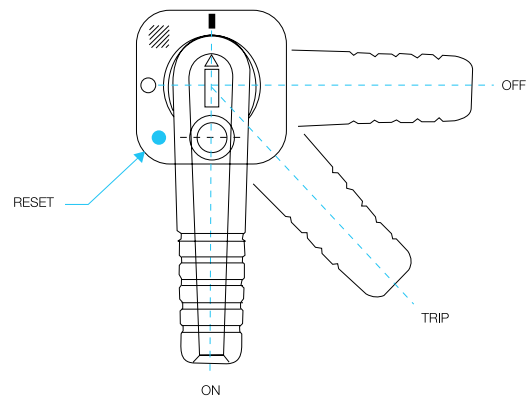

- I - MCCB ON
- O - MCCB OFF
- Trip - (In between I and O positions)
MCCB tripped by release or push to trip
- To re-close the MCCB move the handle towards position 'RESET' first till MCCB resets and then switch to position - 'I'.

DN Frame MCCBs



DN Frame MCCB - Three Pole	
Current Rating (A)	Icu 50kA at 415V Cat. No.
800	IHLDNT0800
1000	IHLDNT1000
1250	IHLDNT1250
1600	IHLDNT1600

DN Frame MCCB - Four Pole with Switched Neutral	
Current Rating (A)	Icu 50kA at 415V Cat. No.
1000	IHLDNF1000
1250	IHLDNF1250

D Frame Accessories

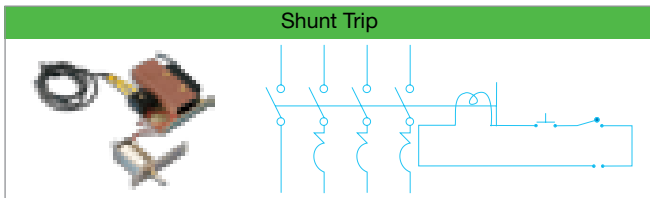

Voltage	Cat. No.
100-110Vac	IHLLSTD110
220-240Vac	IHLLSTD240
380-415 Vac	IHLLSTD415

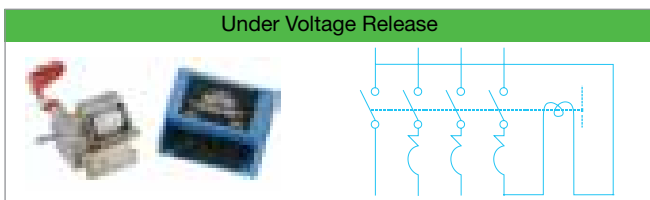

Voltage	Cat. No.
110-120 Vac	IHLUVRD110
220-240 Vac	IHLUVRD240
380-440 Vac	IHLUVRD440

The breaker trips if the supply voltage dips below 70% to 35% of the rated voltage.

The breaker cannot be switched ON unless there is a supply to the UVR. (NVNC feature).

Supplied with external mounting Power pack to operate on AC supplies. Additional transformer is supplied with LUVRD440 & LUVRD110.

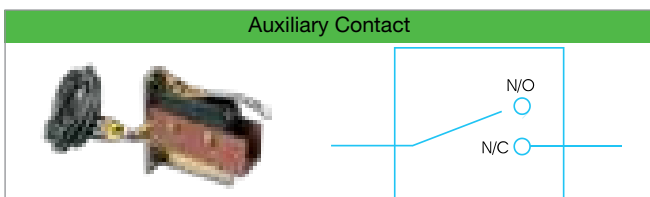

Auxiliary Contact (250Vac / 250Vdc) (450Vac / 250Vdc)	
1. Change Over (1NO+1NC)	IHLLASD1C0
2. Change Over (2NO+2NC)	IHLLASD2C1

D Frame Accessories

Rotary Handle	
	Cat. No.
With Door interlock and 300mm remote shaft	IHLRRHD30

Other Accessories	
	Cat. No.
Dolly Pad locking device	IHLDPD160
Dolly Extension	IHLDED160

Dimensions (in mm)

Three Pole

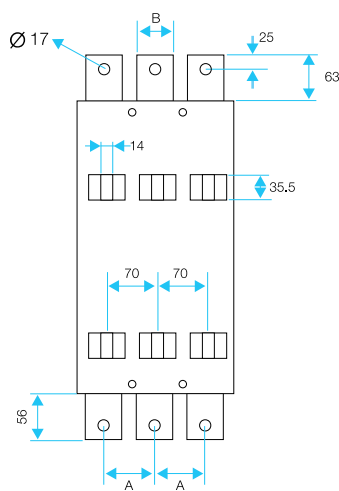
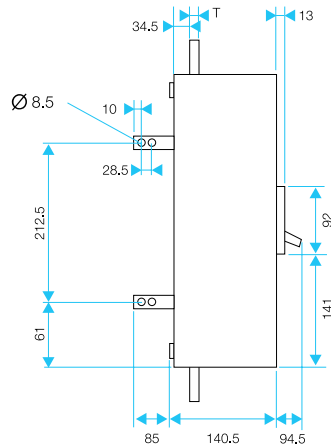
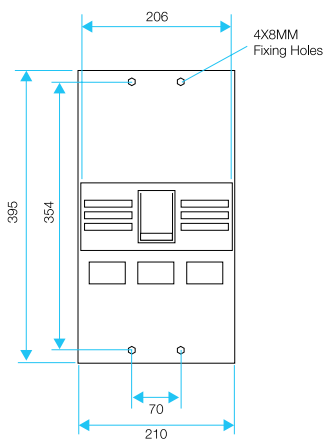

1000A

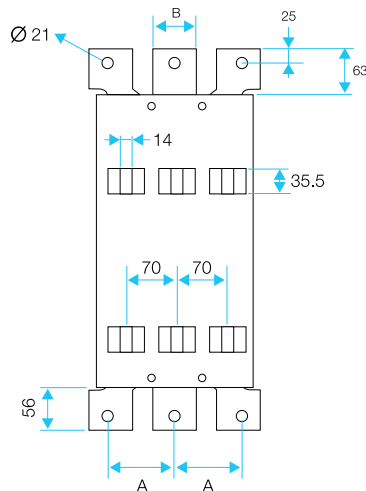

1250A - 1600A

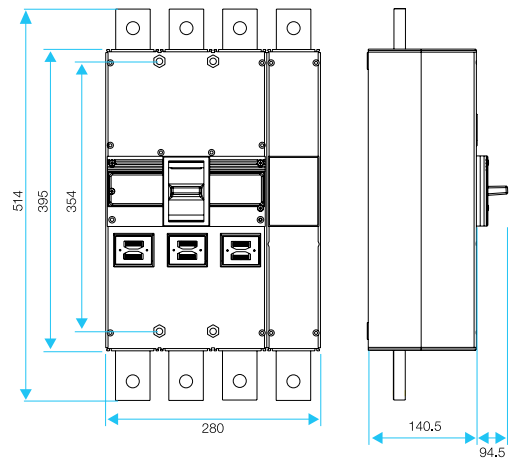

Four Pole with Switched Neutral

S. No.	Frame	A	B	T
1	1000A	70	45	15
2	1250A	82	60	15
3	1600A	87	65	18

DC MCCBs



GN Frame Three Pole MCCB	
Current Rating (A)	Icu 5kA Cat. No.
25	IHMCGNT0025
32	IHMCGNT0032
40	IHMCGNT0040
50	IHMCGNT0050
63	IHMCGNT0063
80	IHMCGNT0080
100	IHMCGNT0100
125	IHMCGNT0125



AN Frame Three Pole MCCB	
Current Rating (A)	Icu 10kA Cat. No.
160	IHMCANT0160
200	IHMCANT0200
250	IHMCANT0250



CH Frame Three Pole MCCB	
Current Rating (A)	Icu 20kA Cat. No.
160	IHMCCHT0160
200	IHMCCHT0200
250	IHMCCHT0250
315	IHMCCHT0315
400	IHMCCHT0400
500	IHMCCHT0500
630	IHMCCHT0630
800	IHMCCHT0800



DN Frame Three Pole MCCB	
Current Rating (A)	Icu 20kA Cat. No.
1000	IHMCDNT1000
1250	IHMCDNT1250
1600	IHMCDNT1600

Earth Fault Relay

The Earth Fault Relay is a common accessory for use in conjunction with all MCCB frames.

The Earth Fault detection system for use with Loadline MCCBs comprises of a core balance transformer (CT) coupled to an advanced RCD relay. The relay may be used to trip a circuit breaker via a shunt trip or an under voltage release in the event of an Earth Fault.

The relay and one of the four available CT's is all that is required for a complete earth fault sensing system suitable for the control of a circuit breaker in a circuit upto 800A fitted with either a shunt trip or an under voltage release. The simple arrangement and a small number of inter-connections necessary ensure that EFR is easily selected and installed.

The relay is suitable for 220-240V AC supply with the flexibility of choosing the sensitivity between 300mA to 1A and time delay in the range of 200m. sec - 5 sec. The required sensitivity and time delay should be selected by the dip switches provided on the facia of the relay.

Features

- No nuisance tripping
- DIN rail mounting
- Adjustable time delay
- Choice of sensitivity from 300mA upto 1A
- Trip indication LED (Red)
- ON indication LED (Green)
- Test push button
- Reset push button

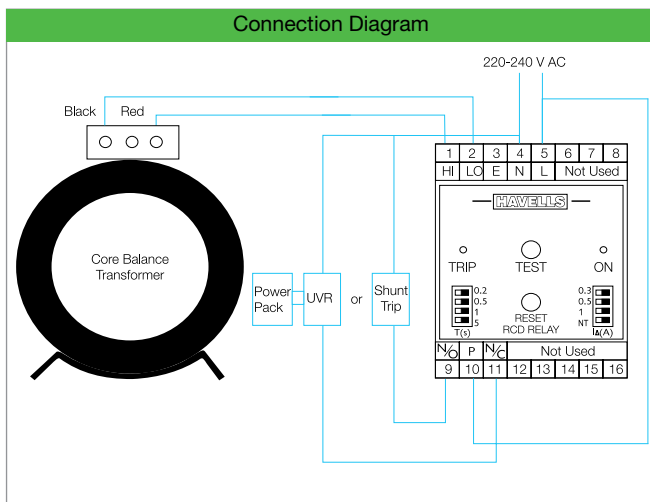

Technical Information	
Supply Voltage	220/240 V AC, 50/60 Hz
Changeover contact	5A AC-15 250V
Sensitivity	300mA, 500mA, 1A, NT
Time delay (m. sec.)	200, 500, 1000, 5000

Note: Option to By-Pass EFR in NT position available with dip switch.

Core Balanced Current Transformer			
Size	Current Rating	Dimension	Shape
1.	25-100A	60mm	Circular
2.	125-200A	95mm	Circular
3.	250-400A	145mm	Circular
4.	500-800A	300 x 80 mm	Rectangular



Earth Fault Relay

MCCB Current Rating (A)	Cat. No.
25 - 100	IHEF1100
125-200	IHEF2200
250-400	IHEF3400
500-800	IHEF4800

The earth fault relay is supplied with the CT based on the current rating. To operate the EFR, a shunt trip or an under voltage release is necessary which has to be ordered separately.

Dimensions (in mm)

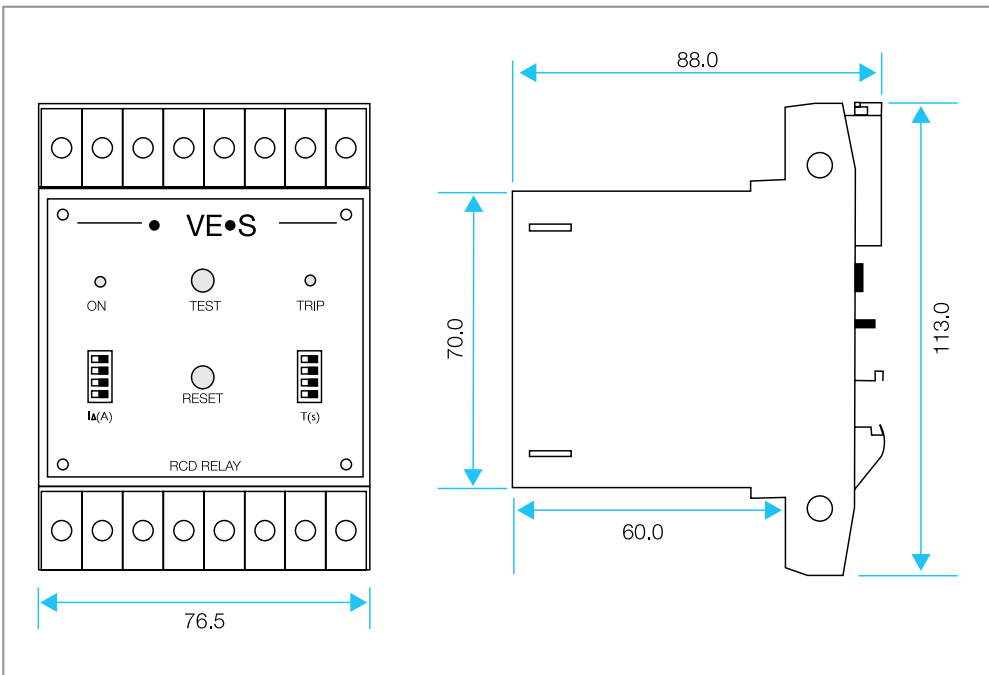

General Purpose Enclosure



Enclosures made of special grade CRCA steel are available for housing G, A and C Frame MCCBs upto 800A. They are manufactured with latest technology using CNC Punch and Brake presses to attain highest degree of perfection. The enclosures are painted with latest techniques in powder coating using epoxy polyester and polyester resin based powder paints to ensure smooth, scratch resistant surface coatings. They are suitable for wall mounting & adequate knockouts are provided for cable entry.

Dimension (in mm)

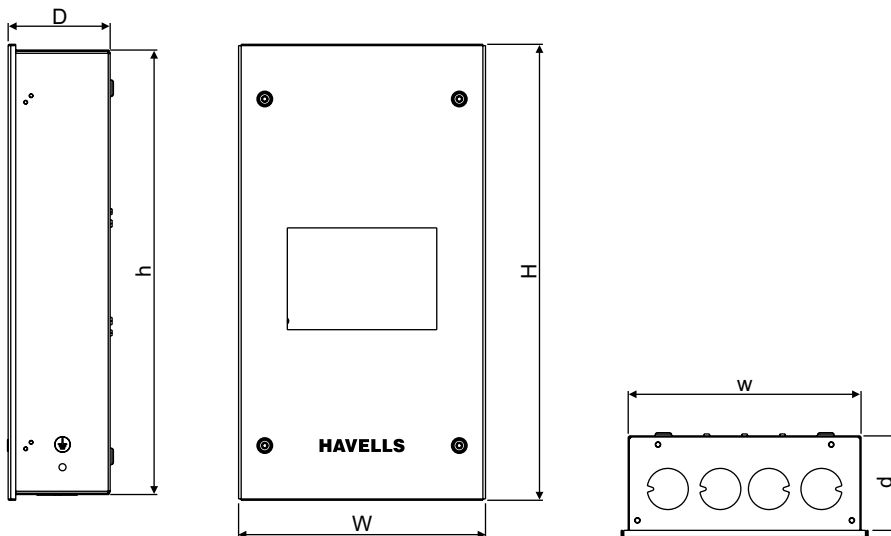

Discription	Cat. No.
S Frame 63A TP	IHESTP6
S Frame 63A FP	IHESFP6
S Frame 100A TP	IHESTP10
S Frame 100A FP	IHESFP10
G Frame 160A TP	IHEGTP
G Frame 160A FP	IHEGFP
A Frame 250A TP	IHEATP
A Frame 250A FP	IHEAFP
F Frame 250A TP	IHEFTP
F Frame 250A FP	IHEFFP
C Frame 400A TP	IHECTP
C Frame 400A FP	IHECFP
C Frame 800A TP	IHECTS
C Frame 800A FP	IHECFS

Discription	Rating	H	h	D	d	W	w
S Frame	100A	264	252	64	57	170	160
G Frame	160A	310	300	82	75	200	190
A Frame	250A	421	410	97	87	226	215
F Frame	250A	570	560	122	210	260	120
C Frame	400A	710	700	130	123	410	400
C Frame	800A	975	760	122	115	440	425



Let Through Energy (I^2t) Characteristics

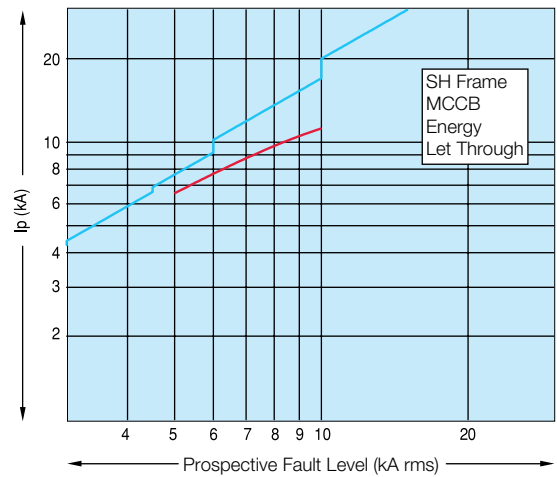
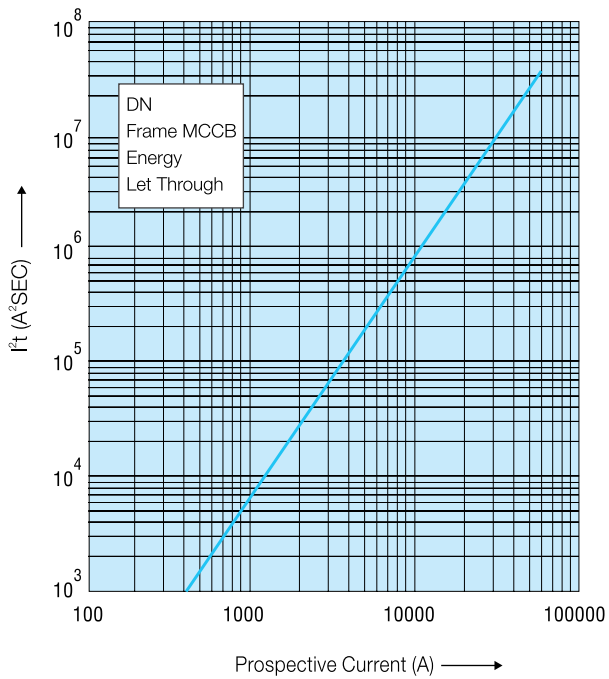
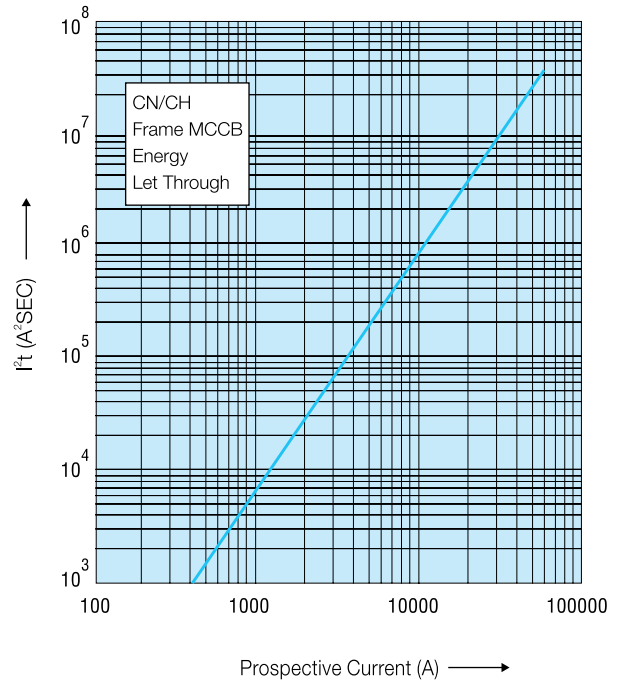
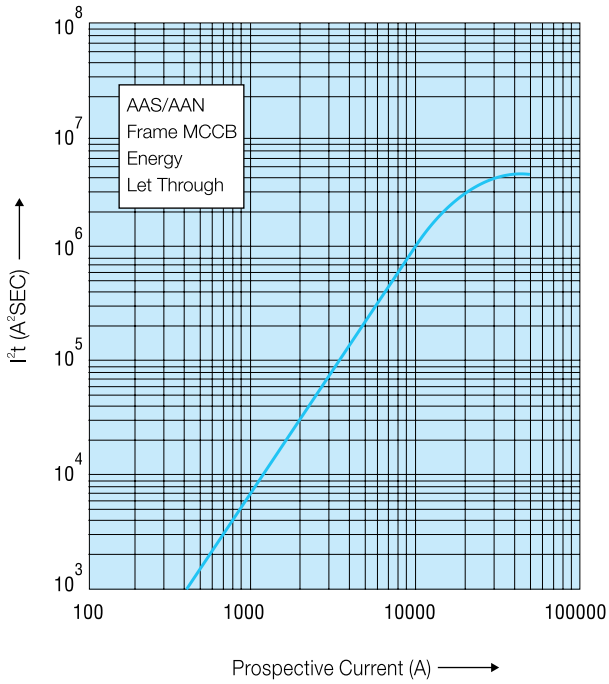

Tripping Characteristics

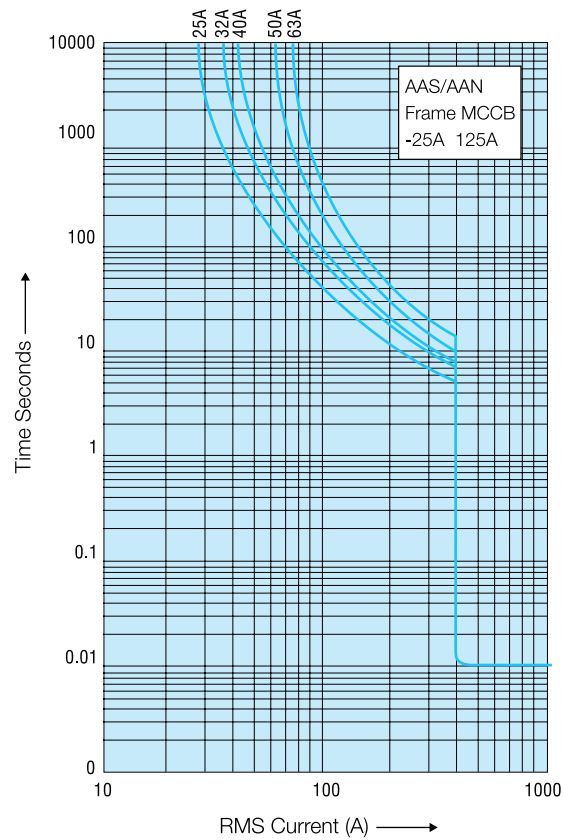
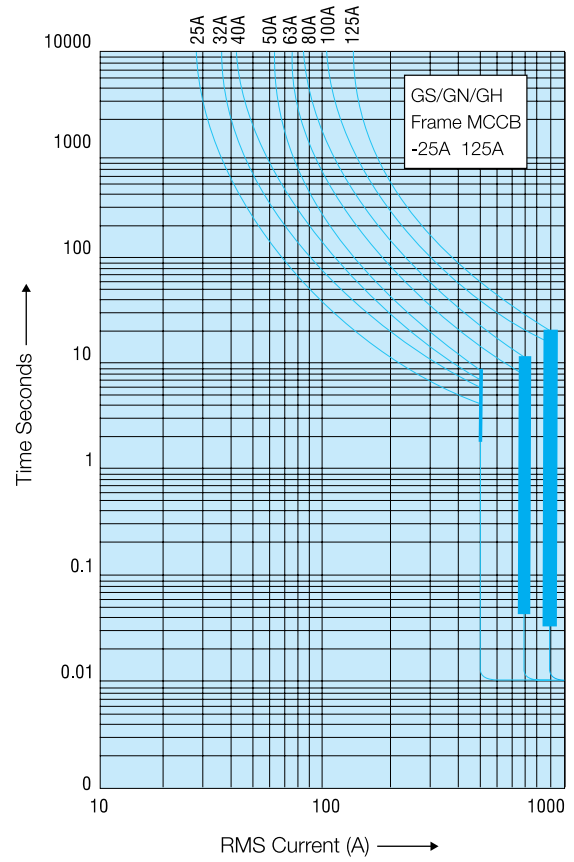
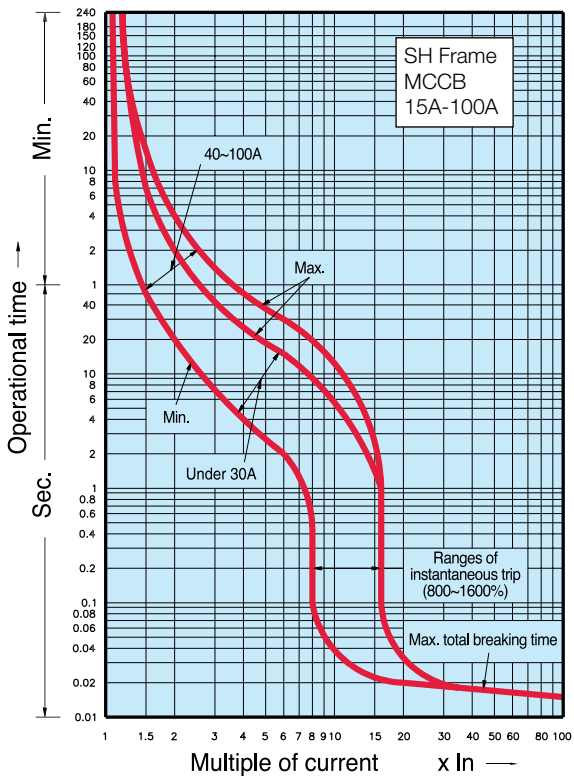

Tripping Characteristics

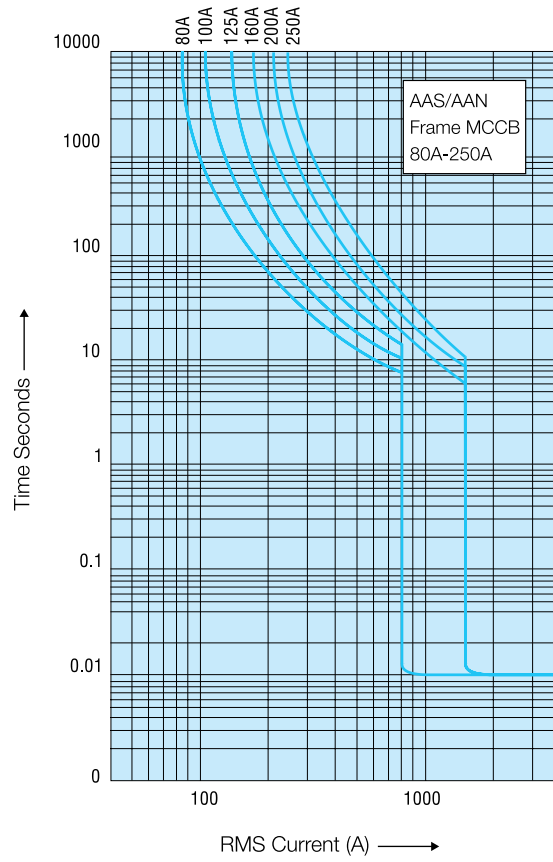

Time current characteristic curve of F-Frame MCCB
Tolerance on instantaneous current + 10%

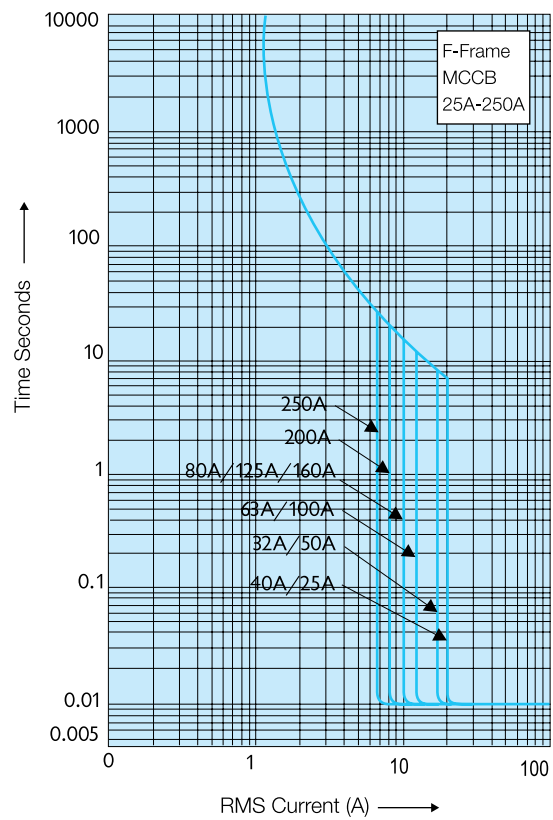

Tripping Characteristics

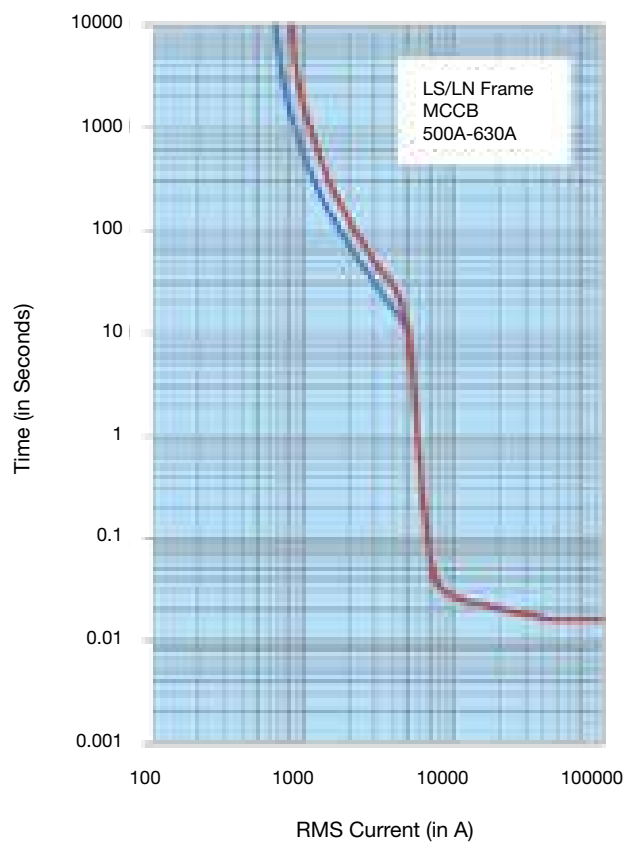
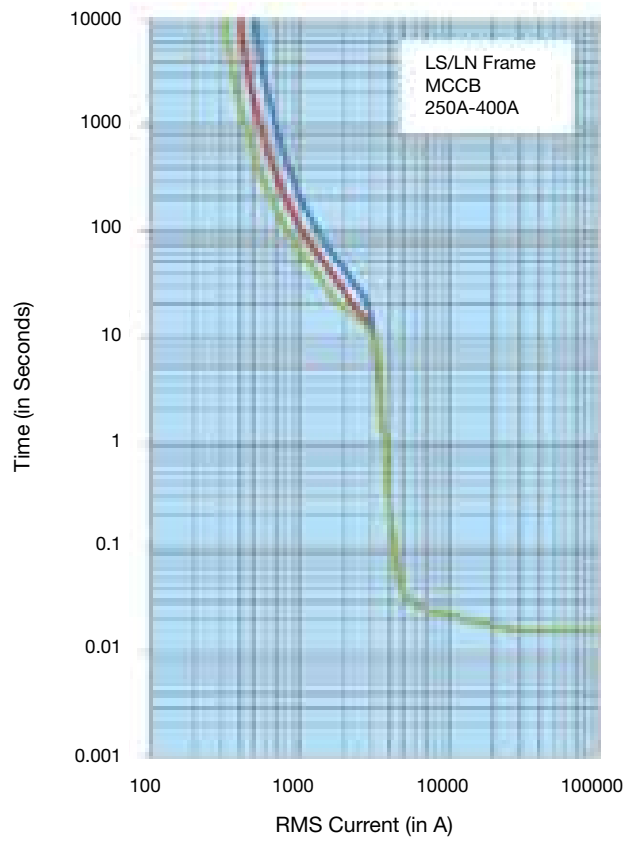

Tripping Characteristics

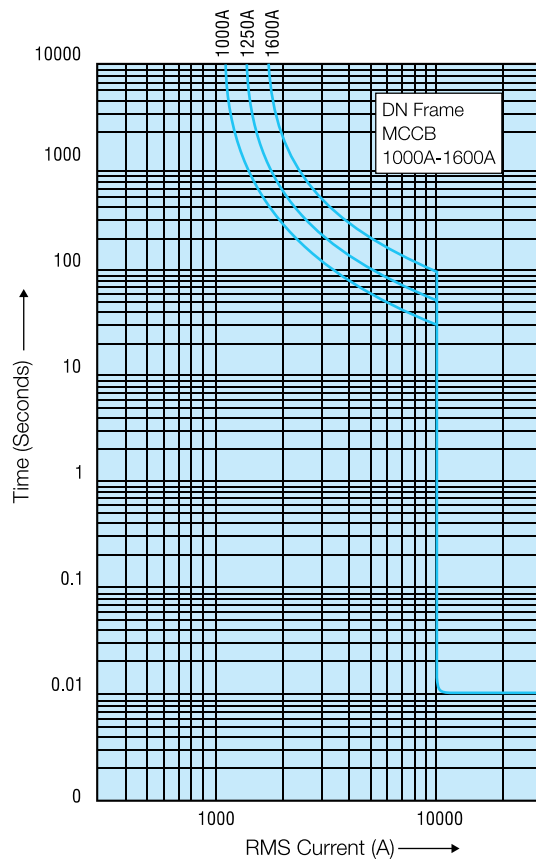
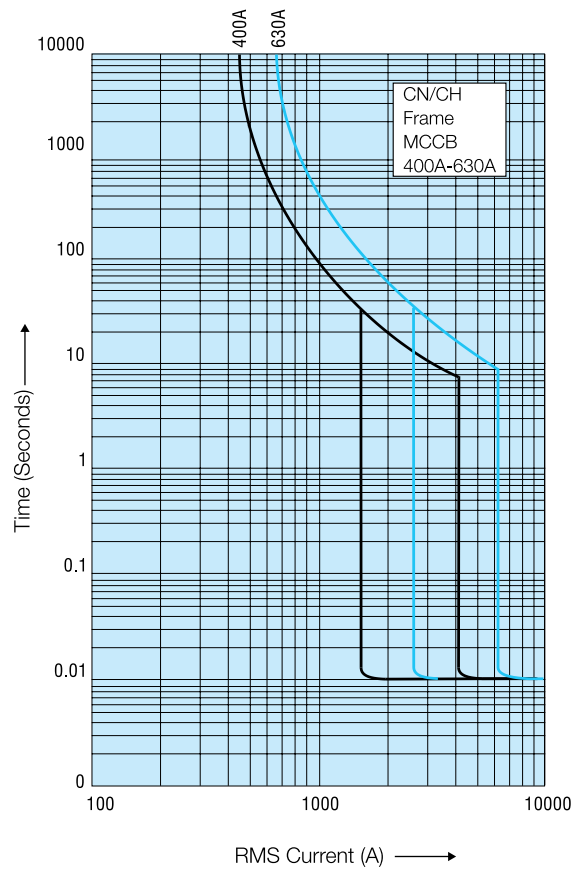
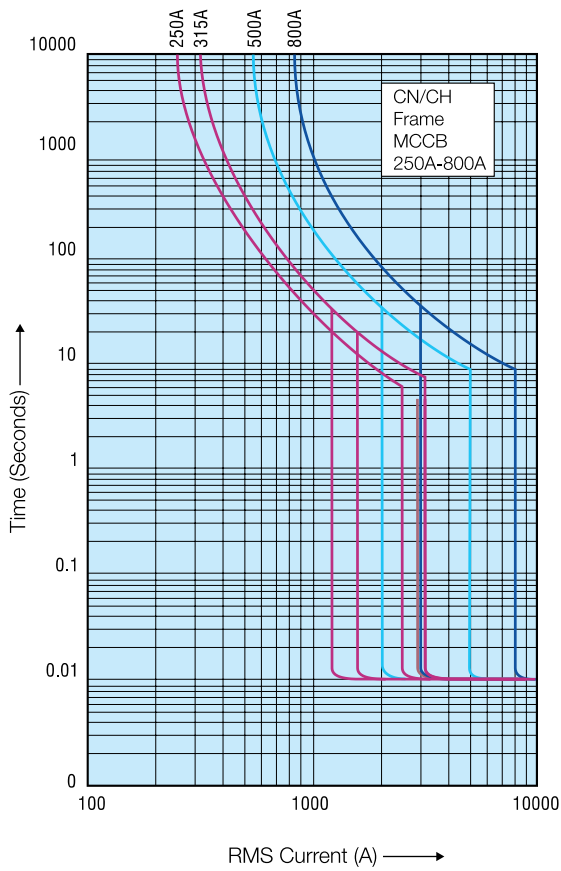

Ambient Temperature Compensation
Chart (G, A, C & F Frame Mccbs)

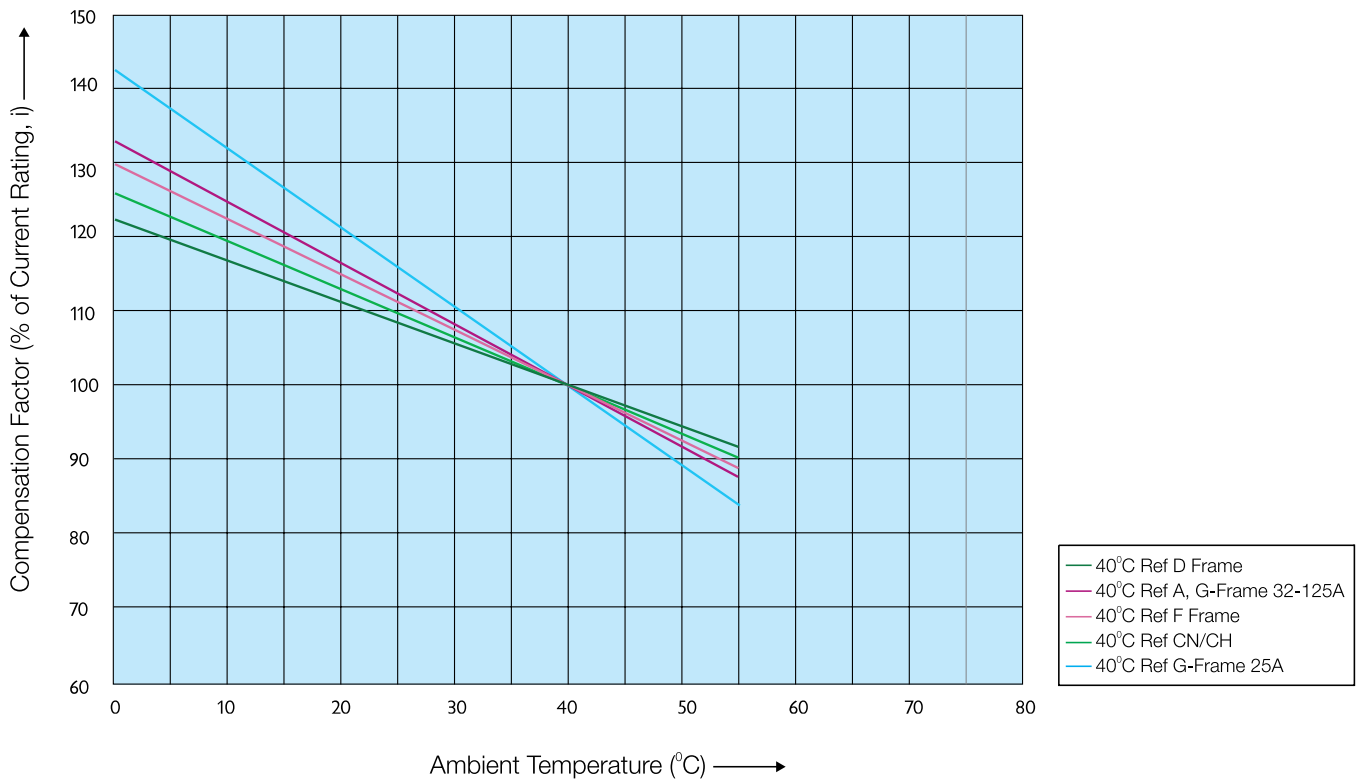

Discrimination Data

Loadline MCCB upstream device Instantaneous Trip Set at HIGH

Product	Rating	KA@	Loadline AAS/AAN										Loadline CN/CH										Loadline DN	
	(A)	415V	25	32	40	50	63	80	80	80	100	125	160	200	ALL	250	315	400	500	630	800	1000	1250	1600
Loadline AAS/AAN	63	25					800	800	800	1600	1600	1600	1600	1600	1600	2500	3000	4000	5000	6300	8000	9200	9200	9200
	80	25								1600	1600	1600	1600	1600	2500	3000	4000	5000	6300	8000	9200	9200	9200	9200
	100	25								1600	1600	1600	1600	1600	2500	3000	4000	5000	6300	8000	9200	9200	9200	9200
	125	25								1600	1600	1600	1600	1600	2500	3000	4000	5000	6300	8000	9200	9200	9200	9200
	160	25												2500	3000	4000	5000	6300	8000	9200	9200	9200	9200	9200
	200	25												2500	3000	4000	5000	6300	8000	9200	9200	9200	9200	9200
Loadline AAM	ALL	25												2500	3000	4000	5000	6300	8000	9200	9200	9200	9200	9200
Loadline CN/CH	315	50													4000	5000	6300	8000	9200	9200	9200	9200	9200	9200
	400	50														5000	6300	8000	9200	9200	9200	9200	9200	9200
	500	50															6300	8000	9200	9200	9200	9200	9200	9200
	630	50																8000	9200	9200	9200	9200	9200	9200
	800	50																		9200	9200	9200	9200	9200
	1000	50																			9200	9200	9200	9200
	1250	50																				9200	9200	9200
	1600	50																					9200	9200

Loadline MCCB DOWN stream device Instantaneous Trip Set at LOW

The above table gives fault currents in amperes till which level the downstream breakers shall act prior to the upstream breaker.

Selection & Application

Transformer Protection

Primary side

For the protection of transformer with a circuit breaker connected to the primary side (LT primary) the no load inrush current of the transformer must be considered. The peak value of the first current wave often reaches 10-15 times the rated current and may sometimes reach as high as 20-25 times. However, the transient decays very quickly (in a few m.sec.). Thus the MCCB selected should have a magnetic setting which will not be actuated by the momentary inrush current.

Secondary side

Loadline MCCBs can be used for protection of transformer on the LT side (secondary side) as an outgoing protective device.

The rated current of the transformer is calculated as follows :

$$I_e = \frac{\text{kVA} \times 1000}{\sqrt{3} \times U_e} \text{ Amps}$$

'U_e' is the Rated Voltage at the LT side

The Breaking capacity of the breaker for protection can be calculated as :

$$I_b = \frac{I_e}{Z\%} \times 10^{-3} \text{ Kiloamperes}$$

Where 'I_b' is the rated breaking capacity,

'I_e' the rated current

'Z%' is the percentage impedance of transformer (specified by the manufacturer)

Selection table For Transformer Protection

MCCB Rating in Amps										
Transformer	SH/GS	GN	GH	AAS	AAN	LS	CN	LN	CH	DN
Rating (KVA)	10kA	16kA	25kA	25kA	35kA	36kA	35kA		50kA	50kA
16	25	25	25	25	25					
25	40	40	40	40	40					
63	100	100	100	100	100					
100				160	160		160		160	
160				250	250	250	250	250	250	
200						315	315	315	315	
250						400	400	400	400	
315						500	500	500	500	
400						630	630	630	630	
500							800		800	
630										1000
750										1200

Selection Table for DG Set Protection

DG Set Rating (KVA)	MCCB Rating (Amps)
10	16
16	25
25	40
63	100
100	160
160	250
200	315
250	400
315	500
400	630
630	1000
750	1200

Generator Set Protection

Loadline MCCBs can be used for the effective protection and control of Diesel Generating set against overload and short circuits.

The Current rating of MCCB to be selected is calculated as follows :

$$\text{kVA} = \sqrt{3} U_e \times I_e$$

or

$$I_e = \frac{\text{kVA}}{\sqrt{3} \times U_e}$$

Where,

kVA = Rating of the DG Set

U_e = Rated Voltage

I_e = Rated Current

The MCCB rating selected is greater than or equal to the rated current value

Selection & Application

Feeder / Cable Protection

An estimation of the prospective short-circuit current (psc) in an installation is an important consideration in the selection of the appropriate protective device.

The magnitude of the short-circuit current (rms value of the AC component) at a point in the installation will depend upon;

- (A) Prospective short-circuit current at the origin of the installation.
- (B) The amount of resistance in the circuit between the origin of the installation and the point at which the short circuit occurs.
- (C) The type of short-circuit, phase to phase or phase to earth or phase to neutral.

It is possible to arrive at a maximum prospective short circuit value at the origin by taking the transformer kVA rating and its impedance and calculating from the expression :

$$SC \text{ kA} = \frac{\text{Transformer rating (kVA)} \times 100}{\sqrt{3} \times \text{Secondary voltage} \times \% \text{ impedance of transformer}}$$

To calculate the resistance in the LV circuit, obtain details of lengths and sizes of cables between the source of supply and the point under calculation. Using the table provided, determine the sum of cable resistances and then simply read off the estimated fault current from the relevant transformer curve on the graph.

The values assume a symmetrical fault across the three phases. In a single circuit, for line to neutral faults, take the cable resistance value from the table and double it.

The selection of Loadline MCCB for feeder /cable protection depends on the total load to be protected and the prospective short-circuit current (psc) at the point of installation.

PSC at A	approximately 27kA
PSC at B resistance A to B (a)	0.30mΩ = 25kA
PSC at C +resistance A to B +resistance B to C1	0.30mΩ 10.70mΩ 11.00mΩ = 12kA
PSC at D +resistance A to B +resistance B to C +resistance C to D	0.30mΩ 10.70mΩ 46.00mΩ (b) 57.00mΩ = 3kA

- (a) 2 cables per phase divided by 2
- (b) 2 core cable, multiplied by 2

The above calculations have an inbuilt safety margin as they assume a no impedance fault condition which would not be the case in practice.

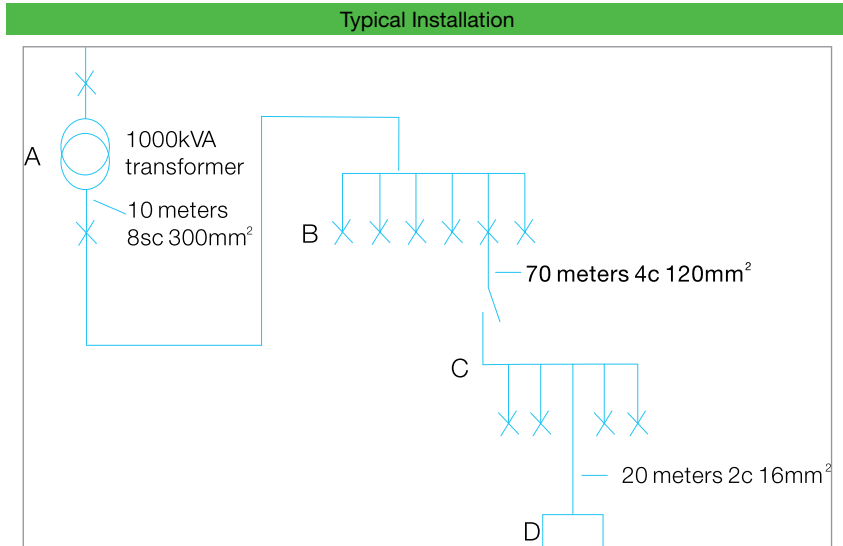

Estimating the Prospective Short Circuit Current

Estimating the Prospective Short Current

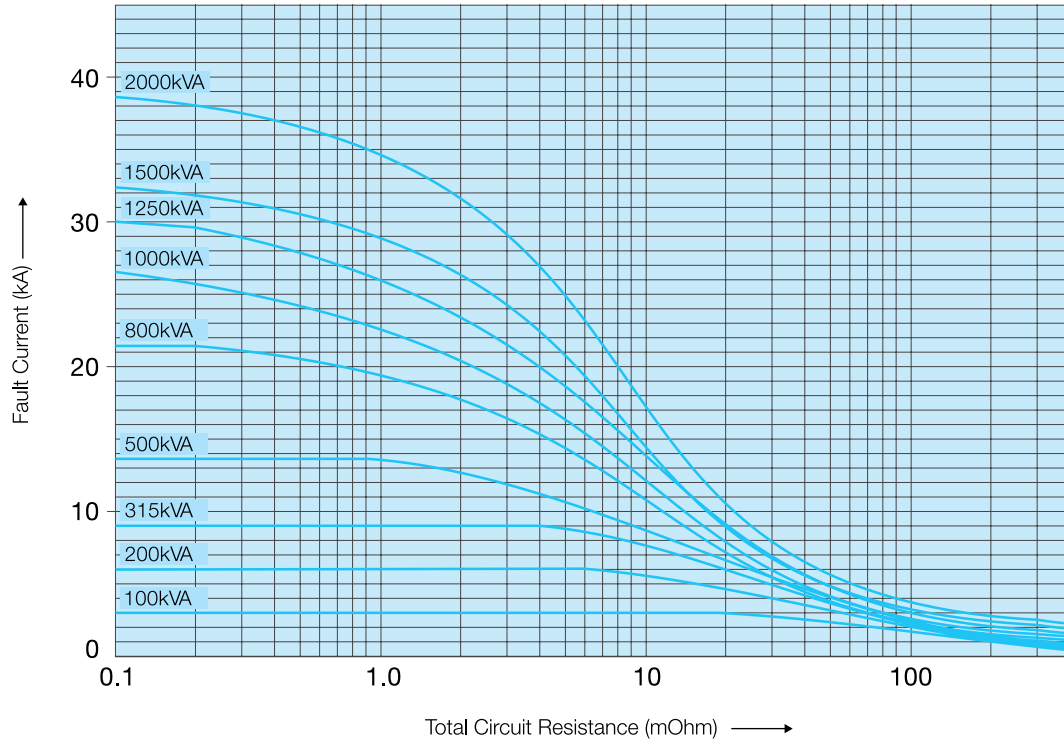

Maximum Resistance of Copper Conductors at 20°C (µOhm)

Nominal Cross-sectional Area (mm ²)	Cable Length											
	5m	10m	15m	20m	30m	40m	50m	60m	70m	80m	90m	100m
1	90.50	181.00										
1.5	60.50	121.00	182.00									
2.5	37.10	37.10	74.10	111.00	148.00							
4	23.10	46.10	69.20	92.20	138.00							
6	15.40	30.80	46.20	61.60	92.40	123.00						
10	9.15	18.30	27.50	36.60	54.90	73.20	91.50	110.00				
16	5.75	11.50	17.30	23.00	34.50	46.00	57.20	69.00	80.50	103.50		
25	3.64	7.27	10.90	14.50	21.80	29.10	36.40	43.60	50.90	58.20	65.40	72.70
35	2.62	5.24	7.86	10.48	15.70	21.00	26.20	31.40	36.70	41.90	47.20	52.40
50	1.94	3.87	5.81	7.74	11.60	15.50	19.40	23.20	27.10	31.00	34.80	38.70
70	1.34	2.68	4.02	5.36	8.04	10.70	13.40	16.10	18.80	21.40	24.10	26.80
95	0.96	1.93	2.10	3.86	5.79	7.72	9.65	11.60	13.60	15.40	17.40	19.30
120	0.77	1.53	2.30	3.06	4.59	6.12	7.65	9.18	10.70	12.20	13.80	15.30
150	0.62	1.24	1.86	2.48	3.72	4.96	6.20	7.44	8.68	9.92	11.20	12.40
185	0.49	1.00	1.49	1.98	2.97	3.96	4.96	5.96	6.94	7.93	8.92	9.91
240	0.34	0.75	1.13	1.51	2.26	3.02	3.77	4.52	5.28	6.03	6.79	7.54
300	0.30	0.63	0.90	1.20	1.80	2.80	3.00	3.61	4.21	4.81	5.41	6.01
400	0.23	0.47	0.70	0.94	1.41	1.88	2.35	2.85	3.29	3.76	4.23	4.70
500	0.18	0.37	0.55	0.73	1.10	1.46	1.83	2.20	2.56	2.93	3.29	3.66
630	0.14	0.28	0.42	0.57	0.85	1.13	1.42	1.78	2.15	2.51	2.88	3.25

Motor Control

Loadline MCCBs can be used for motor protection. Selection of MCCBs has to be done taking into consideration the starting inrush current, and the system fault levels. Further the selection is also based on type of starting, i.e. DOL or Star Delta.

DOL Starting

Care is to be taken to avoid nuisance tripping during starting of Squirrel Cage Motors since the inrush current will be in the order of 600 to 800% of the full load current of the motor. The overload setting is chosen such that it does not trip during starting

Star-Delta Starting

In Star Delta starting of motors, since there is a reduction in the starting current due to reduced voltage, the MCCBs do not have a problem in the overload setting. But the transient currents can go upto 12 times the rated current during change over from star to delta which will cause the instantaneous magnetic release to trip the breaker. So proper selection of magnetic pickup level is important for prevention of nuisance tripping during change over from Star to Delta.

It is always recommended to select an MCCB in co-ordination with Contactor and Over Load Relay so as to have the best and optimum benefit of all the devices.

Selection table for Motor Protection

Motor Rating		Approx. Full Load Current (A) at 415V	Direct On Line MCCB Rating/Type		Star/Delta MCCB Rating/Type	
HP	KW		AAN	CN/CH	AAN	CN/CH
10	7.5	14	25	-	25	-
12.5	9	17	25	-	25	-
15	11	21	25	-	25	-
20	15	28	32	-	32	-
25	19	35	40	-	40	-
30	22	41	50	-	50	-
40	30	52	80	-	63	-
50	37	69	100	-	80	-
60	45	80	-	-	100	-
75	55	97	-	-	125	-
100	75	125	-	-	160	-
125	90	156	-	250	-	-
150	112	190	-	315	-	250
175	130	225	-	315	-	315
200	149	255	-	315	-	315
220	160	275	-	400	-	400
250	186	320	-	400	-	500
300	224	375	-	500	-	500
350	261	449	-	630	-	630
400	298	505	-	630	-	630

The figures shown are based on following motor starting conditions : -

Direct online 7 X full load current for 5 seconds.

Star/Delta 4 X full load current for 12 seconds.

Selection & Application

Capacitor Control

When a capacitor circuit is opened, it exhibits characteristics distinctly

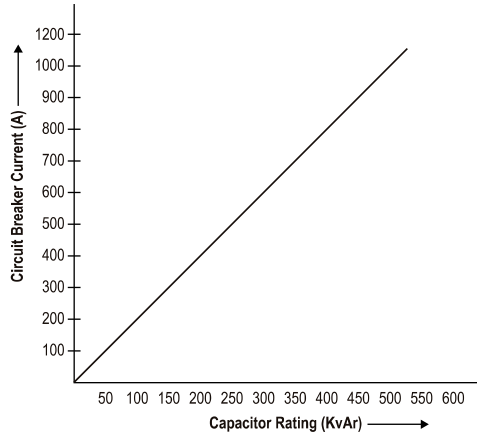

differently from inductor loads due to the effects of residual electric charge in the capacitor. The recovery voltage appears across the contacts immediately after the circuit is opened is equal to the difference between the capacitor residual voltage and supply voltage. Therefore half a cycle after the circuit opens, the voltage between the contacts of the switch rises to twice the supply voltage or higher.

In a three phase circuit the recovery voltage appearing between the contacts in the first interrupted phase could rise to as high as 2.5 times the supply voltage. Unless the breaker contacts are fully open for at least ½ cycle after the capacitor current is interrupted, restrike of arc is likely to occur. If the restrike arc is repeated, the voltage could continue to rise to the dielectric breakdown point of the capacitor. Hence, fast interrupting, quick make, quick-break circuit breakers should be used for this type of circuit.

When a capacitor circuit is closed a condenser charge $q = CU$ which corresponds to the instantaneous value 'U' of the supply voltage at closing time, must be instantaneously supplied, causing a large inrush current to flow through it. If the capacitor circuit is closed in the voltage phase at which the inrush current is maximum, the maximum value of the inrush current is approximately,

$$I_p = \frac{C}{L} \times U$$

The maximum time duration during which the maximum current flows is about 0.5 ms. Selection of a MCCB for capacitor circuit duty must therefore consider the effects of higher short circuit and inrush currents. This will affect the choice of instantaneous trip current rating. In practice, an MCCB which satisfies the following equations should be chosen.

$$I_r > 1.5 \times I_c$$

$$I_{inst} > \frac{I_p}{2}$$

Where :

- I_r = Rated current of MCCBs
- I_c = Rated current of capacitor
- I_{inst} = Short circuit pick up setting of the MCCB
- I_p = Maximum capacitor inrush current

It is therefore necessary to select a circuit breaker with current rating not less than 1.5 - 2.0 times the rated current of the capacitor.

Dc Control

MCCBs though not separately designed for DC applications are suitably modified to be able to operate on DC systems also upto 500V DC / 250V DC. This is achieved by modifying for:

- i) Current carrying capacity
- ii) Over current and short circuit protection
- iii) Short circuit breaking capacity (with L/R time constant limitations)

Current Carrying Capacity

The continuous current carrying capacity is generally a function limited by the temperature rise of various internal components of MCCBs.

The AC rating of MCCBs is expressed as "RMS" value. The DC rating is "Average" value. The RMS and average value can be related by a "Form Factor" which is 1.1.

Hence, an AC MCCB can be assigned a 10% higher DC current rating. But in practice the use of DC MCCB ratings are equal to AC ratings and thereby, temperature rise is restricted within limits.

Overload Release & Overload Protection

The overload release are generally thermal type with a Bimetal-Heater system. The heating effect which can be expressed by the factor integral I^2t varies for AC and DC. The integral (I^2t) for AC will be 1.21 times integral (I^2avt) for DC, thus an AC MCCB when used in DC circuit will trip slower. For example a 100A AC MCCB when used in DC circuit for 100A will sense a 20% overload only from 133A onwards.

To retain the same Overload characteristics as AC, it is important to separately calibrate the MCCBs for DC ratings and overload tripping characteristics need to be suitably modified.

Short Circuit Release & Short Circuit Protection

The short circuit release is actuated by the peak value of the AC sine wave. Since no such peak exists in DC, DC tripping will be slower. Hence to achieve the same short circuit pick up level in DC, the short circuit release will be calibrated specially.

Short Circuit Breaking Capacity

In AC the breaking of the short circuit current usually occurs within the first current zero, by the current limiting effect. No such current zero exists in DC. Arc breaking and ultimate quenching of arc depends on the rapid dissipation of the inductive Energy $\frac{1}{2}LI^2$

This energy dissipation is dependent on L/R or time constant of the circuit. The L/R values should be limited to 10-15 milli seconds to achieve satisfactory performance. This is achieved usually by splitting the DC arc voltage over 2 or 3 poles by connecting them in series, depending upon on the DC voltage.

Digital Moulded Case Circuit Breaker

Features:

- True RMS sensing-accurate and close protection.
- High repeat accuracy-reliable protection.
- Flexibility through multiple adjustment option-versatility and closer protection.
- Time delay on overload and short-circuit faults-suitable for discrimination.
- Built in adjustable electronic overload sensing (40% to 110% of I_n).
- Built in adjustable short-circuit current sensing (600% to 1000% of I_r).
- No external power required for basic functioning of the release.
- Built in operation-check function with Field Testing Provision.
- Accurate setting by use of DIP switches, ensuring reliable system protection/co-ordination.

Range :

25A, 40A, 63A, 100A, 125A, 160A, 200A, 250A, 400A & 630A in three pole and four pole execution.

Specification :

Conforms to

IEC : 60947-2 / IS: 13947-2 EMI/EMC

IEC : 61000-4-2 (ESD Test)

IEC : 61000-4-3 (Radiated Electromagnetic Field Test)

IEC : 61000-4-4 (EFT Test)

IEC : 61000-4-5 (Surge Test)

IEC : 61000-4-6 (Conducted Disturbances Test)

Digital range microprocessor based electronic MCCBs are designed and manufactured to world-class standards. These MCCBs provide high level of breaking capabilities and offer close, accurate and reliable protection against overload, short-circuit and ground fault through multiple adjustment options. The user-friendly breaker comes with a wide range of internal/external accessories.



Loadline Digital

Moulded Case Circuit Breaker

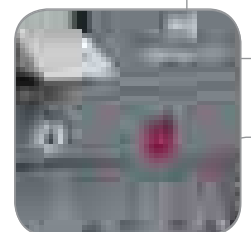

Loadline Digital Moulded Case Circuit Breakers have precision formed moulded case and cover of high performance resin bonded thermoset material. The circuit breakers are designed to allow grouping in distribution panels or switchboards to present their operating handles and label escutcheons uniformly aligned in a single panel cutout.

The **switching mechanism** is Quick make-Quickbreak type and is trip free, i.e. the breaker trips internally even if the operating knob is held in ON position.

The **contact mechanism** comprises of fixed and moving contacts made of sintered silver alloy for reliability, long life and anti-welding properties. Arcing contacts are provided in higher frames, further increasing the contact life.

The **arc extinguishing** device comprises of arc chutes having grid plates mounted in parallel between supports of insulating material. The arc is divided between these grid plates which helps in its fast quenching. The arc is thus confined, divided and extinguished in the arc chute. The excellent insulation between the conducting parts and better energy dissipation after short circuit makes it possible to make the load and line connections on either side

The **tripping mechanism** comprises of magnet holder trigger which is coupled to the single trip bar unit to avoid single phasing. The electronic circuit gives a signal to this unit in case of over current fault and this unit further trips the MCCB.

Over current protection The sensing of the current is through the current transformers fitted on the main terminals. In the case of any fault the secondary output of the CT increases. This secondary output of CT goes to the micro controller based electronic circuit. The micro controller is programmed to give a signal as per inverse time characteristics. The signal in the form of DC supply is given to magnet holder trigger which trips the MCCB. The tripping time and tripping current can be set with the help of the DIP switches provided on the front panel of the MCCB.

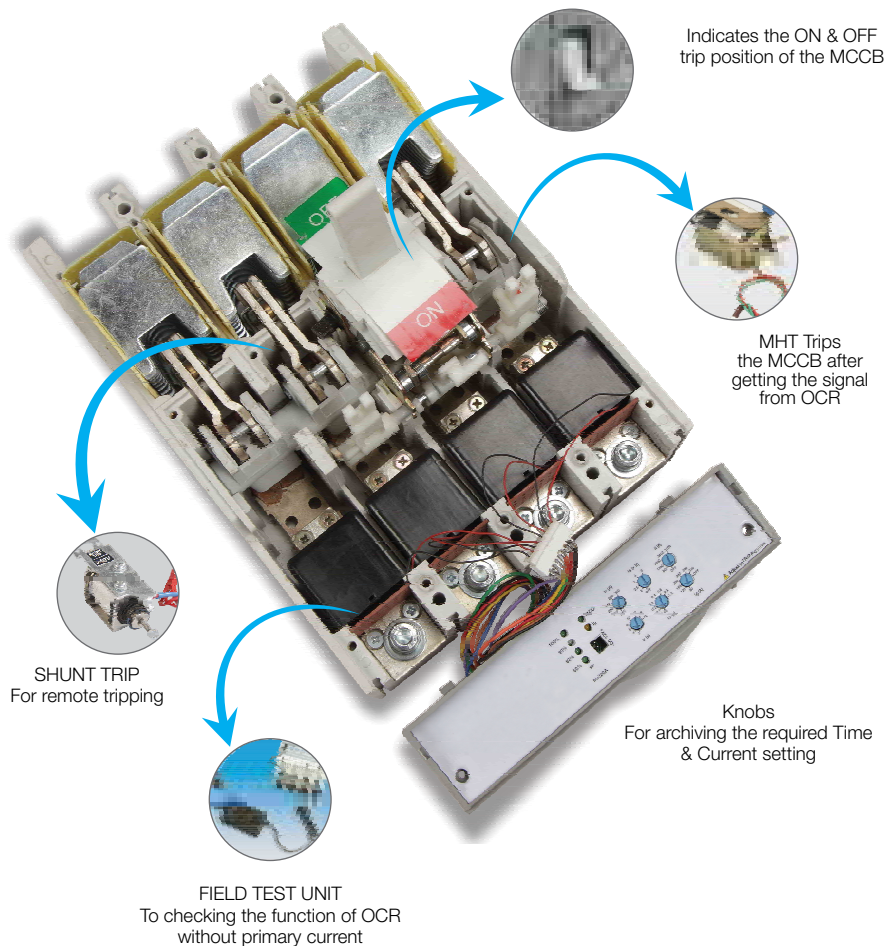

Technical Information

Standard conformity	:	IEC 60947-2/IS13947-2
Rated operational voltage	:	415V AC
Rated Insulation Voltage	:	690V AC
Type of release	:	Microprocessor Based Electronic Release
Utilisation Category	:	A
Rated frequency	:	50/60Hz
Operating altitude	:	2000 metres
Humidity	:	0 - 90%
Rated impulse voltage	:	8 kV



Frame		FEN	FEH
No. of Poles		3, 4	3, 4
Standard Current ratings (In)	A	25, 40, 63, 100, 125, 160, 200, 250	
Rated ultimate short circuit breaking capacity (Icu),	kA		
	380V	40	50
	415V	35	50
Rated service short circuit Breaking Capacity (% of Icu)	(Ics)	100%	75%
Rated short circuit Making capacity (Peak), Icm	kA	73.5	105
Weight	TP (Triple Pole)	Kg	3.4
	FP (Four Pole)		4
Terminal Type Cable		M8	M8
	Terminal capacity (Cable)	Sq.mm	185
	(Bus bar width)	mm	18
Internal Accessories #			
Auxiliary Switch	(1 C/O or 2C/O)	•	•
Shunt Trip (built-in auxiliary contact)		•	•
Under Voltage Release		•	•
Alarm Switch	(1 C/O)	•	•
External Accessories			
Earth Fault Relay		•	•
Rotary Handle		•	•
Back Studs		•	•
Extended Terminals (above 63A)		+	+
Phase Barriers		+	+
Terminal Shrouds		•	•
Dolly pad locking Device		•	•
Field Test Unit		•	•
Characteristics of Microprocessor Based Release		©	©
Overload Current I1	xIn (A)	0.4-1.1 in steps of 0.1©	0.4-1.1 in steps of 0.1©
Overload Time Delay t1	Sec	1, 5, 10,15, 20, 25, 30, 35	1, 5, 10,15, 20, 25, 30, 35
Short Circuit Current Setting I2	xI1 (A)	6-9 in steps of 1	6-9 in steps of 1
Short Circuit Time Delay t2	mSec	25, 50, 100, 200	25, 50, 100, 200
Instantaneous Pick up Threshold	xI1 (A)	10 times	10 times
Ground Fault Current Ig (4-pole only)	xI1 (A)	0.1, 0.2, 0.3, 0.4, 0.5, 0.6, 0.7 (with function block feature)	
Ground Fault Trip Time Tg (4-pole only)	Sec	0.1, 0.2, 0.4, 0.6, 0.8, 1.0, 3.0, 5.0	
Field Test Switch		•	•
Auxiliary Power Module for Field Testing		•	•

• Available, + Supplied alongwith the MCCB above 63A
only one accessory can be fitted in the MCCB
© At 1.1 time In for max. 2 hours only

Technical Information

Standard conformity	:	IS/IEC 60947 – 2
Rated operational voltage	:	415V AC
Rated Insulation Voltage	:	750V AC
Type of release	:	Microprocessor Based Electronic Release
Utilisation Category	:	A
Rated frequency	:	50/60Hz
Operating altitude	:	2000 metres
Humidity	:	0 - 95%
Rated impulse voltage	:	8 kV



Frame		LES	LEN
No. of Poles			3P, 4P wSN
Standard Current Ratings, I_n	A		400, 630
Microprocessor Release	LSI	•	•
	LSIG	•	•
Rated S.C Making Capacity at 415 V lcm	kA	75.6	105
Rated Ultimate S.C Breaking Capacity (Icu), at	240 V	50	65
	415 V	36	50
	500 V	25	35
Rated Service S.C Breaking Capacity at 415 V Ics = % Icu	%	100%	75%
Weight	3P	kg	
	4P wSN	kg	
Terminal Capacity (Cable)	Sq. mm	1 x 240 (400A) 2 x 185 (630A)	1 x 240 (400A) 2 x 185 (630A)
	(Bus bar width)	mm	30
Overall Dimension (W x H x D)	TP	mm	140 x 254 x 110
	FP wSN	mm	186 x 254 x 110
Internal Accessories			
Auxiliary Switch (1 C/O or 2 C/O)		•	•
Shunt Trip		•	•
Under Voltage Release		•	•
Alarm Switch		•	•
External Accessories			
Rotary Handle - Extended		•	•
Extended Terminals		•	•
Dolly Extension		•	•
Phase Barriers		•	•
Terminal Shroud		•	•
Dolly Pad Locking Device		•	•
Earth Fault Relay		•	•
Characteristics of Microprocessor Release			
Overload Current, I_r	I_n (A)	0.4 – 1.0 in steps of 0.1	
Overload Time Delay, t_r	sec	3, 4, 6, 8, 10, 12, 16, 18	
Short Circuit Current Setting, I_s	I_r (A)	2, 2.5, 3, 4, 6	
Short Circuit Time Delay, t_s	sec	0.05, 0.1, 0.2, 0.3, 0.4, 0.6, 0.8, 1	
Instantaneous Short Circuit Current Setting, I_i	I_n (A)	2 – 8 in steps of 2	
Pre-Trip Indication, I_p	I_r	0.6, 0.7, 0.75, 0.8, 0.85, 0.9, 0.95, 1	
Ground Fault Current, I_g (in 4P wSN only)	I_n (A)	0.2 – 0.8 in steps of 0.1	

• Available

LSI - Long Delay, Short Delay & Instantaneous

LSIG - Long Delay, Short Delay, Instantaneous & Ground Fault

3P - Three Pole

4P wSN - Four Pole with Switched Neutral

FEN / FEH Frame Accessories

(Accessories are for 3P / 4P)

Alarm Switch



Voltage	Rating	Configuration	Cat. No.
125/250 VAC	1A	1NO + NC	IHLLALF1CO

Shunt Trip



Voltage	Cat. No.
100-110Vac	IHLLSTF110
220-240Vac	IHLLSTF240
380-415 Vac	IHLLSTF415

Note: Shunt Trip releases is provided with built-in auxiliary contact

Under Voltage Release

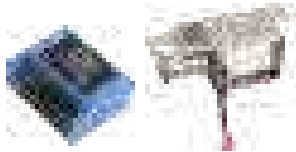

Voltage	Cat. No.
110-120 Vac	IHLUVRF110
220-240 Vac	IHLUVRF240
380-440 Vac	IHLUVRF440

The breaker trips if the supply voltage dips below 70%- 35% of the rated voltage.

The breaker cannot be switched ON unless there is a supply to the UVR. (NVNC feature).

Supplied with external mounting Power pack to operate on AC supplies. Additional transformer is supplied with LUVRF440 & LUVRF110.

Auxiliary Contact



Auxiliary Contact (250Vac / 250Vdc) (450Vac / 250Vdc)	
1. Change Over (1NO+1NC)	IHLLASF1CO
2. Change Over (2NO+2NC)	IHLLASF2CO

Rotary Handle



	Cat. No.
With Door interlock and 300mm remote shaft	IHLLRRHF30

Other Accessories



		Cat. No.
Dolly Pad locking device		IHLLDPF250
Phase Barriers	Three Pole	ISSLFX0036
	Four Pole	ISSLFX0038
Terminal Shrouds	Three Pole	IHLLTSFT00
	Four Pole	IHLLTSFF00
Extended terminals Up to 100 A	Three Pole	ISLFX0047
	Four Pole	ISLFX0044
Extended terminals 125 A - 250 A	Three Pole	ISLFX0049
	Four Pole	ISLFX0046

Field Test Unit



For Field testing of digital MCCB with 220 VAC supply

LES / LEN Frame Accessories

(Accessories are for 3P / 4P)

Alarm Switch

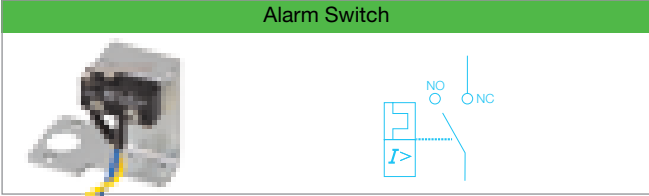

Voltage	Rating	Configuration	Cat. No.
240 VAC	1A	1NO + NC	IHLLB000

*Changeover Contact

Shunt Trip with Auxiliary switch

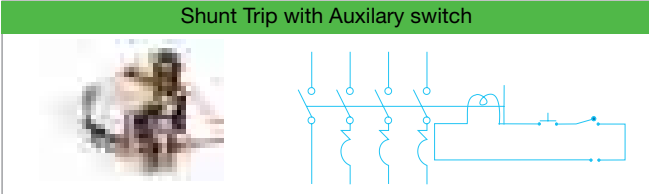

Voltage	Cat. No.
110Vac	IHLLS110
240Vac	IHLLS240
415 Vac	IHLLS415

Note: Shunt Trip releases is provided with built-in auxiliary contact

Under Voltage Release

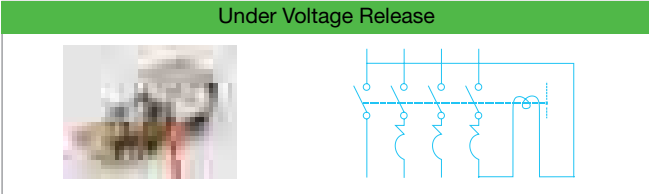

Voltage	Cat. No.
110	IHLLU110
220	IHLLU240
380	IHLLU415

Note: The breaker trips if the supply voltage dips below 70%- 35% of the rated voltage. The breaker cannot be switched ON unless there is a supply to the UVR. (NVNC feature). Supplied with external mounting Electronic Power pack to operate on AC supplies. Additional transformer is supplied with 415V & 110V UVR.

Auxiliary Contact

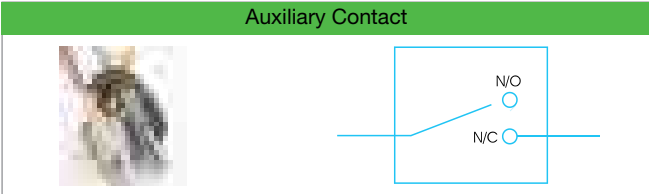

Voltage	Current Rating	*Configuration	Cat. No. (AC12)
250 Vac	4 A	1NO + 1NC	IHLLA1CO
250 Vac	4 A	2(1NO + 1NC)	IHLLA2CO

*Changeover Contact

Rotary Handle

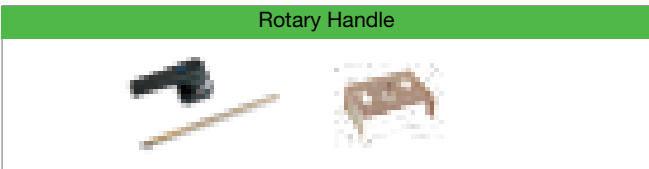

Rotary Handle	Cat. No.
With Door interlock and 300mm remote shaft	IHLLRN30

Dolly Pad Lock

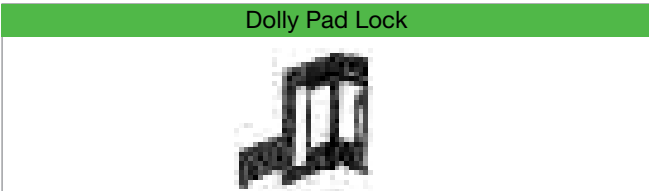

	Cat. No.
Dolly Extension	ISCPSSLX009
Dolly Pad locking device	IHLLP000

Other Accessories



	Cat. No. - 3P	Cat. No. - 4P
Dolly Pad locking device	IHLLDPF250	
Phase Barriers	ISSLFX0036	ISSLFX0038
Terminal Shrouds	IHLLTSFT00	IHLLTSFF00
Extended terminals Up to 100 A	ISLFX0047	ISLFX0044
Extended terminals 125 A - 250 A	ISLFX0049	ISLFX0046

Field Test Unit

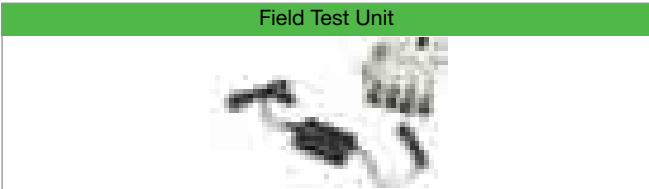

For Field testing of digital MCCB with 220 VAC supply

Ordering Information



FE Frame Three Pole MCCB		
Current Rating (A)	Icu 35kA Cat. No.	Icu 50kA Cat. No.
25	IHLFENT0025	IHLFEHT0025
40	IHLFENT0040	IHLFEHT0040
63	IHLFENT0063	IHLFEHT0063
100	IHLFENT0100	IHLFEHT0100
125	IHLFENT0125	IHLFEHT0125
160	IHLFENT0160	IHLFEHT0160
200	IHLFENT0200	IHLFEHT0200
250	IHLFENT0250	IHLFEHT0250



FE Frame Four Pole MCCB		
Current Rating (A)	Icu 35kA Cat. No.	Icu 50kA Cat. No.
25	IHLFENF0025	IHLFEHF0025
40	IHLFENF0040	IHLFEHF0040
63	IHLFENF0063	IHLFEHF0063
100	IHLFENF0100	IHLFEHF0100
125	IHLFENF0125	IHLFEHF0125
160	IHLFENF0160	IHLFEHF0160
200	IHLFENF0200	IHLFEHF0200
250	IHLFENF0250	IHLFEHF0250



LE Frame TP MCCB		
Current Rating (A)	Icu 36 kA Cat No.	Icu 50 kA Cat No.
250	IHLLSEET0250	IHLLNFET0250
320	IHLLSEET0320	IHLLNFET0320
400	IHLLSEET0400	IHLLNFET0400
500	IHLLSEET0500	IHLLNFET0500
630	IHLLSEET0630	IHLLNFET0630



LE Frame FP wSN MCCB		
Current Rating (A)	Icu 36 kA Cat No.	Icu 50 kA Cat No.
250	IHLLSEEF0250	IHLLNFEF0250
320	IHLLSEEF0320	IHLLNFEF0320
400	IHLLSEEF0400	IHLLNFEF0400
500	IHLLSEEF0500	IHLLNFEF0500
630	IHLLSEEF0630	IHLLNFEF0630

Time Current Characteristics - FEN / FEH Frame

Ground Fault & Over Current Tripping Characteristics

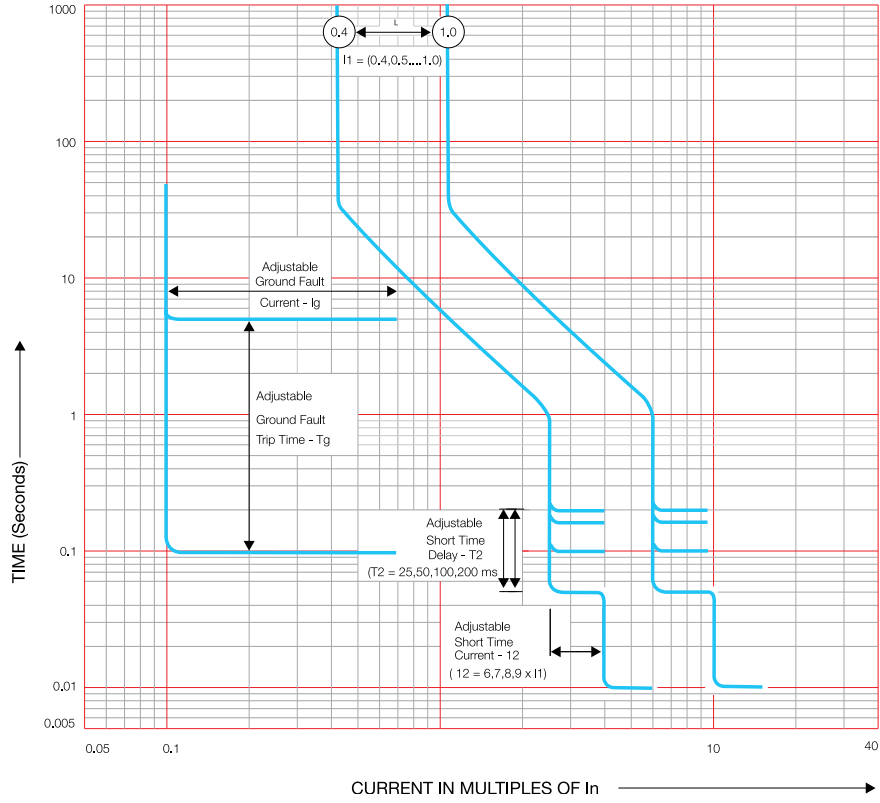

Time Current Characteristics - LES / LEN Frame

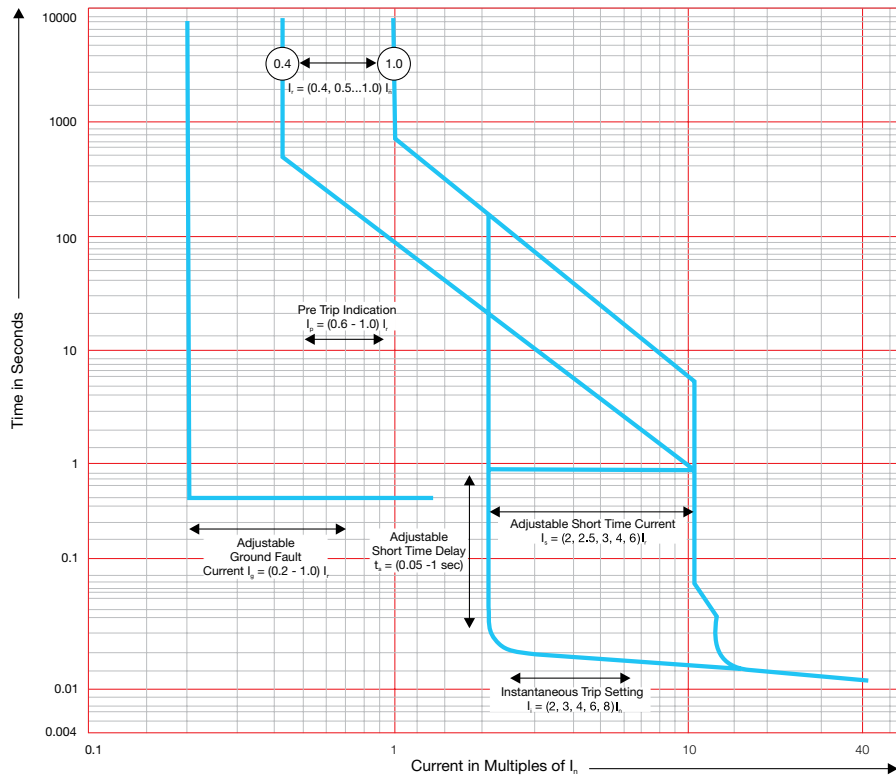

Dimensions (in mm)

F Frame - Four Pole With Extended Terminal

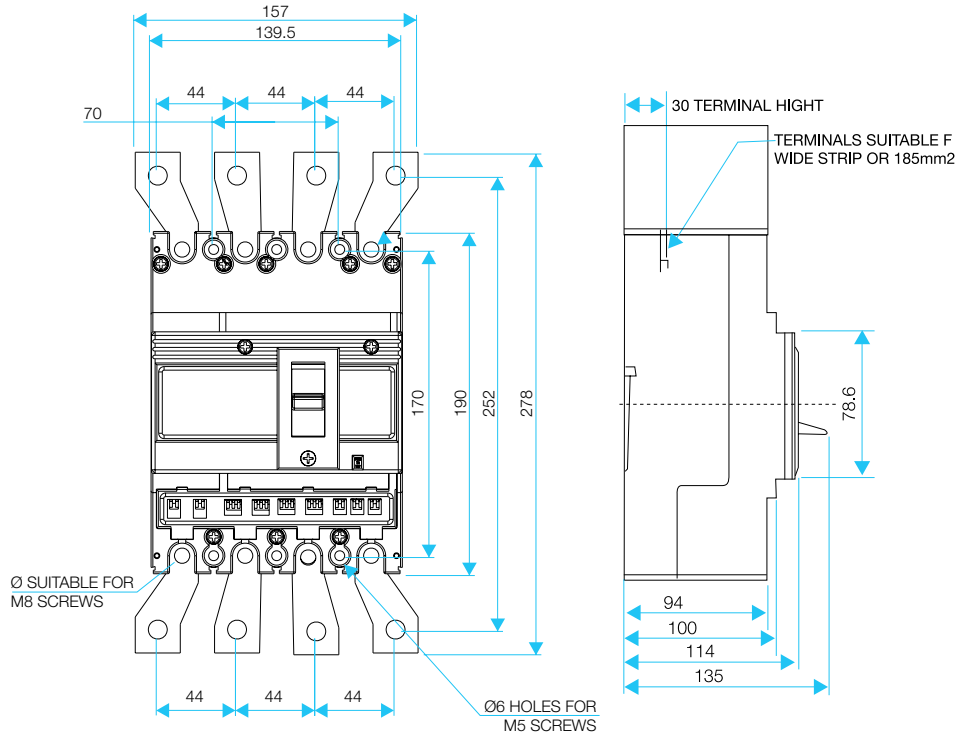

Dimensions (in mm)

F Frame - Three Pole With Extended Terminal

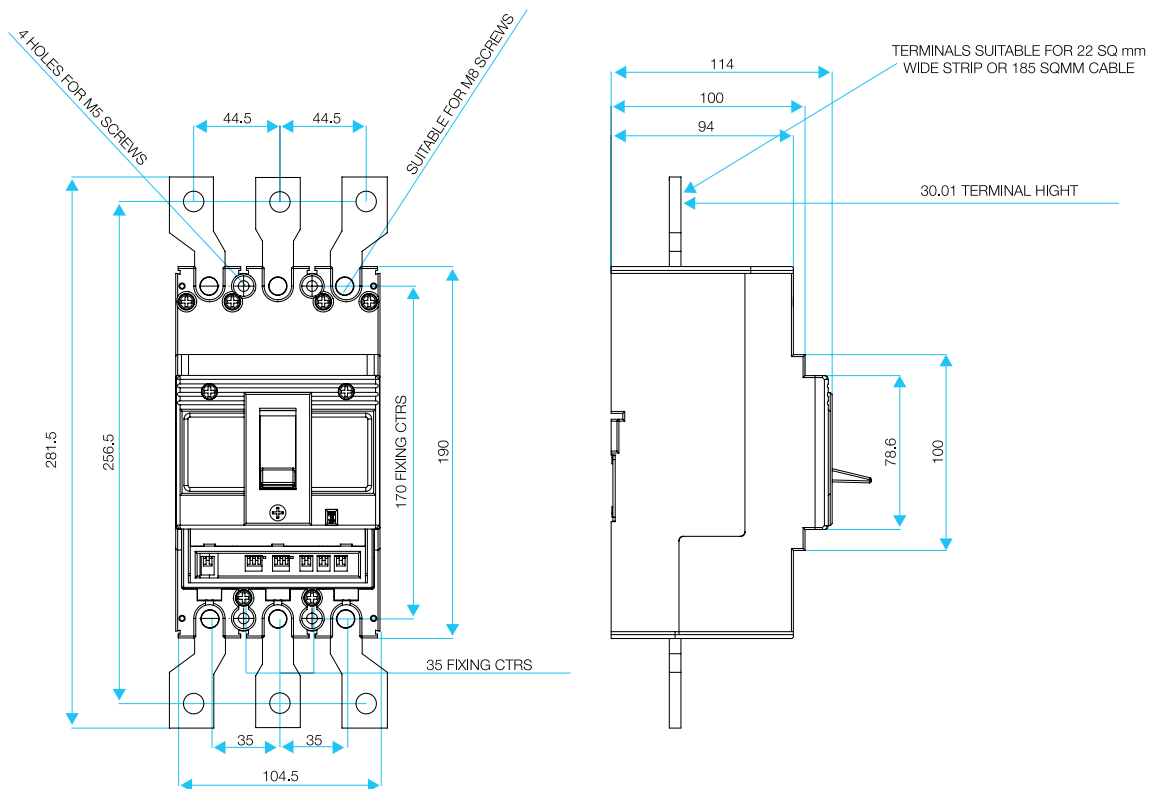

L Frame - Three Pole with extended terminals

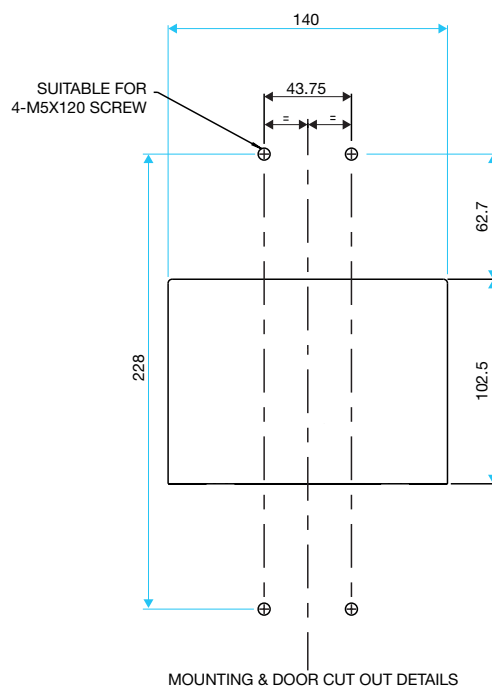
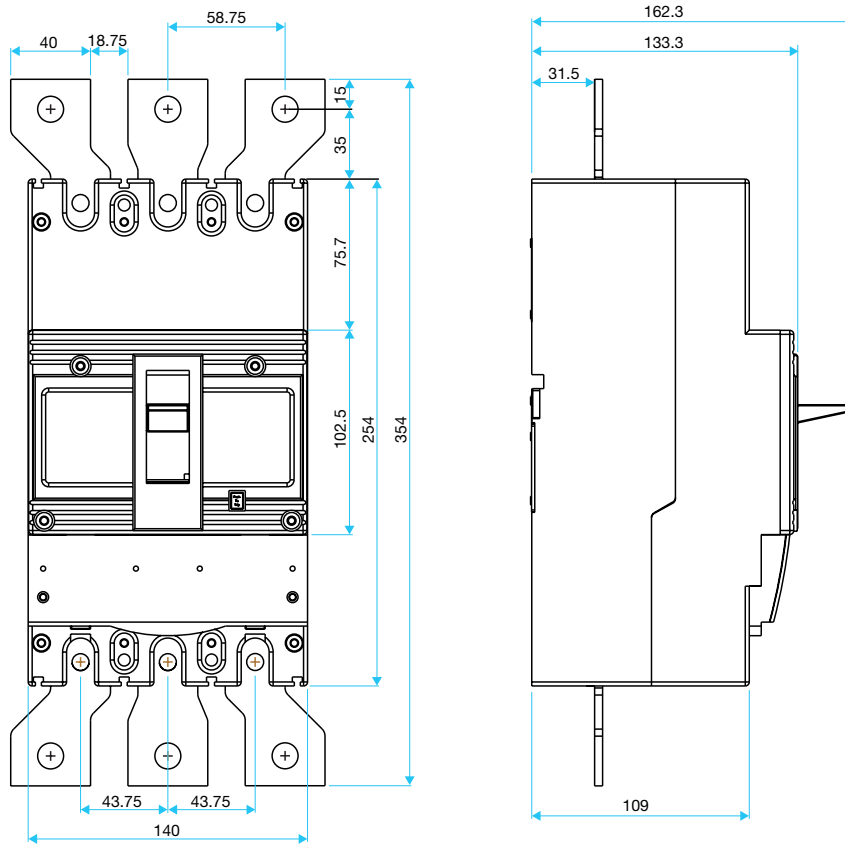

Dimensions (in mm)

L Frame - FP wSN with extended terminals

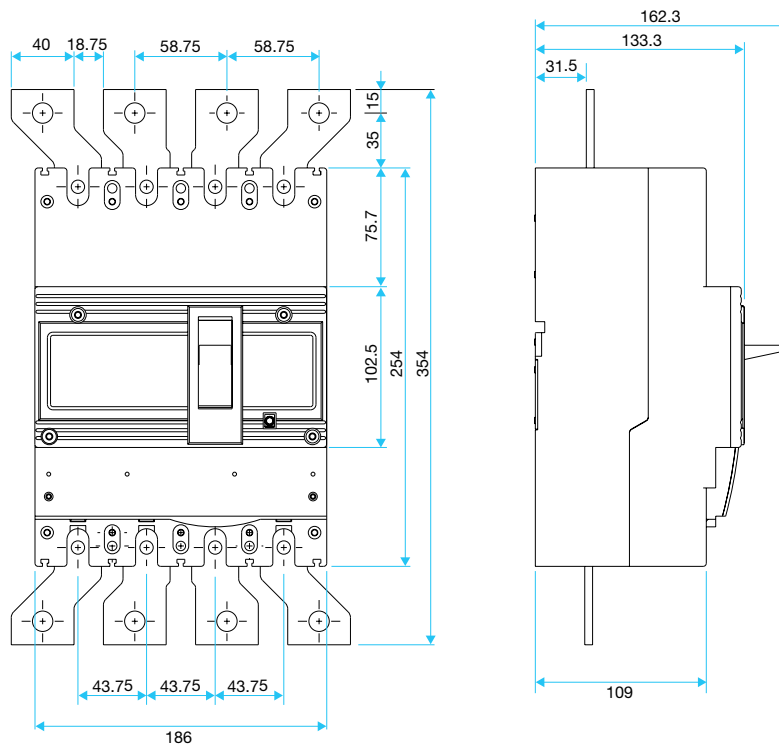

SUITABLE FOR
6-M5X120 SCREW

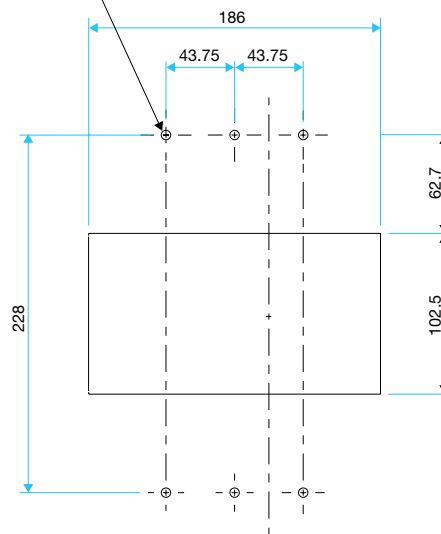

MOUNTING & DOOR CUT OUT DETAILS

MCCB Panel Board System

Features:

- CE Certified
- Ready made & customised solutions for load management
- Modular construction & compact size provides economy of space, time & cost.
- Designed for floor mounting / wall mounting
- Specially designed shrouded busbar provides safety
- No. of ways option permits future system expansion
- Easy add on modules to house various devices offers simplicity & flexibility
- Elegant & sleek in appearance.

Range :

Two basic versions :

- 'G' frame panel boards upto 400A
- 'A' frame panel boards upto 800A

Specification :

- Fully application oriented as per
- IS / IEC: 60947-1&II
- IS / IEC: 61439-3
- IS / IEC: 60529

Loadbank is a power distribution board with MCCBs as incoming and outgoing switching-cum-protective devices, for distribution of power to various loads as per the requirements of the system.

The modular construction of load bank renders the customary panel building redundant by virtue of compactness, reduced cost and short delivery time coupled with reliability of the various modular units. All units are fabricated using sheet steel of 1.6mm and are epoxy powder coated to give a superior finish.



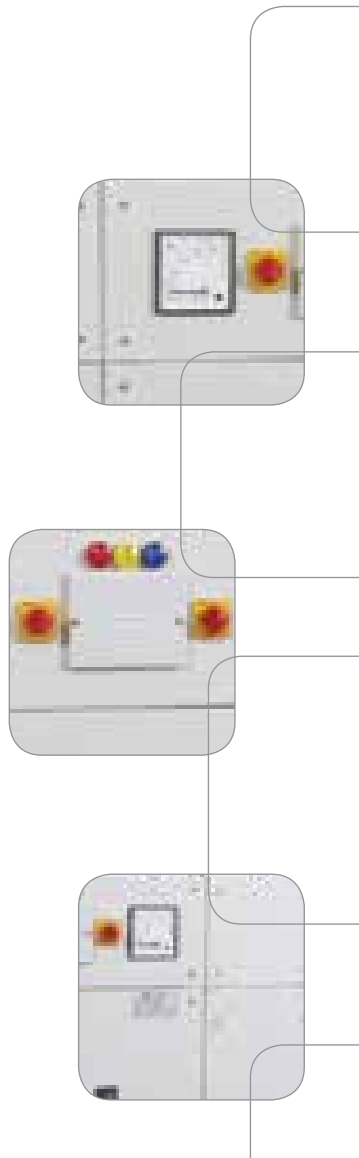

Construction

172



Loadbank Panel Boards have a unique modular construction with incoming & outgoing MCCBs housed in an enclosure forming the basic module. Cable way module, metering module and MCB module have to be added to the basic module to have a complete loadbank system to suit the specific requirement.

Basic Module

The basic module comprises of two sections, namely :

Incoming Module

The incoming module accommodates single MCCBs upto 400A in G frame panel boards and upto 800A in A Frame panel boards. They are all supplied with their own dedicated set of preformed copper interconnections.

Outgoing Module

They are available with 2, 4, 6, 8, 12 or 16 way outgoing circuits suitable for mounting single pole or three pole 'G' Frame MCCBs upto 125A in 'G' frame panel boards and for mounting single pole and three pole 'A' frame MCCBs upto 250A in 'A' frame panel boards. The bus bars are fully rated and are completely shielded by transparent polycarbonate shrouds with the extension tags and metal shielding removed from one end. Adequate space is provided for terminating the cable onto the MCCBs.



Cable Way Module

Cableways can be added on either side of the basic module for termination of incoming & outgoing MCCBs. The cable way selection is simply determined by adding together the modular height of the final layout & choosing cableways to match. The vertical insulated partition kit allows shielding between the shared face of a cableway and the basic module.

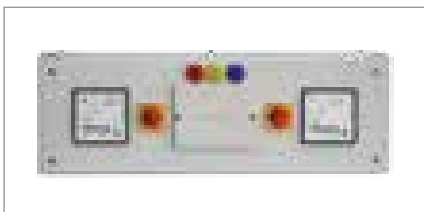

Metering Module

This module can be assembled on top of the basic module. Two types of metering module are available, namely, analog and digital. The analog type metering module comprises of analog type ammeter and voltmeter, whereas, the digital type metering module comprises of digital type ammeter and voltmeter. Besides ammeter and voltmeter, the metering module is provided with selector switches, indicating lights and back up fuses.



MCB Module

A module for housing MCBs can be integrated with the loadbanks for individual final outgoing circuit protection. Two different versions are available for mounting 22 SPMCBs or 24 SPMCBs on DIN channel.

Add on Module

The add on module is designed for giving extra space for incoming termination. This module can be assembled at the bottom of the basic module.

Technical Information



G Frame Panel Board		
Ref. Standard	IS: / IEC: 61439 - 3	
Incoming		
MCCB Rating	A Frame upto 250A	C Frame upto 400A
No. of Poles	TP, FP	TP, FP
Breaking Capacity (KA)	25	35, 50
Outgoing		
No. of ways	2, 4, 6, 8, 12, 16	2, 4, 6, 8, 12, 16
MCCB Rating	G Frame upto 160A	G Frame upto 160A
Breaking Capacity (KA)	10, 16, 25	10,16,25
Bus Bar Rating	250A	400A
Short time withstand current	30KA for 1 sec	30KA for 1 sec
Neutral terminal capacity	upto 70 sq.mm	
Enclosure material / thickness	CRCA sheet steel / 1.6mm	
Mounting	Floor / wall mount	
Degree of protection	IP 30	

A Frame Panel Board		
Ref. Standard	IS: / IEC: 61439 - 3	
Incoming		
MCCB Rating	C Frame upto 400A	C Frame upto 800A
No. of Poles	TP, FP	TP, FP
Breaking Capacity (KA)	35, 50	35, 50
Outgoing		
No. of ways	6, 8, 12	6, 8, 12
MCCB Rating	A Frame upto 250A	A Frame upto 250A
Breaking Capacity (KA)	16, 25	16, 25
Bus Bar Rating	400A	630A
Short time withstand current	30KA for 1 sec	50KA for 1 sec
Neutral terminal capacity	upto 70 sq.mm	
Enclosure material / thickness	CRCA sheet steel / 1.6mm	
Mounting	Floor / wall mount	
Degree of protection	IP 30	



Load Bank Enclosure

Suitable for
Three Pole
outgoing MCCB

'G' Frame Panel Board, O/G TP MCCBs G-Frame		
Current Rating (A) Incomer	Outgoing* (No. of ways)	Cat. No.
	2	IHBG025002
250A	4	IHBG025004
"AA" Frame	6	IHBG025006
MCCB	8	IHBG025008
	12	IHBG025012
	16	IHBG040016

Suitable for
Three Pole
outgoing MCCB

'G' Frame Panel Board, O/G TP MCCBs G-Frame		
Current Rating (A) Incomer	Outgoing* (No. of ways)	Cat. No.
	2	IHBG040002
400A	4	IHBG040004
"CN" Frame	6	IHBG040006
MCCB	8	IHBG040008
	12	IHBG040012
	16	IHBG040016

Suitable for
Four Pole
outgoing MCCB

'G' Frame Panel Boards, O/G FP MCCBs G-Frame		
Current Rating (A) Incomer	Outgoing* (No. of ways)	Cat. No.
	2	IHBGF25002
250A	4	IHBGF25004
"AA" Frame	6	IHBGF25006
MCCB	8	IHBGF25008
	12	IHBGF25012

Suitable for
Four Pole
outgoing MCCB

'G' Frame Panel Boards, O/G FP MCCBs G-Frame		
Current Rating (A) Incomer	Outgoing* (No. of ways)	Cat. No.
	2	IHBGF40002
400A	4	IHBGF40004
"CN" Frame	6	IHBGF40006
MCCB	8	IHBGF40008
	12	IHBGF40012

* The outgoings number of ways is the number of "G" Frame TP/FP MCCBs that can be mounted. In case of SP MCCBs the number of MCCBs shall be three times the number of ways in TP and four times the number of way in FP O/G.

** Maximum ratings are indicated for the incoming MCCBs however lower ratings in the same frame can be ordered.

Load Bank Enclosure



'G' Frame Panel Board - Cable Alley		
Outgoing TP MCCB, Incomer 'A' & 'C' Frame MCCB		
S. No.	Description	Cat. No.
1	Cable Alley 2WAY I/C 250A	IHBGCA02
2	Cable Alley 4WAY I/C 250A / 2WAY I/C 400A	IHBGCA04
3	Cable Alley 6W I/C 250A / 4W I/C 400A	IHBGCA06
4	Cable Alley 8WAY I/C 250A	IHBGCA08
5	Cable Alley 12WAY I/C 250A / 6 & 8WAY I/C 400A	IHBGCA12
6	Cable Alley 16WAY I/C 250A / 12WAY I/C 400A	IHBGCA16
7	Cable Alley 16WAY I/C 400A	IHBGCA46

* Each set of Cable Alley consists of two numbers, one each on LHS and RHS.

'G' Frame Panel Board - Cable Alley		
Outgoing FP MCCB, Incomer 'A' & 'C' Frame MCCB		
S. No.	Description	Cat. No.
1	Cable Alley 2WAY I/C 250A	IHBGFCA02
2	Cable Alley 4WAY I/C 250A / 2WAY I/C 400A	IHBGFCA04
3	Cable Alley 6WAY I/C 250A / 4WAY I/C 400A	IHBGFCA06
4	Cable Alley 8WAY I/C 250A / 6WAY I/C 400A	IHBGFCA08
5	Cable Alley 12WAY I/C 250A/ 8WAY I/C 400A	IHBGFCA12
6	Cable Alley 12WAY I/C 400A	IHBGFCA42

* Each set of Cable Alley consists of two numbers, one each on LHS and RHS.

'G' Frame Panel Board Bare Meter Module / MCB Module / Add on Module	
Description*	Cat. No.
Meter Module - Analog Provision for Ammeter, Voltmeter - Analog with selector switch	IHBGMA00
Meter Module - Digital Provision for Ammeter, Voltmeter - Digital with selector switch	IHBGMD00
MCB Module	IHBGMC00
Add on Module	IHBGAM00

* Ammeter, Voltmeter, Selector Switch, Control Fuses, Indicating Lights, MCBs etc. have to be ordered separately and are at extra cost.

** The above prices are for bare module enclosures only.

'G' Frame Panel Boards Pre-Wired Meter Module with Voltmeter, Ammeter, Selector Switch, Ct's Control Fuse & Indicating Lights	
Description*	Cat. No.
Meter Module - Analog	IHBGMW00
Meter Module - Digital	IHBGDW00



Load Bank Enclosure

Suitable for Three Pole outgoing MCCB

'A' Frame Panel Board, O/G TP MCCBs		
Current Rating (A) Incomer	Outgoing* (No. of ways)	Cat. No.
400A	6	IHBA040006
"CN/CH" Frame	8	IHBA040008
MCCB	12	IHBA040012

Suitable for Three Pole outgoing MCCB

'A' Frame Panel Board, O/G TP MCCBs		
Current Rating (A) Incomer	Outgoing* (No. of ways)	Cat. No.
800A	6	IHBA080006
"CN/CH" Frame	8	IHBA080008
MCCB	12	IHBA080012

* The outgoing number of ways is the number of "A" Frame TP MCCBs that can be mounted.
 ** Maximum ratings are indicated for the incoming MCCBs however lower ratings in the same frame can be ordered.

'A' Frame Panel Board - Cable Alley	
I/C 400A 'C' Frame MCCB	
Description	Cat. No.
Cable Alley 6WAY 400A IC	IHBACA06
Cable Alley 8WAY 400A IC	IHBACA08
Cable Alley 12WAY 400A IC	IHBACA12

* Each set of Cable Alley consists of two numbers, one each on LHS and RHS.

'A' Frame Panel Board - Cable Alley	
I/C 800A 'C' Frame MCCB	
Description	Cat. No.
Cable Alley 6WAY 800A IC	IHBBCA06
Cable Alley 8WAY 800A IC	IHBBCA08
Cable Alley 12WAY 800A IC	IHBBCA12

* Each set of Cable Alley consists of two numbers, one each on LHS and RHS.

'A' Frame Panel Board Bare Meter Module / MCB Module / Add on Module	
Description*	Cat. No.
Meter Module - Analog Provision for Ammeter, Voltmeter - Analog with selector switch	IHBAMA00
Meter Module - Digital Provision for Ammeter, Voltmeter - Digital with selector switch	IHBAMD00
MCB Module	IHBAMC00
Add on Module	IHBAAM00

* Ammeter, Voltmeter, Selector Switch, Control Fuses, Indicating Lights, MCBs etc. have to be ordered separately and are at extra cost.

'A' Frame Panel Boards Pre-wired Meter Module with Voltmeter, Ammeter, Selector Switch CT's, Control Fuse & Indicating Lights	
Description*	Cat. No.
Meter Module - Analog	IHBAMW00
Meter Module - Digital	IHBADW00

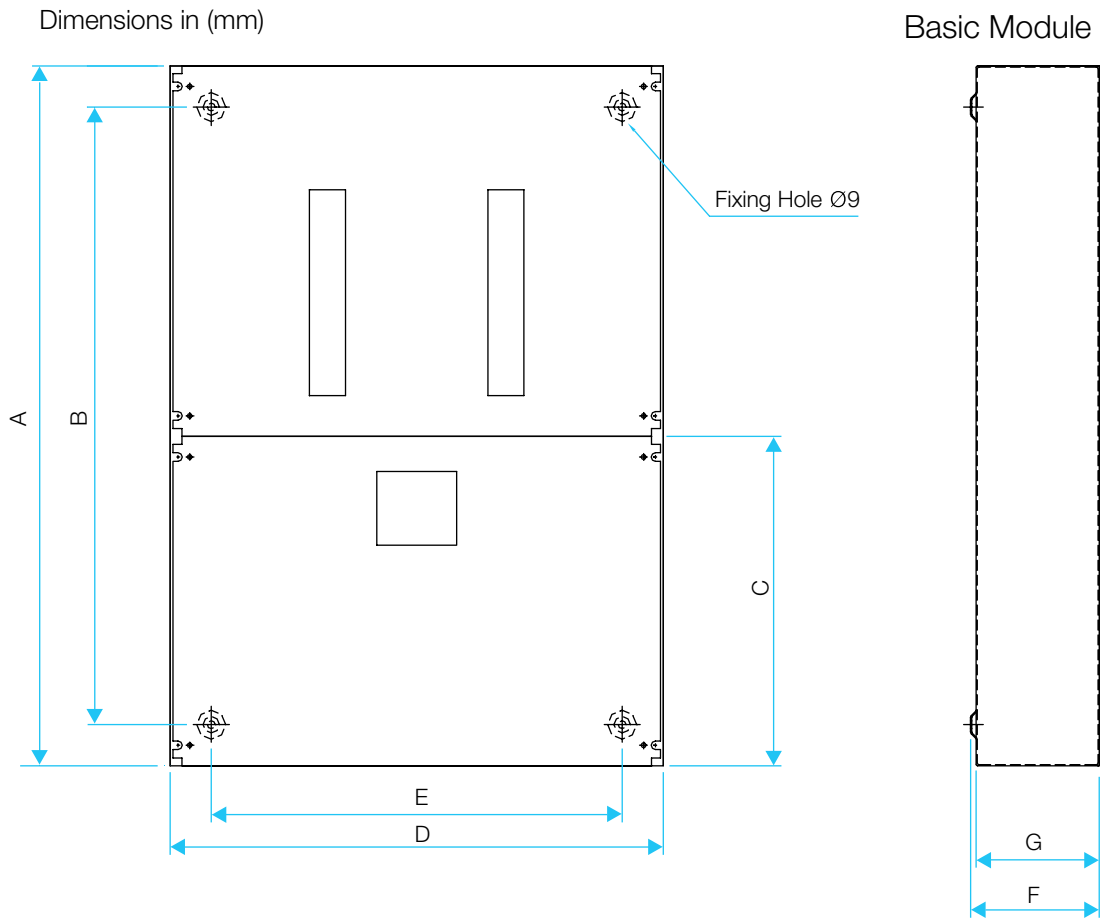

S. No.	Incoming	Outgoing	Type	Size	Height (A)	Height CD (B)	(C)	Length (D)	Length CD (E)	(F)	Width (G)
1	A-Frame Incomer 3P/4P (UP TO 250 A)	G-Frame 3P outgoing	2 WAY	630	525	420	630	525	165	160	
			4 WAY	734	629	420	630	525	165	160	
			6 WAY	893	788	420	630	525	165	160	
			8 WAY	893	788	420	630	525	165	160	
			12 WAY	1050	945	420	630	525	165	160	
2	A-Frame Incomer 3P/4P (UP TO 250 A)	G-Frame 4P outgoing	2 WAY	630	525	420	630	525	165	160	
			4 WAY	734	629	420	630	525	165	160	
			6 WAY	893	788	420	630	525	165	160	
			8 WAY	1050	945	420	630	525	165	160	
			12 WAY	1207	1102	420	630	525	165	160	
3	C-Frame 3P/4P Incomer (UP TO 400 A)	G-Frame 3P outgoing	2 WAY	734	629	577.5	630	525	165	160	
			4 WAY	893	788	577.5	630	525	165	160	
			6 WAY	1050	945	577.5	630	525	165	160	
			8 WAY	1050	945	577.5	630	525	165	160	
			12 WAY	1207	1102	577.5	630	525	165	160	
4	C-Frame 3P/4P Incomer (UP TO 400 A)	G-Frame 4P outgoing	2 WAY	734	629	577.5	630	525	165	160	
			4 WAY	893	788	577.5	630	525	165	160	
			6 WAY	1050	945	577.5	630	525	165	160	
			8 WAY	1207	1102	577.5	630	525	165	160	
			12 WAY	1360	1255	577.5	630	525	165	160	
5	C-Frame 3P/4P Incomer(UP TO 400 A)	A-Frame 3P OUTGOING	6 WAY	1220	990	762	750	650	206	200	
			8 WAY	1220	990	762	750	650	206	200	
			12 WAY	1370	1140	762	750	650	206	200	
6	C-Frame 3P/4P Incomer(UP TO 800 A)	A-Frame 3P OUTGOING	6 WAY	1370	1140	915	750	650	206	200	
			8 WAY	1370	1140	915	750	650	206	200	
			12 WAY	1523	1293	915	750	650	206	200	

Dimensions (in mm) - Cable Alley

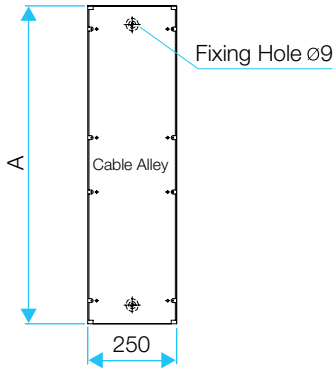

G Frame Panel Boards - A Frame Incomer

Modules	Height (A)	
	250A Incomer	400A Incomer
1 way	210	210
2 way	630	734
4 way	734	893
6 way	893	1050
8 way	893	1050
12 way	1050	1207
16 way	1207	1360

Dimensions (in mm) - Meter Module / Mcb Module / Add-on Module

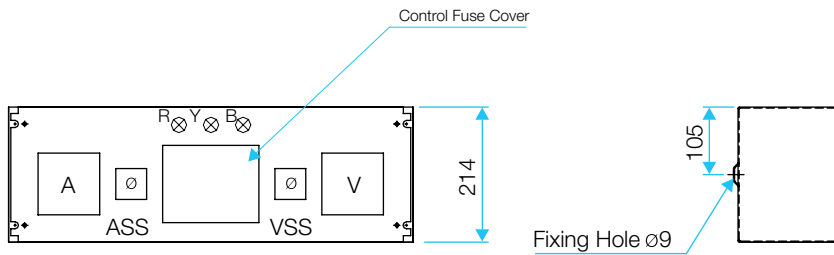

G Frame Panel Boards - 250A / 400A
(A/C Frame incomer, G Frame outgoing)

Same for TP & FP

Dimensions (in mm) - Cable Alley

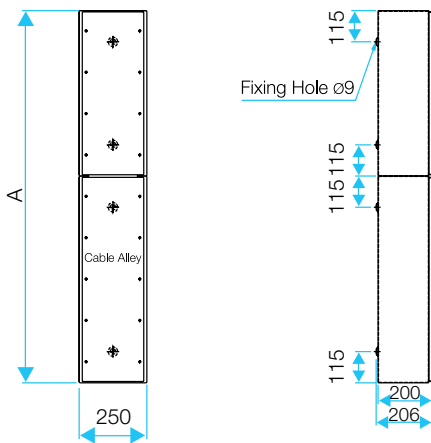

A Frame Panel Boards - C Frame Incomer

Modules	Height (A)	
	400A Incomer	800A Incomer
6 way	1220	1370
8 way	1220	1370
12 way	1370	1523

Dimensions (in mm) - Meter Module / Mcb Module / Add-on Module

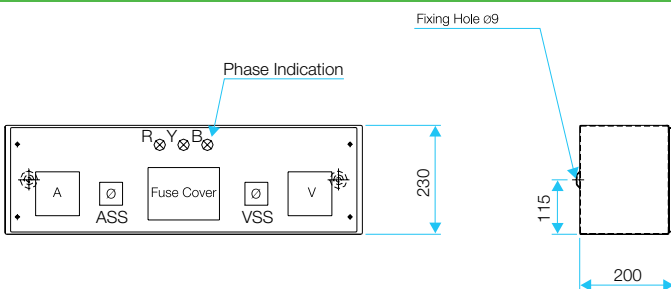

G Frame Panel Boards - 250A / 400A
(A/C Frame incomer, G Frame outgoing)

Same for TP & FP

POWERSAFE Panel Board

NEW

Havells introduces a new range of MCCB Panelboards for Electrical supplies from 250A – 800A. In addition to managing safe Electrical Distribution, the range reflects the wider peripheral demands within modern Commercial buildings installations and upgrades, addressing application requirements such as metering. With an ever increasing focus on energy management and monitoring, the MCCB Panelboards have been designed to simplify the installation of metering for both incoming and outgoing supplies. Outgoing MCCB's for current ratings up to 160A are available for Panelboards up to 400A. The 800A Panelboards provide options for outgoing circuits up to 250A.

This range is available in double door version. It also has a provision to install a changeover switch as an Incomer.



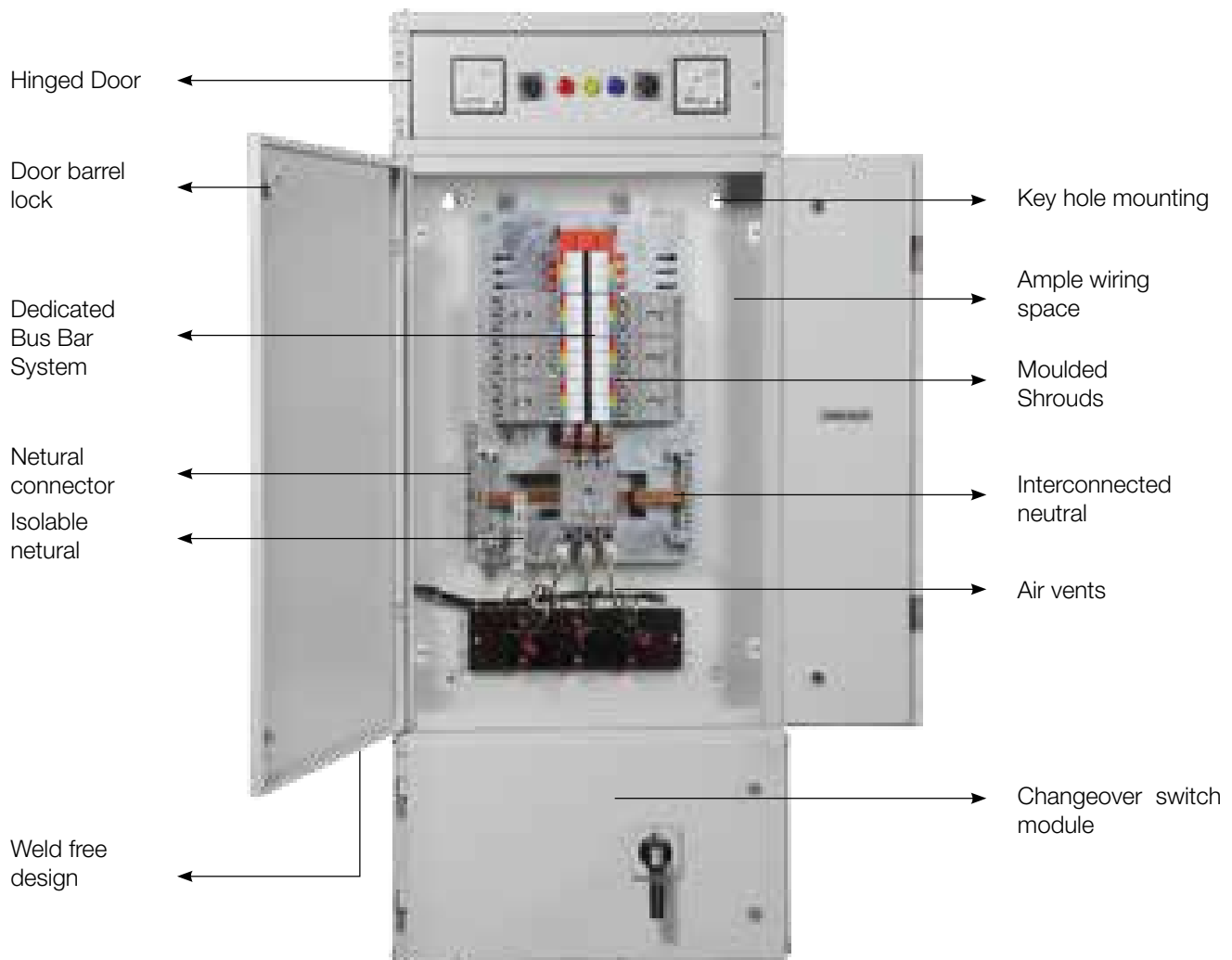

Quality Features

- Available in Single door and Double door
- Aesthetic layout
- Door opening to 180° for easy access
- Robust 1.6mm gland plates are removable to aid installation
- Rigid & weld free construction to reduce distortion
- Removable door with easy align hinge to aid installation
- Chrome plated hinges
- Door barrel lock accessory for increased security
- Powder coated paint for better environment protection
- Cable holder provision in cable alley
- Key hole mounting
- Ingress protection, IP 30 for single door and double door



Basic Module

This accommodates single MCCBs upto 400A in G frame panel boards and upto 800A in A Frame panel boards. They are all supplied with their own dedicated set of preformed copper interconnections. It has provision for 2, 4, 6, 8, 12 & 16 way outgoing circuits suitable for mounting single pole, or three pole or four pole 'G' Frame MCCBs upto 160A in 'G' frame panel boards and for mounting three pole 'A' frame MCCBs upto 250A in 'A' frame panel boards. The bus bar system are fully rated and are completely shielded all around by nylon robust shrouds having proper air vents. Adequate space is provided for terminating the cable onto the MCCBs.

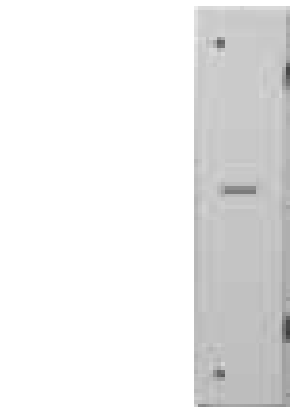

Cable Way Module

Cableway can be added on either side of the basic module for termination of incoming & outgoing MCCBs. The cable way selection is simply determined by adding together the modular height of the final layout & choosing cableways to match. The vertical insulated partition kit allows shielding between the shared face of a cableway and the basic module.

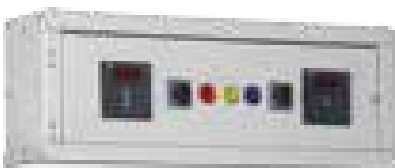

Metering Module

This module can be assembled on top of the basic module. Two types of metering module are available, namely, analog and digital. The analog type metering module comprises of analog type ammeter and voltmeter, whereas, the digital type metering module comprises of digital type ammeter and voltmeter. Besides ammeter and voltmeter, the metering module is provided with selector switches, indicating lights and back up fuses.

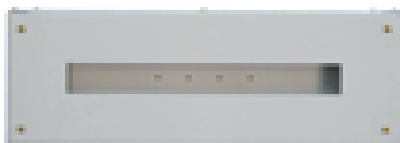

MCB Module

A module for housing MCBs can be integrated with the panel board for individual final outgoing circuit protection. Two different versions are available for mounting 22 SPMCBs or 24 SPMCBs on DIN channel.



Add on Module

The add on module is designed for giving extra space for incoming termination. This module can be assembled at the bottom of the basic module if required.

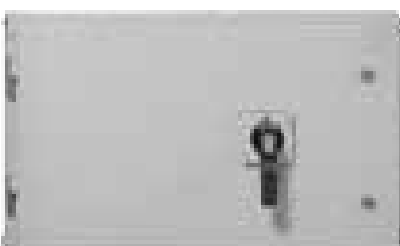

Add on Changeover switch module

This module houses the changeover switch for main / standby supply integration. It is available in 250A, 400A, 630A & 800A.

Technical Information:



G Frame Panel Board		
Ref. Standard	IS: / IEC: 61439 - 3	
Incoming		
MCCB Rating	A Frame upto 250A	C Frame upto 400A
No. of Poles	TP, FP	TP, FP
Breaking Capacity (KA)	25	35, 50
Outgoing		
No. of ways	2, 4, 6, 8, 12, 16	2, 4, 6, 8, 12, 16
MCCB Rating	G Frame upto 160A	G Frame upto 160A
Breaking Capacity (KA)	10, 16, 25	10, 16, 25
Bus Bar Rating	250A	400A
Short time withstand current	30KA for 1 sec	30KA for 1 sec
Neutral terminal capacity	upto 70 sq.mm	
Enclosure material / thickness	CRCA sheet steel / 1.6mm	
Mounting	Floor / wall mount	
Degree of protection	IP 30	



A Frame Panel Board		
Ref. Standard	IS: / IEC: 61439 - 3	
Incoming		
MCCB Rating	C Frame upto 400A, 630A	C Frame upto 800A
No. of Poles	TP, FP	TP, FP
Breaking Capacity (KA)	35, 50	35, 50
Outgoing		
No. of ways	6, 8, 12	6, 8, 12
MCCB Rating	A Frame upto 250A	A Frame upto 250A
Breaking Capacity (KA)	16, 25	16, 25
Bus Bar Rating	400A	800A
Short time withstand current	30KA for 1 sec	50KA for 1 sec
Neutral terminal capacity	upto 70 sq.mm	
Enclosure material / thickness	CRCA sheet steel / 1.6mm	
Mounting	Floor / wall mount	
Degree of protection	IP 30	



PowerSafe Enclosure

Suitable for
Three Pole
outgoing MCCB

'G' Frame Panel Board, O/G TP MCCBs G-Frame			
Current Rating (A) Incomer	Outgoing* (No. of ways)	Single Door Cat. No.	Double Door Cat. No.
	2	IHVG025002	IHVG02500200
250A	4	IHVG025004	IHVG02500400
"AA" Frame	6	IHVG025006	IHVG02500600
MCCB	8	IHVG025008	IHVG02500800
	12	IHVG025012	IHVG02501200
	16	IHVG025016	IHVG02501600

Suitable for
Three Pole
outgoing MCCB

'G' Frame Panel Board, O/G TP MCCBs G-Frame			
Current Rating (A) Incomer	Outgoing* (No. of ways)	Single Door Cat. No.	Double Door Cat. No.
	2	IHVG040002	IHVG04000200
400A	4	IHVG040004	IHVG04000400
"CN" Frame	6	IHVG040006	IHVG04000600
MCCB	8	IHVG040008	IHVG04000800
	12	IHVG040012	IHVG04001200
	16	IHVG040016	IHVG04001600

Suitable for
Four Pole
outgoing MCCB

'G' Frame Panel Boards, O/G FP MCCBs G-Frame			
Current Rating (A) Incomer	Outgoing* (No. of ways)	Single Door Cat. No.	Double Door Cat. No.
	2	IHVGF25002	IHVGF2500200
250A	4	IHVGF25004	IHVGF2500400
"AA" Frame	6	IHVGF25006	IHVGF2500600
MCCB	8	IHVGF25008	IHVGF2500800
	12	IHVGF25012	IHVGF2501200

Suitable for
Four Pole
outgoing MCCB

'G' Frame Panel Boards, O/G FP MCCBs G-Frame			
Current Rating (A) Incomer	Outgoing* (No. of ways)	Single Door Cat. No.	Double Door Cat. No.
	2	IHVGF40002	IHVGF4000200
400A	4	IHVGF40004	IHVGF4000400
"CN" Frame	6	IHVGF40006	IHVGF4000600
MCCB	8	IHVGF40008	IHVGF4000800
	12	IHVGF40012	IHVGF4001200

* The outgoing number of ways is the number of "G" Frame TP/FP MCCBs that can be mounted. In case of SP MCCBs the number of MCCBs shall be three times the number of ways in TP and four times the number of way in FP O/G.

** Maximum ratings are indicated for the incoming MCCBs however lower ratings in the same frame can be ordered.



PowerSafe Enclosure

'A' Frame Panel Board, O/G TP MCCBs			
Current Rating (A) Incomer	Outgoing* (No. of ways)	Single Door Cat. No.	Doble Door Cat. No.
400A	6	IHVA040006	IHVA04000600
"CN/CH" Frame	8	IHVA040008	IHVA04000800
MCCB	12	IHVA040012	IHVA04001200

'A' Frame Panel Board, O/G TP MCCBs			
Current Rating (A) Incomer	Outgoing* (No. of ways)	Single Door Cat. No.	Doble Door Cat. No.
630A	6	IHVA063006	IHVA06300600
"CN/CH" Frame	8	IHVA063008	IHVA06300800
MCCB	12	IHVA063012	IHVA06301200

'A' Frame Panel Board, O/G TP MCCBs			
Current Rating (A) Incomer	Outgoing* (No. of ways)	Single Door Cat. No.	Doble Door Cat. No.
800A	6	IHVA080006	IHVA08000600
"CN/CH" Frame	8	IHVA080008	IHVA08000800
MCCB	12	IHVA080012	IHVA08001200



PowerSafe Cable Alley

'G' Frame Panel Board - Cable Alley			
Incomer 250A, outgoing TP / FP G Frame MCCBs			
S. No.	Description	Single Door Cat. No.	Double Door Cat. No.
1	Cable Alley I/C 250A,O/G 3P GF 2/4 Way	ISSBOU0674	ISSBOU0690
2	Cable Alley I/C 250A,O/G 3P GF 6 Way & 4P 2/4 Way	ISSBOU0675	ISSBOU0691
3	Cable Alley I/C 250A,O/G 3P GF 8 Way & 4P 6 Way	ISSBOU0676	ISSBOU0692
4	Cable Alley I/C 250A,O/G 3P GF 12 Way	ISSBOU0677	ISSBOU0693
5	Cable Alley I/C 250A,O/G 4P GF 8 Way	ISSBOU0678	ISSBOU0694
6	Cable Alley I/C 250A,O/G 3P GF 16 Way & 4P 12 Way	ISSBOU0679	ISSBOU0696

* Each set of Cable Alley consists of two numbers, one each on LHS and RHS.

'G' Frame & 'A' Frame Panel Board - Cable Alley			
Incomer 400A, outgoing TP / FP G Frame / A Frame MCCBs			
S. No.	Description	Single Door Cat. No.	Double Door Cat. No.
1	Cable Alley I/C 400A,O/G 3P GF 2/4 Way	ISSBOU0680	ISSBOU0697
2	Cable Alley I/C 400A,O/G 3P GF 6 Way & 4P 2/4 Way	ISSBOU0681	ISSBOU0698
3	Cable Alley I/C 400A,O/G 3P GF 8 Way, 4P 6 Way & A/F 6 Way	ISSBOU0682	ISSBOU0699
4	Cable Alley I/C 400A,O/G 3P GF 12 Way	ISSBOU0683	ISSBOU0700
5	Cable Alley I/C 400A,O/G 4P 8 Way & A/F 8 Way	ISSBOU0684	ISSBOU0701
6	CABLE ALLEY I/C 400A,O/G 4P 12WAY&A/F 12WAY	ISSBOU0685	ISSBOU0702

Note: For A frame 800A incomer Cable Alley codes please contact nearest branch.

* Each set of Cable Alley consists of two numbers, one each on LHS and RHS.



Pre-Wired Meter Module with Voltmeter, Ammeter, Selector Switch, Ct's Control Fuse & Indicating Lights

S. No.	Description	Single Door Cat. No.	Double Door Cat. No.
1	Prewire Meter Module - Analog	ISSBOU0689	ISSBOU0706
2	Meter Module - Digital	ISSBOU0711	ISSBOU0707

Bare Meter Module / MCB Module / Add on Module

S. No.	Description	Single Door Cat. No.	Double Door Cat. No.
1	Meter Module - Analog Provision for Ammeter, Voltmeter - Analog with selector switch	ISSBOU0686	ISSBOU0703
2	MCB Module	ISSBOU0687	ISSBOU0704
3	Add on Module	ISSBOU0688	ISSBOU0705

* Ammeter, Voltmeter, Selector Switch, Control Fuses, Indicating Lights, MCBs etc. have to be ordered separately and are at extra cost.

** The above prices are for bare module enclosures only.



Add on Incoming Changeover Switch Enclosure

S. No.	Description	Cat. No.
1	250A Incoming change Over switch-F1	ISSBOU0708
2	400A & 630A Incoming change Over switch - F2	ISSBOU0709
3	800A Incoming change Over switch - F3	ISSBOU0710

* Ammeter, Voltmeter, Selector Switch, Control Fuses, Indicating Lights, MCBs etc. have to be ordered separately and are at extra cost.

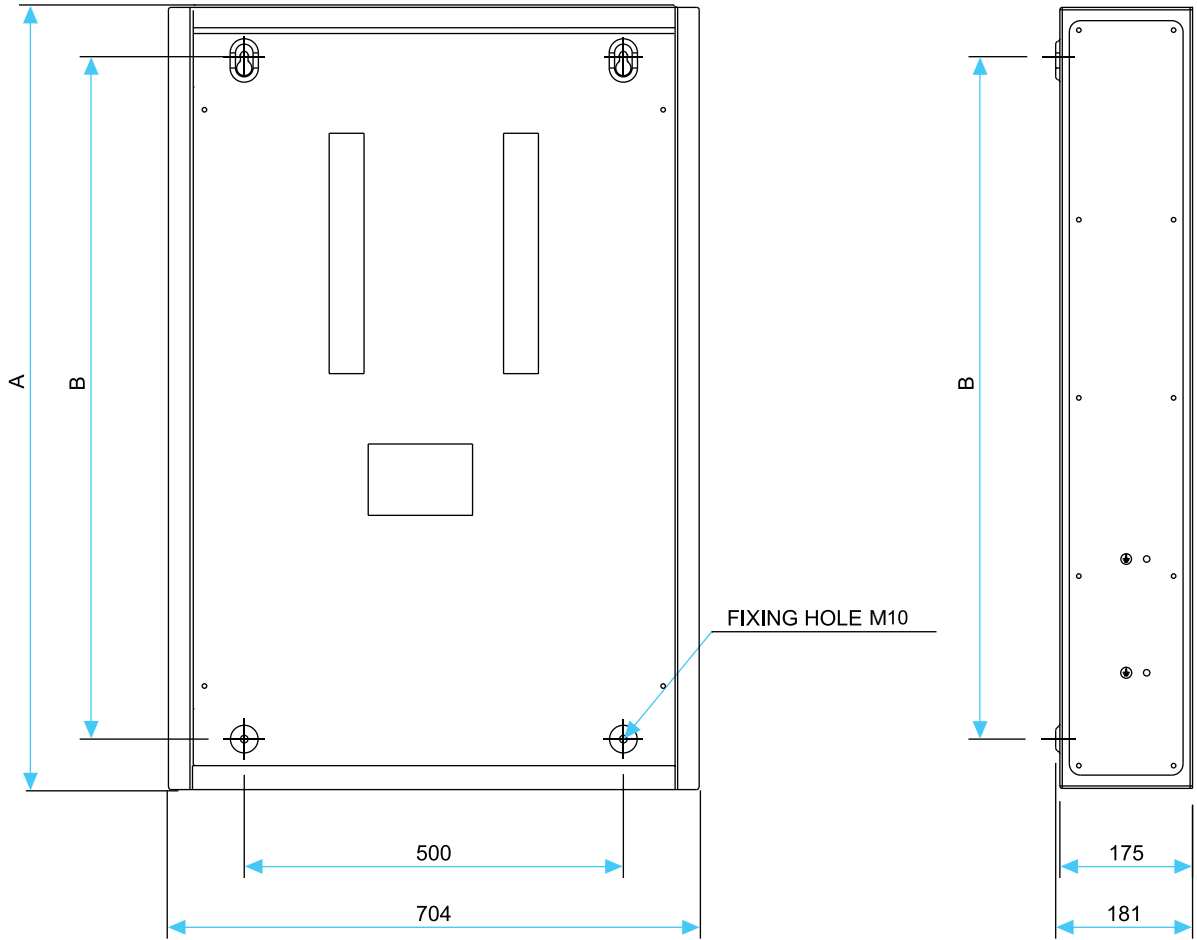

S. No.	Incomming	Outgoing	Type					
				Height (A)	CD (B)	Length	Single Door Width	Double Door Width
1	A-Frame Incomer 3P/4P (upto 250 A)	G-Frame 3P outgoing	2 WAY	879	742	704	181	202
			4 WAY	879	742	704	181	202
			6 WAY	932	795	704	181	202
			8 WAY	1037	900	704	181	202
			12 WAY	1194	1057	704	181	202
2	A-Frame Incomer 3P/4P (upto 250 A)	G-Frame 4P outgoing	2 WAY	932	795	704	181	202
			4 WAY	932	795	704	181	202
			6 WAY	1037	900	704	181	202
			8 WAY	1142	1005	704	181	202
			12 WAY	1352	1215	704	181	202
3	C-Frame 3P/4P Incomer (upto 400 A)	G-Frame 3P outgoing	2 WAY	979	842	704	181	202
			4 WAY	979	842	704	181	202
			6 WAY	1032	895	704	181	202
			8 WAY	1137	1000	704	181	202
			12 WAY	1294	1157	704	181	202
4	C-Frame 3P/4P Incomer (upto 400 A)	G-Frame 4P outgoing	2 WAY	1032	895	704	181	202
			4 WAY	1032	895	704	181	202
			6 WAY	1137	1000	704	181	202
			8 WAY	1242	1105	704	181	202
			12 WAY	1452	1315	704	181	202
5	C-Frame 3P/4P Incomer (upto 400 A)	A-Frame 3P outgoing	6 WAY	1137	1000	704	181	202
			8 WAY	1242	1105	704	181	202
			12 WAY	1452	1315	704	181	202
6	C-Frame 3P/4P Incomer (upto 630A and 800A)	A-Frame 3P outgoing	6 WAY	1137	1000	704	181	202
			8 WAY	1242	1105	704	181	202
			12 WAY	1452	1315	704	181	202

Dimensions in (mm)

Cable Alley

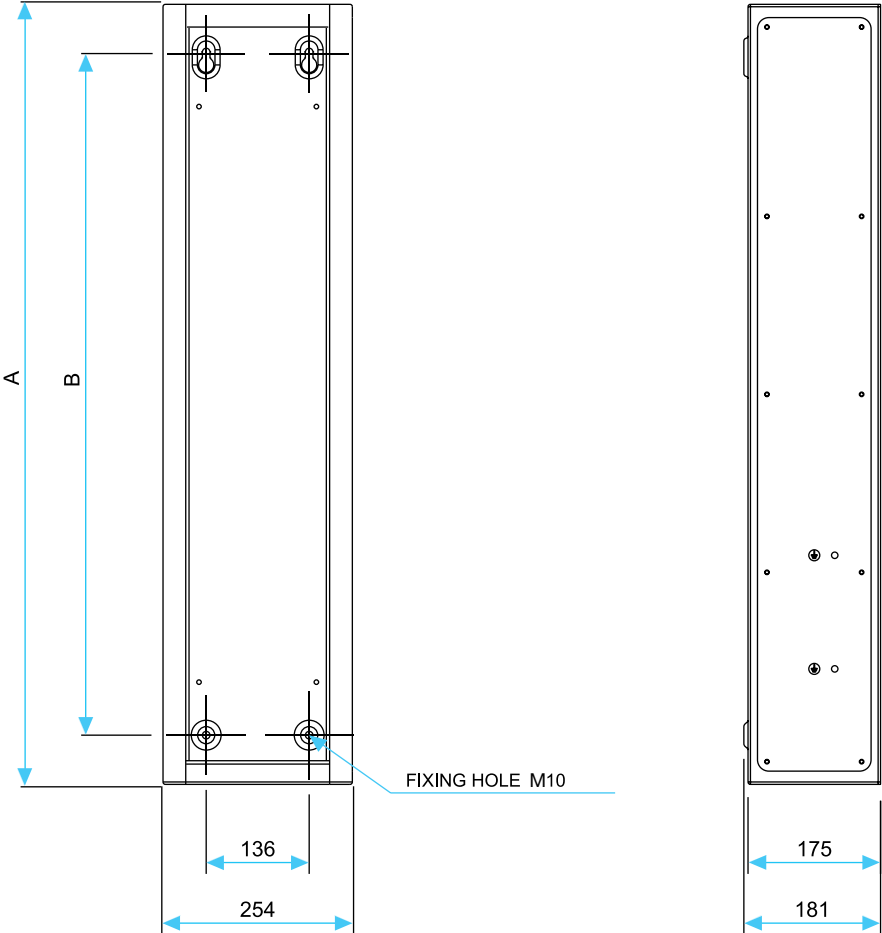

Meter Module

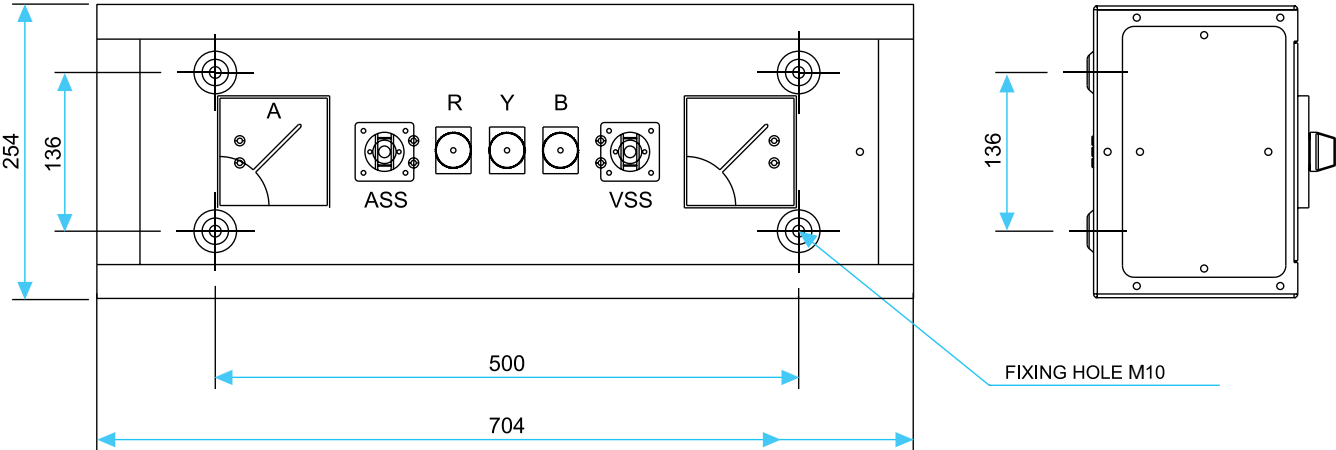

Euroload Changeover Switch

Features:

- Quick make & quick break mechanism.
- High electrical & mechanical endurance.
- Advance neutral.
- Enclosed housing to avoid dust ingress.
- Staggered terminals upto 800A.
- Load and Line reversibility.
- Provision of phase separators, add-on auxiliary switch
- Door interlock and padlock facility.
- Extended outgoing terminals.
- Available in open execution & in sheet steel enclosure.

Range :

- 40A to 3150A in 7 frame sizes in 4 Pole.

Specification :

IS / IEC 60947-1 & 3.

Euroload Changeover Switches find a wide application scope wherever the reliability of electrical supply from the utilities is low and are used in lighting/motor circuits wherever continuity of supply is necessary, for switching to an alternative source from main supply and vice versa. They are switch disconnectors with independent manual operation capable of making, carrying and breaking currents under normal circuit conditions which may include operating overload conditions and also carrying currents under specified abnormal circuit conditions such as those of short circuit for a specified time. These switches are modular in construction, compact in size and suitable for stringent utilization category AC-23A.



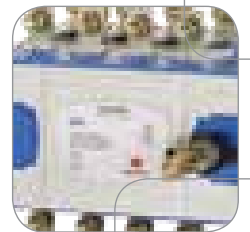
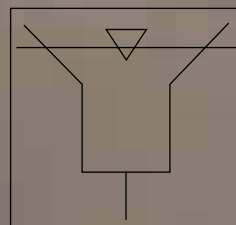
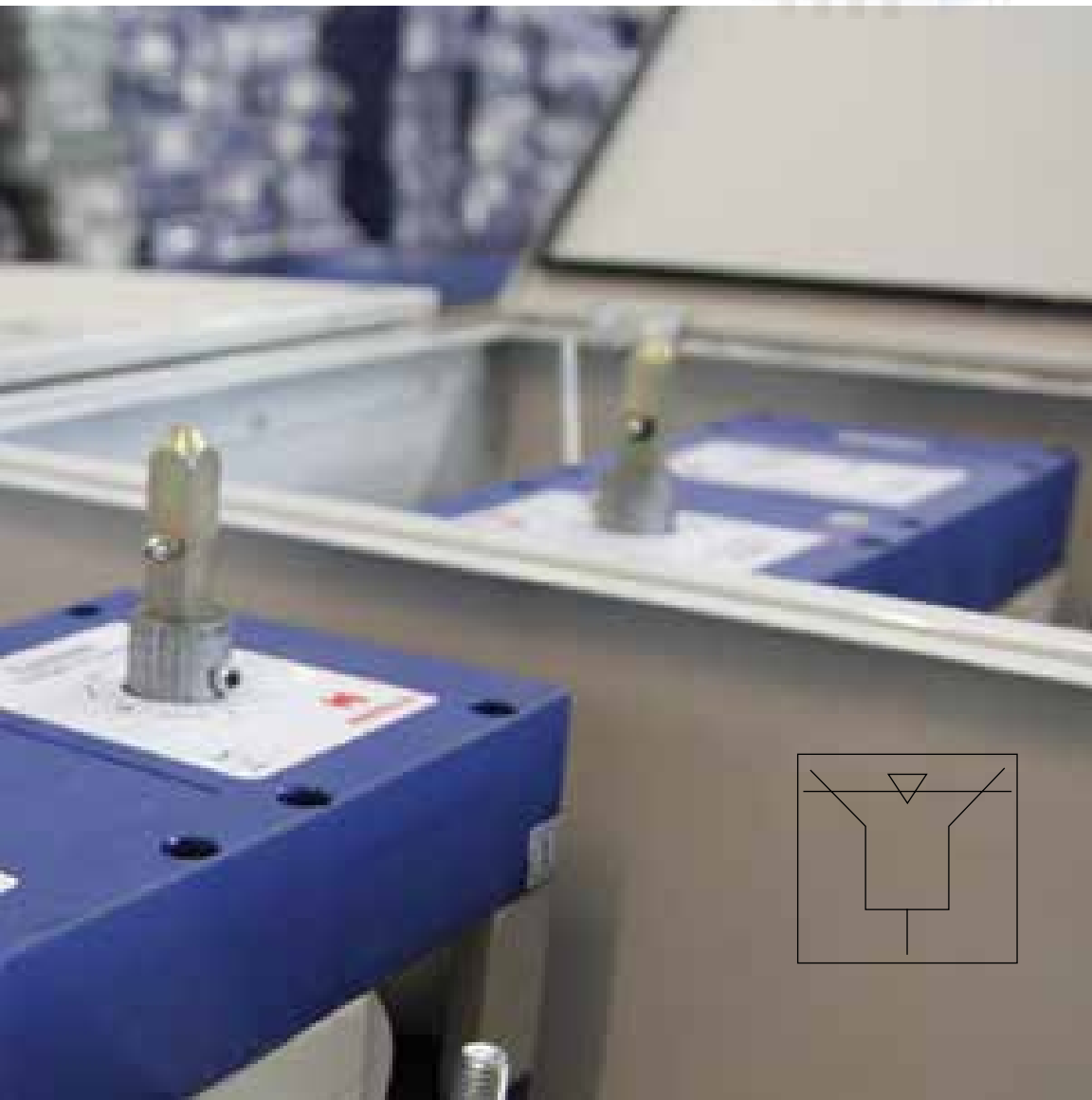



Euroload Changeover Switch has unique modular construction. The module comprises of two load switch disconnectors coupled together and mechanically interlocked with a common outgoing and operable by a single handle having I-O-II position.

The switching mechanism is quick make, quick break type independent of the speed of the operation. There are four breaks per pole thereby resulting into faster quenching of arc. The load and line can be connected on either side by virtue of isolation on both the sides. The entire switching mechanism alongwith the fixed and moving contact assembly are housed in a fiber glass reinforced Polyester, moulded frame/cover, having high dielectric strength & thermal withstand capacity.

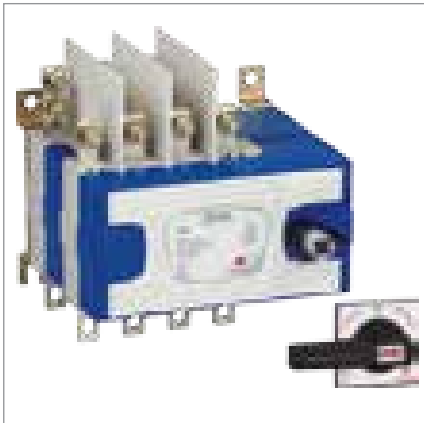

Contact Mechanism

The contact mechanism is knife blade type with self cleaning action during operation. The fixed contact terminals in each phase have separate main and arcing contacts. The moving contact assembly has four sets of contacts on moving carrier and the entire assembly rests on three guides on moving carrier itself, which assists in its true movement during making and breaking.

The moving contact mates with the fixed contact by slide movement of the moving contact assembly. The contact is first made with the arcing contact and thereafter with the main contact. During breaking, the arc formation is across the arcing contacts thereby protecting the main contacts which results into enhanced life of the switch. The arc is effectively quenched & confined in arc barrier in each phase.

The switches can be mounted inside a panel either in horizontal or vertical mode without any effect on the performance.

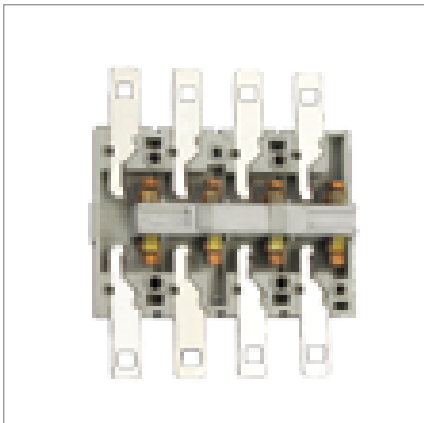

Operating Mechanism

The operating mechanism consists of single side from operated handle which drives the spring assisted toggle mechanism, inturn operating the switch. Position indication provided on front of switch, i.e. on the operating shaft.

In position 'I', supply I (Main) is connected to the load, supply II is off.

In position 'O', supply I & II are both disconnected from the load.

In position 'II', supply II (Standby) is connected to the load, supply I is off.

Hence in none of the cases, supply I & II are connected simultaneously.



Technical Information

Frame Size 00

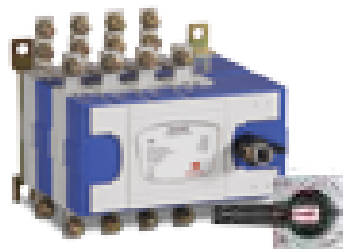

Frame Size		Size 00				
Current Rating	I_e	A	40	63	80	100
Nos. of Poles			4	4	4	4
Rated Operational Voltage ac	U_e	V	415	415	415	415
Rated Insulation Voltage	U_i	V	1000	1000	1000	1000
Rated Impulse Voltage	$U_{imp.}$	kV	8	8	8	8
Rated Frequency		Hz	50	50	50	50
Design temp./ Ambient Temp. Deg. C			40	40	40	40
Utilization Category			AC23A			
Conventional Enclosed Thermal Current at 40° C	I_{the}	A	40	63	80	100
Rated Operational Power at 415V, 3ø		KW	23	36	46	58
Making Capacity AC23A		A	400	630	800	1000
Breaking Capacity AC23A		A	320	504	640	800
Conditional Short ckt current		KA_{rms}	80	80	80	80
With Havells Fuse Ratings gG		A	40	63	80	100
Electrical Endurance		opers.	1500	1500	1500	1500
Mechanical Endurance		opers.	10000	10000	10000	10000
Temperature withstand range (Ambient)		°C	-5 to 50	-5 to 50	-5 to 50	-5 to 50
Min. Cu cable section		Sq.mm	10	16	25	35
Min. Al. cable section		Sq.mm	16	25	35	50
Terminal Bolt Size Metric thread diameter x length			M6 X 16			
Overall Dimensions H X W X D		mm	136.5 X 144 X 158			
Weight	Open Execution	kg.	1.5	1.5	1.6	1.6
	In Enclosure	kg.	4.5	4.5	4.6	4.6

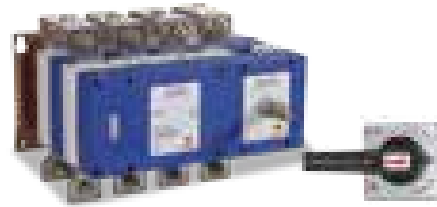

Frame Size		Size 0		
Current Rating	A	125	160	200
No. of Poles		4	4	4
Rated insulation voltage, U_i	V	1000	1000	1000
Rated operational voltage, U_e	V	415V	415V	415V
Dielectric strength, 50 Hz	KV	5	5	5
Rated impulse withstand voltage, U_{imp}	KV	8	8	8
Conventional Enclosed Thermal Current at 40° C, I_{the}	A	125	160	200
Rated operational current, I_e				
at 415V	AC 23A	125	160	200
at 500V	AC 23A	100	140	140
Rated making capacity Amp, 436V AC23A, p.f.- 0.35		1250	1600	2000
Rated breaking capacity Amp, 436V AC23A, p.f.- 0.35		1000	1280	1600
Rated operational power at 415V, 3ϕ	kW	72	92	115
Rated conditional short circuit current, KA_{rms}		80	80	80
Max. Allowed cut off current, KA_{peak}		17	18	22
Electrical Durability				
No. of operating cycles AC-23A		1000	1000	1000
Mechanical Durability				
No. of no load operating cycles		8000	8000	8000
Temperature withstand range (Ambient)	°C	-5 to 50	-5 to 50	-5 to 50
Terminal connection				
Al. Cable/Bus Bar cross section	mm ²	70	95	150
Cu. Cable/Bus Bar cross section	mm ²	50	70	95
Weight				
Open Execution	Kg.	3.60	4.00	4.00
In Enclosure, Kg.		8.60	9.00	9.2

Frame Size		Size 1		Size 2	
Current Rating	A	250	320	400	630
No. of Poles		4	4	4	4
Rated insulation voltage, U_i	V	1000	1000	1000	1000
Rated operational voltage, U_e	V	415V	415V	415V	415V
Dielectric strength, 50 Hz	KV	5	5	8	8
Rated impulse withstand voltage, U_{imp}	KV	8	8	8	8
Conventional Enclosed Thermal Current at 40° C, I_{the}	A	250	320	400	630
Rated operational current, I_e					
at 415V	AC 23A	250	320	400	630
at 500V	AC 23A	200	250	400	400
Rated making capacity Amp, 436V AC23A, p.f.- 0.35		2500	3200	4000	6300
Rated breaking capacity Amp, 436V AC23A, p.f.- 0.35		2000	2550	3200	5100
Rated operational power at 415V, 3ϕ	kW	144	184	230	362
Rated conditional short circuit current	KA_{rms}	80	80	80	80
Max. Allowed cut off current	KA_{peak}	27	33	39	55
Electrical Durability					
No. of operating cycles AC-23A		1000	1000	1000	1000
Mechanical Durability					
No. of no load operating cycles		8000	5000	5000	5000
Temperature withstand range (Ambient)	°C	-5 to 50	-5 to 50	-5 to 50	-5 to 50
Terminal connection					
Al. Cable/Bus Bar cross section	mm ²	185	240	300	40 x 8 x 2
Cu. Cable/Bus Bar cross section	mm ²	120	185	240	40 x 5 x 2
Weight					
Open Execution	Kg.	7.50	8.00	15.50	16.50
In Enclosure	Kg.	17.00	17.50	31.20	32.20

For ratings 630A & above Bus Bar Termination Recommended

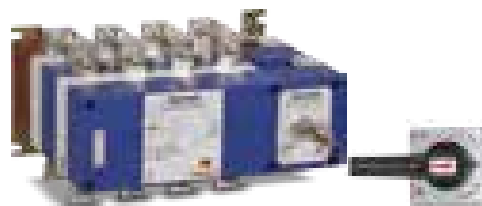

Frame Size		Size 3		Size 4	
Current Rating	A	800	1000	1250	1600
No. of Poles		4	4	4	4
Rated insulation voltage, U_i	V	1000	1000	1000	1000
Rated operational voltage, U_e	V	415V	415V	415V	415V
Dielectric strength, 50 Hz, V	KV	10	10	10	10
Rated impulse withstand voltage, U_{imp}	KV	8	8	8	8
Conventional Enclosed Thermal Current at 40° C, I_{the}	A	800	1000	1250	1600
Rated operational current, I_e					
at 415V	AC 23A	800	1000	1250	1600
at 500V	AC 23A	500	800	800	1000
Rated making capacity Amp,436V AC23A, p.f.- 0.35		8000	10000	12500	16000
Rated breaking capacity Amp,436V AC23A, p.f.- 0.35		6400	8000	10000	12800
Rated operational power at 415V, 3ϕ	kW	460	575	719	920
Rated conditional short circuit current	KA_{rms}	80	80	80	-
Max. Allowed cut off current	KA_{peak}	70	86	100	-
Electrical Durability					
No. of operating cycles AC-23A		500	500	500	500
Mechanical Durability					
No. of no load operating cycles		3000	3000	3000	3000
Temperature withstand range (Ambient)	°C	-5 to 50	-5 to 50	-5 to 50	-5 to 50
Terminal connection					
Al. Cable/Bus Bar cross section mm^2		50 x 8 x 2	50 x 10 x 2	63 x 12 x 2	50 x 8 x 4
Cu. Cable/Bus Bar cross section mm^2		50 x 5 x 2	60 x 5 x 2	80 x 5 x 2	100 x 5 x 2
Weight					
Open Execution	Kg.	27.00	46.00	48.00	51.00
In Enclosure	Kg.	44.50	82.00	84.00	87.00

Frame Size		Size 5		
Current Rating	A	2000	2500	3150
No. of Poles		4	4	4
Rated insulation voltage, U_i	V	1000	1000	1000
Rated operational voltage, U_e	V	415V	415V	415V
Dielectric strength, 50 Hz	KV	10	10	10
Rated impulse withstand voltage, U_{imp}	KV	8	8	8
Conventional Enclosed Thermal Current at 40° C, I_{the}	A	2000	2500	3150
Rated operational current, I_e				
at 415V	AC 23A	2000	2500	3150
at 500V	AC 23A	1000	1000	1000
Rated making capacity Amp,436V AC23A, p.f.- 0.35		20000	25000	31500
Rated breaking capacity Amp,436V AC23A, p.f.- 0.35		16000	20000	25200
Rated operational power at 415V, 3ϕ	kW	1150	1438	1811
Rated conditional short circuit current	KA_{rms}	80	80	80
Electrical Durability				
No. of operating cycles AC-23A		500	500	500
Mechanical Durability				
No. of no load operating cycles		3000	3000	2000
Temperature withstand range (Ambient)	°C	-5 to 50	-5 to 50	-5 to 50
Terminal connection				
Al. Cable/Bus Bar cross section mm^2		100 x 10 x 3	100 x 10 x 4	150 x 10 x 4
Cu. Cable/Bus Bar cross section mm^2		100 x 5 x 3	100 x 5 x 4	100 x 10 x 3
Weight				
Open Execution	Kg.	88.00	91.50	98.00

* For ratings 630A & above Bus Bar Termination Recommended

Frame-00

Current Rating (A)	Open Execution Cat. No.	In Enclosure Cat. No.
040	IHCNFO0040	IHCNFE0040
063	IHCNFO0063	IHCNFE0063
080	IHCNFO0080	IHCNFE0080
100	IHCNFO0100	IHCNFE0100

Frame-0

Current Rating (A)	Open Execution Cat. No.	In Enclosure Cat. No.
125	IHCNFO0125	IHCNFE0125
160	IHCNFO0160	IHCNFE0160
200	IHCNFO0200	IHCNFE0200

Frame-1

Current Rating (A)	Open Execution Cat. No.	In Enclosure Cat. No.
250	IHCNFO0250	IHCNFE0250
320	IHCNFO0320	IHCNFE0320

Frame-2

Current Rating (A)	Open Execution Cat. No.	In Enclosure Cat. No.
400	IHCNFO0400	IHCNFE0400
630	IHCNFO0630	IHCNFE0630

Frame-3

Current Rating (A)	Open Execution Cat. No.	In Enclosure Cat. No.
800	IHCNFO0800	IHCNFE0800

Frame-4

Current Rating (A)	Open Execution Cat. No.	In Enclosure Cat. No.
1000	IHCNFO1000	IHCNFE1000
1250	IHCNFO1250	IHCNFE1250
1600	IHCNFO1600	IHCNFE1600

Frame-5

Current Rating (A)	Open Execution Cat. No.	In Enclosure Cat. No.
2000	IHCNFO2000	IHCNFE2000
2500	IHCNFO2500	IHCNFE2500
3150	IHCNFO3150	IHCNFE3150



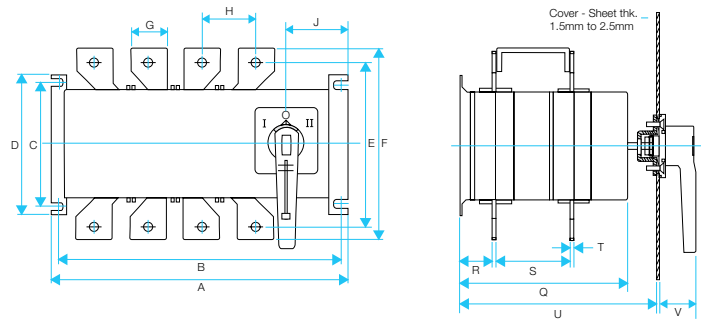

Dimensions (in mm) - Open Execution

Current (A)	A	B	C	D	E	F	G	H	J	Q	R	S	T	U	V
40A-100A	144	128	95	111	96.5/106.5	126	12	26	21	125	26	51	2.5	156	44
125A-200A	220	207	113	132	122	148	20/24	46	34	174	54	69	3.2	215	62
250A-320A	315	306	134	156	147/165	177/198	28/35	58/63	54	220	57	89	4	260	62
400A-630A	405	378	184	206	221/241	251/281	40/55	80	76	270	67	110	5	308	62
800A	464	430	212	234	280	330	45	97	76	292	71	120	8	342	62
1000A-1600A	575	530	290	315	331	380	70	100	79	362	100	143	13	416	62

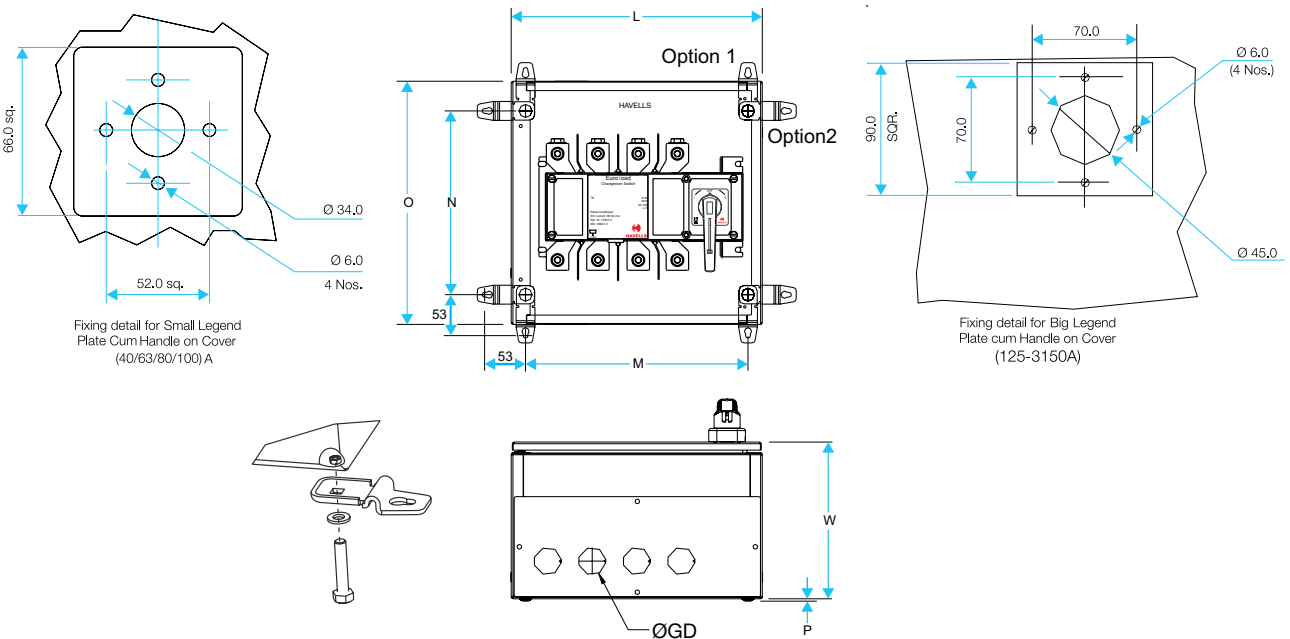

Dimension (in mm) - Enclosure

Ratings	L	M	N	O	P	W	ØGD
40A-100A	210	160	200	256	5	165	22
125A-200A	310	260	260	320	5	217	34
250A-320A	445	397	352	400	5	262	42
400A-630A	524	476	482	530	5	310	80
800A	563	515	552	600	5	345	105
1000A-1600A	740	705	530	630	6	420	-

Dimensions (in mm) - with Enclosure for 2000A, 2500A & 3150A

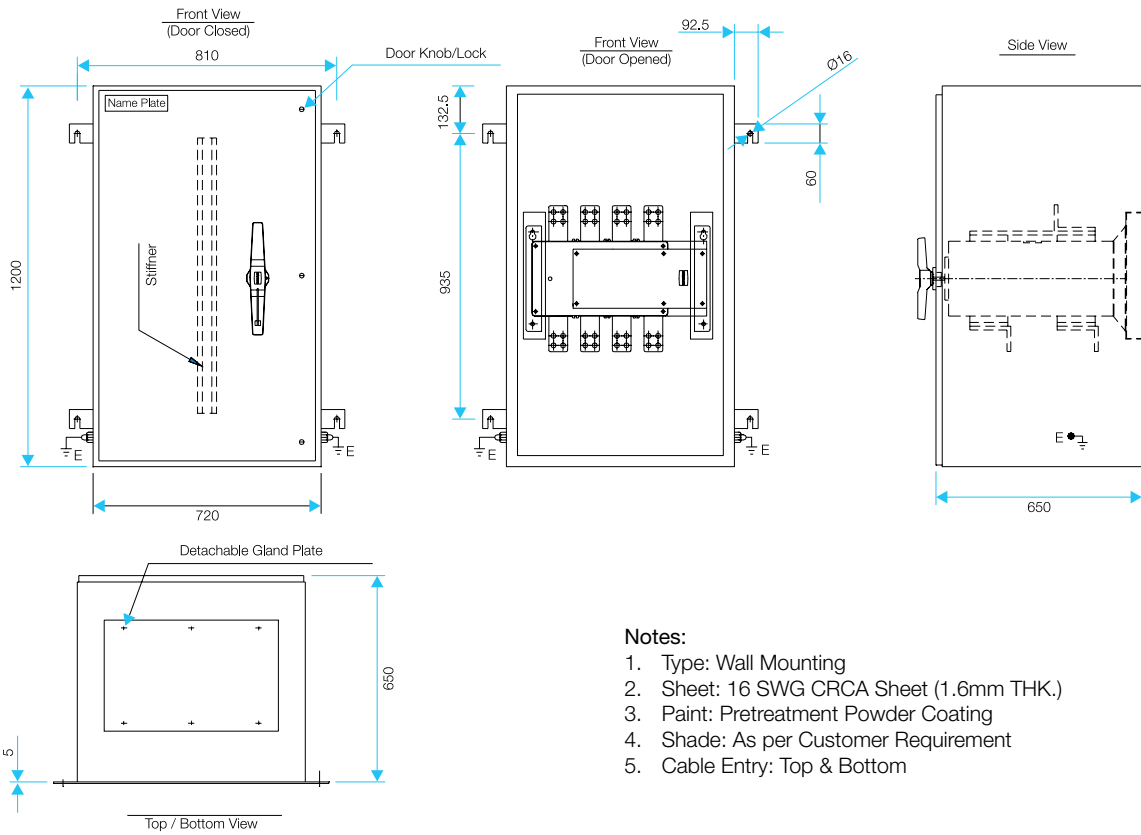

Notes:

1. Type: Wall Mounting
2. Sheet: 16 SWG CRCA Sheet (1.6mm THK.)
3. Paint: Pretreatment Powder Coating
4. Shade: As per Customer Requirement
5. Cable Entry: Top & Bottom

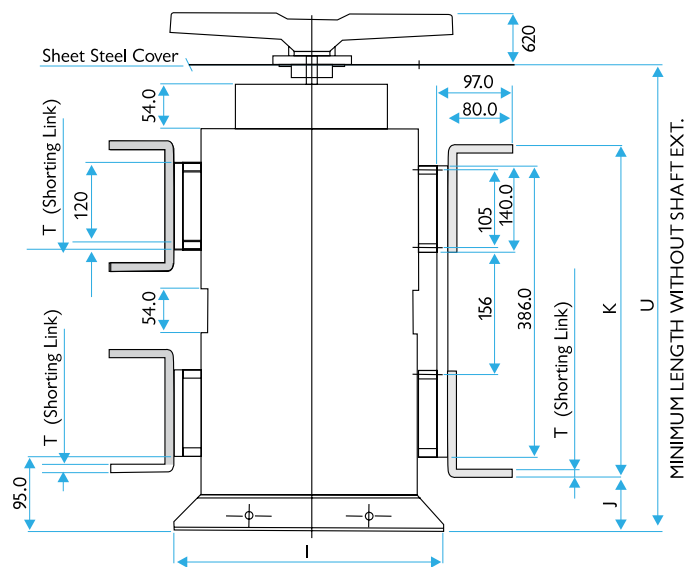

Dimensions (in mm) - Open Execution

Current (A)	A	B	C	D	E	F	G	H	J	Q	R	S	T	U	V
2000A-3150A	575	530	290	315	420	470	75	100	68.5	570	66/68.5	120	12/15	620	62



Accessories	
Auxiliary Contact	Cat. No.
1 No. 1 NC	IHCNFAC1CO
2 No. 2 NC.	IHCNFAC2CO

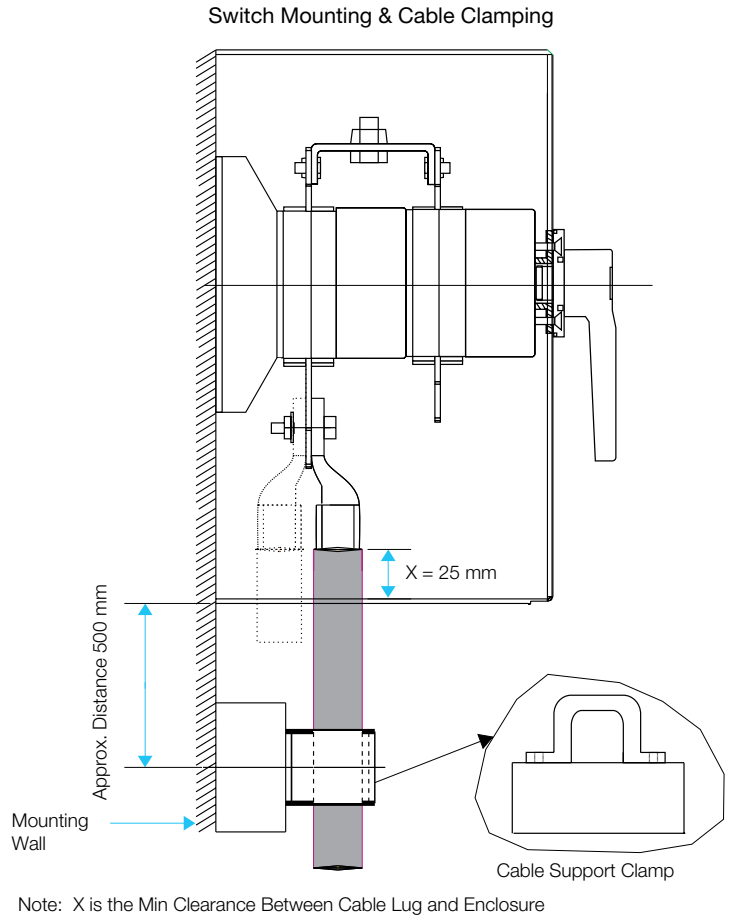
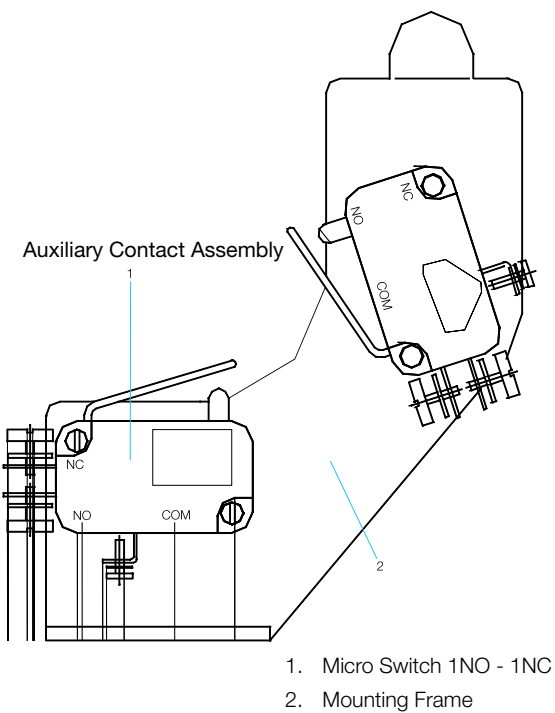

Aluminium / Copper Cable / Bus Bar Size for External Termination							
I _n	φT	S max. Nm	S max. (Al)mm ²	L (Cu)mm	H (Cu)mm	Switch mounting (Cu)mm	Fastener Size
125 A	M8	9	70	50	3.2	20	
160 A	M8	9	95	70	3.2	24	
200 A	M8	9	150	95	3.2	24	M6 x 15
250 A	M8	9	185	120	4	28	
320 A	M10	48	240	185	4	35	
400 A	M10	48	300	240	5	40	
630 A	M10	48	2x40x8	2x40x5	5	55	M8 x 15
800 A	M12	48	2x50x8	2x50x5	8	45	
1000 A	M12	84	2x50x10	2x60x5	10	70	
1250 A	M12	84	2x63x12	2x80x5	12	70	M10 x 15
1600 A	M12	84	4x50x8	2x100x5	15	70	

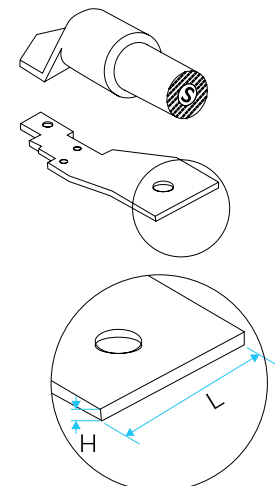

Switch mountings and fitments have been detailed in installation sheets which are supplied with every switch.

Euroload By-pass Changeover Switch

Features:

- Robust and reliable mechanism provides total disconnection.
- Quick make and break operation, independent of the operating speed enables the switches to open and close under stringent conditions, namely AC23A utilizations.
- The switch housing is made of fiber glass reinforced polyester, which has excellent mechanical, di-electric and thermal properties.

Range :

In current ratings of 63A-1600A in 6 frame sizes in 4 Pole execution.

Specification :

IS / IEC: 60947-1&3

Havells On-Load By-Pass Switch connects normal supply to the loads in case stabilized source fails. In fact, it By-passes the UPS/Servo Stabilizer in case of their failure and provides a means of connecting alternate supply to the load. The switch also ensures isolation of the up-stream and down-stream circuit.



Euroload

By-Pass Changeover Switch





Application

The By-pass switches are designed to meet customer specific needs particularly in IT related industries where UPS and Servo stabilizers provide main source of supply. In the event of an emergency, normal supply can be made available to the services without interrupting any installation and at the same time providing time for maintenance of UPS systems without causing break down of services.

Operation

The By-pass Switch is operated manually with handle. It provides 3 stable positions namely :

- 0 Loads are open circuited
- I Loads are connected to stabilized supply
- II Loads are connected to the normal supply

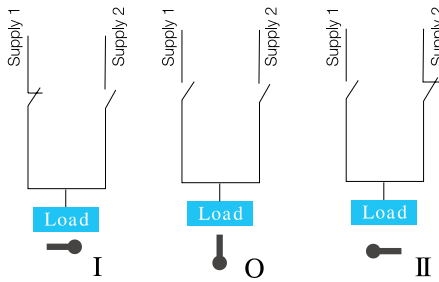

Single Line Diagram

At '0' position, all the contacts of the three disconnectors are open and thereby provide isolation. At 'I' position, disconnectors No. I and III are closed and disconnector II is open. Hence stabilized supply is connected to the load. At 'II' position only disconnector No. II is closed and I & III are open. Hence bypassing the UPS and connecting the load directly to normal supply.

Auxiliary contact :

Auxiliary contacts having 1 NO. NC or 2 NO. NC configuration can be provided for indication and signaling purposes.



Ordering Information

Frame Size	Current Rating (A)	Open Execution Cat. No.
00	63	IHCBFO0063
00	100	IHCBFO0100
0	125	IHCBFO0125
0	160	IHCBFO0160

Frame Size	Current Rating (A)	Open Execution Cat. No.
0	200	IHCBFO0200
1	250	IHCBFO0250
1	320	IHCBFO0320
2	400	IHCBFO0400

Frame Size	Current Rating (A)	Open Execution Cat. No.
2	630	IHCBFO0630
3	800	IHCBFO0800
4	1000	IHCBFO1000
4	1250	IHCBFO1250
4	1600	IHCBFO1600

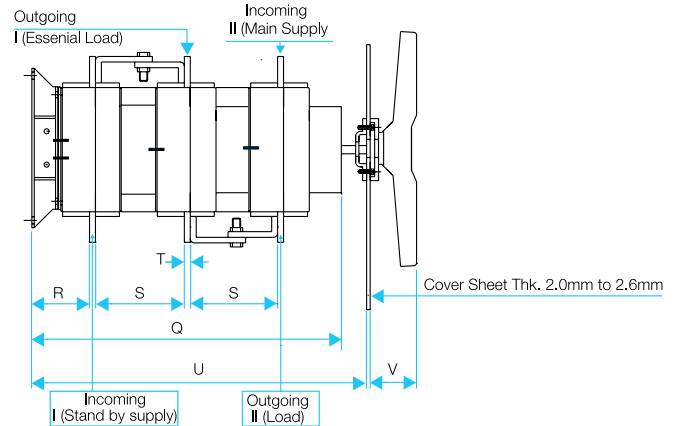
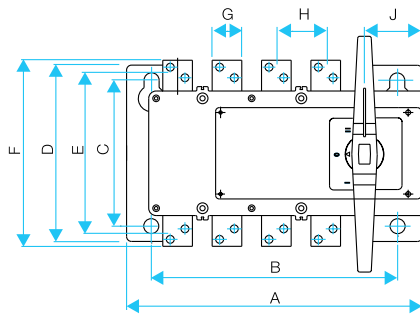

Current (A)	A	B	C	D	E	F	G	H	J	Q	R	S	T	U	V
Size 63A	144	128	95	111	120	136	12	25	29	178	26	51	2.5	210	44
Size 100A	144	128	95	111	135	150	12	25	29	178	26	51	2.5	210	44
125	220	207	113	132	122	148	20	46	34	250	54	69	3.2	272	62
160	220	207	113	132	122	148	24	46	34	250	54	69	3.2	272	62
200	220	207	113	132	122	148	24	46	34	250	54	69	3.2	272	62
250	315	300	134	156	165	198	28	58	54	331	57	89	4.0	337	62
320	315	300	134	156	165	198	35	63	54	331	57	89	4.0	337	62
400	405	378	184	206	221	251	40	80	76	385	67	110	5.0	405	62
630	405	378	184	206	241	281	55	80	76	385	67	110	5.0	405	62
800	464	430	212	234	280	330	45	80	76	420	71	120	8.0	440	62
1000	575	530	290	315	331	380	70	100	85	514	101	145	10.0	534	62
1250	575	530	290	315	331	380	70	100	85	514	100	143	12.0	534	62
1600	575	530	290	315	331	380	70	100	85	514	98.5	140	15.0	534	62

Technical Information

Frame Size		Size 00		Size 0			Size 1		Size 2		Size 3		Size 4		
Rated Current I_{th}	A	63	100	125	160	200	250	320	400	630	800	1000	1250	1600	
Rated Insulation Voltage U_i	V	1000													
Rate Operational Voltage U_e	V	415													
Di-Electric Strength 50 Hz	kV	5	5	5	5	5	5	5	8	8	10	10	10	10	
Rated impulse withstand voltage (U_{imp})	kV	8													
Rated Short Circuit Current with fuse	kA RMS	80													
Making Capacity 436V, AC 23A PF=0.45 (63A) / = 0.35 ($I_e \geq 100A$)	A	630	1000	1250	1600	2000	2500	3200	4000	6300	8000	10000	12500	16000	
Braking Capacity 436V, AC 23A PF=0.45 (63A) / = 0.35 ($I_e \geq 100A$)	A	504	800	1000	1280	1600	2000	2550	3200	5100	6400	8000	10000	12800	
Mechanical Durability		10000		8000			8000		5000		3000		3000		
Electrical Durability		1500		1000			1000		1000		500		500		
Terminal Connection															
Aluminium Cable/Busbar Cross-section	mm ²	25	50	70	95	150	185	240	300	40x8x2	50x8x2	50x10x2	63x12x2	50x8x4	
Copper Cable / Busbar Cross-section	mm ²	16	35	50	70	95	120	185	240	40x5x2	50x5x2	60x5x2	80x5x2	100x5x2	

Automatic Transfer Switch

Features:

- High speed transfer
- Superior making & breaking capacity
- Compact & light weight design
- Positive indication through flag indicator
- Neutral point transfer
- Liberal terminals
- Phase barriers Range

Range :

Current rating from 100A to 630A in three frame sizes in three pole and four pole execution.

Specification :

Conforms to IS/IEC:60947-6-1

The need for continuous power supply and its reliability has increased rapidly over the years, especially in all those areas where uninterrupted power supply is a must. Modern systems are power dependent. Their complexity has increased as continuous information and communications are needed to control automated process, be in industries, commercial complexes, hospitals, hotels or even modern residences.

The need, as such, for independent stand by power system has therefore increased manifold. The power distribution, control, monitoring and protection of stand by power system needs to be integrated. Stand by generator systems, for example, are required to cater to :-

- **Sensitive Loads** are supplied by UPS systems. The period of non-availability of power, before the stand by supply takes over, is bridged by battery banks. Typical loads are computers, hospital equipments, micro processor controlled industrial machines etc.
- **Critical Loads** mostly involve stand by generator systems which supply power to lighting systems, air conditioning, elevators etc in Airports, Hotels and commercial complexes.
- **Essential Loads** also use stand by generator systems mostly in process industries as they relate to high restarting times or high down times.

Automatic transfer from main supply to stand by supply is vital for all the above kinds of loads.

In the event of power failure, the stand by power is usually expected to take over automatically. Electrical starting equipment, battery bank and diesel generator are required for the automatic operation.

The automatic transfer is achieved mostly by automatic mains failure systems. The process of onload transfer has to be monitored & controlled for a smooth Changeover and within safety limits of all elements of the system. This is achieved by Automatic Transfer Switch (ATS). Range

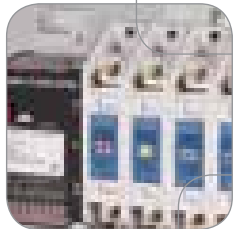
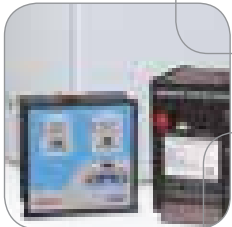
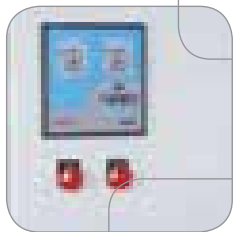

The Switch comprises of upto four symmetrical poles coupled with the Main Operating Mechanism. The switching mechanism is quick make, quick break type. Load terminals are given on the Lower side but can also be provided on the upper side.

Contact Mechanism

The contact system is housed in a frame made of Polyester reinforced glass material. Each pole has two independent set of Moving contact assemblies for Main & standby supply and one Fixed contact assembly for the common outgoing load terminals. The Moving assemblies are mechanically operated by Cams when rotated by the Main Operating Mechanism. Moving Contacts make on to Fixed Contacts under constant pressure with backup spring. Main Contacts are made of Silver-Tungsten to ensure anti-weld characteristics. The Arc Chute plates placed in the path of contact, efficiently quench the Arc and there by enhance the life of the contacts.

Main Operating Mechanism

The main mechanism independently actuates two sets of Cam linkages, which in turn operate the two independent moving contact assemblies.

The closing command is through a Solenoid Coil supplied with 220V AC. The operating mechanism always responds by closing on the main supply side and not on to standby supply side, when both supplies are present.

The tripping coil, when energised, is used to bring the ATS to OFF / Neutral position. Closing on to the standby supply is achieved through the selective coil. The energisation of selective coil, disengages the main mechanism and prevents closing on to the main supply. The solenoid coil can then close the second set of moving contacts on to the standby supply. The moving contact mechanism of the main supply and the standby supply are inherently mechanically interlocked through a double throw arrangement, which ensures that at no point of time two supplies are paralleled.

Cross Sectional View of Single Pole of ATS

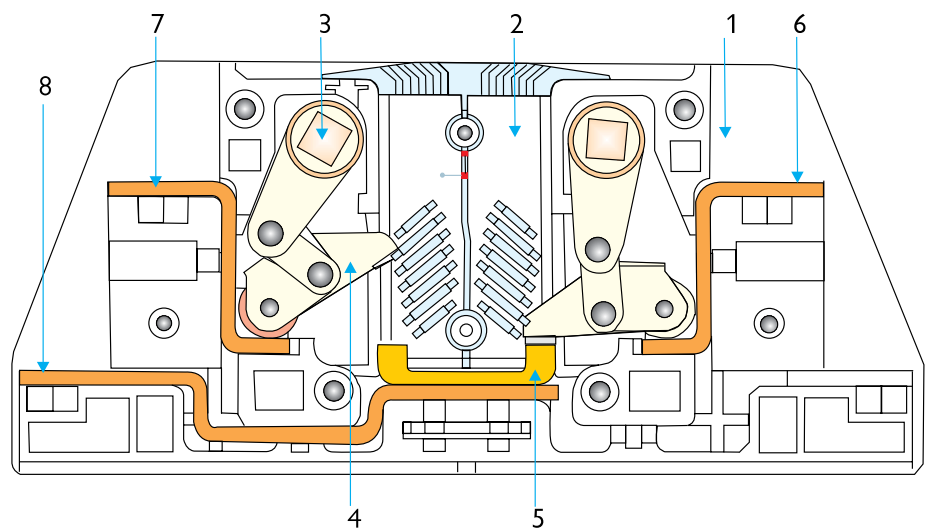

- | | |
|--------------------------------|---------------------------------------|
| 1 Frame | 5 Fixed Contact |
| 2 Housing for Arc Chute | 6 Main Supply - Incoming Terminals |
| 3 Operating Shaft for Contacts | 7 Standby Supply - Incoming Terminals |
| 4 Moving Contact | 8 Common outgoing - Load Terminals |

1. Manual Operating Handle
2. Earthing Terminal
3. Name Plate
4. Trip Button
5. Selector (Source-II)
6. On / Off Indicators (Source I & II)
7. Main Supply Terminals
8. Arc Extinguishing Chambers
9. Auxilliary Switch (2 nos.)
10. Standby Supply Terminals
11. Control Circuit Terminal Block
12. Terminals For Load
13. Actuator For Closing Coil
14. ATS Controller Unit
15. Control Wiring
16. ATS Protection Unit (optional)
17. Online Float Charger cum UPS



Operation

(Automatic)

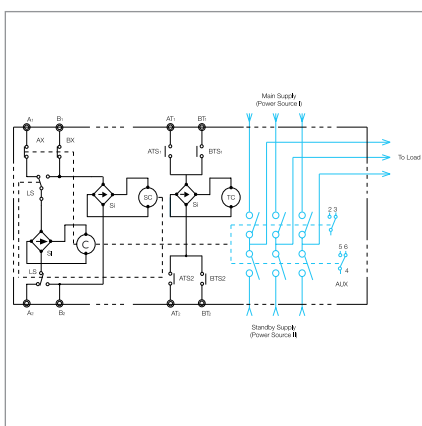

In the event of main supply being available, the ATS can be instantaneously switched ON, by the closing coil C, through terminals A1, A2, from its OFF / Neutral position.

If the ATS is ON at the standby supply position, then it is first tripped by the trip coil TC, through terminals BT1 - BT2. This ensures that the two sources of supply are not paralleled. A suitable external control circuit will ensure this, as shown in circuit diagram for Automatic Instantaneous Changeover mode.

The Auxiliary Switches AX or BX, disconnect the closing coil C, once the ATS is ON, thereby the power consumption of the coil C is zero, when the ATS is closed.

To switch the ATS to standby supply, the selective coil SC is first energised. Then the closing coil C is powered through limit switches LS and terminals B1, B2.

The Trip Coil TC, can be energised through AT₁ - AT₂ or BT₁ - BT₂ to switch off the main supply or standby supply.

Operation

(II Emergency)



In an emergency, the ATS can be operated manually, but as an off-load switch only.

Close on to Main Supply

A manual handle rotates the operating shaft by about 45° in anticlockwise direction, to achieve closure, under off-load conditions.

Close on to Standby Supply

Closure on to standby supply side is achieved, when the “selective” mode is continuously pressed and the manual handle rotates the operating shaft by about 45° in anticlockwise direction.

Trip

Tripping can be achieved manually by pressing momentarily through the “Trip Button”.



Closing ATS manually to source-II

1. Keep selector pressed using a screwdriver through the selector hole as shown
2. Switch to source-II (mains) by rotating the handle upwards through an angle (approximately 45°)

Closing ATS manually to source-I

Switch to source-I (mains) by rotating the handle upwards through an angle (approximately 45°)

Technical Information



Frame Size		TNFO1	TNFO2	TNFO3	TNFO3	TNFO3	TNFO3
Rated Operational Current I _e	A	100	160	200	315	400	630
No. of Poles		3P / 4P	3P / 4P	3P / 4P	3P/4P	3P / 4P	3P / 4P
Rated Insulation Voltage U _i	V	1000	1000	1000	1000	1000	1000
Rated Operational Voltage U _e	V	415V AC/110V DC		415V AC / 110V DC		415V AC / 110V DC	
Rated frequency	Hz	50	50	50	50	50	50
Class		PC	PC	PC	PC	PC	PC
Utilization Category		AC 31A	AC 31A	AC 31A	AC31A	AC 31A	AC31A
Dielectric Strength	KV	5	5	5	5	5	5
Rated Impulse withstand Voltage U _{imp}	KV	8	8	8	8	8	8
Rated making capacity at 415V (Cosφ = 0.80)	A	150	240	300	473	600	945
Rated breaking capacity at 415V (Cosφ = 0.80)	A	150	240	300	473	600	945
Rated short time withstand current (1 sec)	KA _{rms}	5	7	10	12	12	15
Fuse protected S/C withstand current	KA _{rms}	80	80	80	80	80	80
Rated Short circuit making capacity	KA _{rms}	7.65	17	17	17	17	25.2
Mech. Life (No. of ops.)		10,000	10,000	10,000	10,000	10,000	10,000
Elect. Life (No. of ops.)		6,000	6,000	6,000	6,000	4,000	2,000
Switching frequency (ops. per Hr)		60	60	60	60	60	60
Terminal Position		Front	Front	Front	Front	Front	Front
Terminal Capacity - Cu (cable)	mm ²	35	70	95	185	240	---
Al (cable)	mm ²	50	95	150	240	300	---
Busbar	mm	---	---	---	---	40 x 5 x 2	40 x 8 x 2
Weight 3P Kg		8.3	8.7	10.5	11.0	18.0	19.5
4P Kg		9.3	9.7	11.5	12.0	21.0	22.5
Mounting		Vertical	Vertical	Vertical	Vertical	Vertical	Vertical
Coil							
Operating Voltage	V	200 / 220	200 / 220	200 / 220	200 / 220	200 / 220	200 / 220
Operating Current	A						
Main Coil 3P / 4P		3.0/3.5	3.0/3.5	4.0/4.5	4.0/4.5	8.0/10.5	8.0/10.5
Trip Coil		0.5	0.5	0.5	0.5	0.7	0.7
Operating Time	(ms)						
Main Power Source Make		55	55	55	55	60	60
Break		20	20	20	20	25	25
Standby Power Source Make		80	80	80	80	90	90
Break		20	20	20	20	25	25
Changeover time		(Using Controller Mode)					
Changeover time min		-	-	0.1 sec	-	-	-
Changeover time max		-	-	60 sec	-	-	-

3 P - Three Pole
4 P - Four Pole

Utilization Scope

Auto Transfer Switch is a self-acting equipment containing the transfer switching devices and other necessary devices for monitoring supply circuits and for transferring one or more load circuits from one supply to another.

The operating sequence of ATS consists of an automatic transfer of a load from the normal supply to an alternate supply in the event of a monitored supply deviation and automatically returning the load to the normal supply when quality of mains supply is restored. The transfer is with a predetermined time delay and includes an interim off position.

In case of both the normal and the alternate supplies being present, the ATS shall assume the normal supply position, which is termed as 'preferred supply'.

The various utilization categories show the most popular applications of Auto Transfer Switch, as per IEC-60947-6-1.

Nature of current	Utilization Category		Typical applications
	Operations A	Operations B	
Alternating Current	AC-31A	AC-31B	Non-inductive or slightly inductive loads Switching of mixed resistive and inductive loads, including moderate overloads Motor loads or mixed loads including motors, resistive loads and up to 30% incandescent lamp loads Electric discharge lamp loads Incandescent loads
	AC-32A	AC-32B	
	AC-33A	AC-33B	
	AC-35A AC-36A	AC-35B AC-36B	
Direct Current	DC-31A	DC-31B	Resistive loads Motor loads or mixed loads including motors Incandescent lamp load
	DC-33A	DC-33B	
	DC-36A	DC-36B	



Auto / Manual with Time Delay

Current Rating (A) Open Execution	Cat. No. 3 Pole	Cat. No. 4 Pole
100	IHYTSAO100	IHYFSAO100
160	IHYTSAO160	IHYFSAO160
200	IHYTSAO200	IHYFSAO200
315	IHYTSAO315	IHYFSAO315
400	IHYTSAO400	IHYFSAO400
630	IHYTSAO630	IHYFSAO630
In Enclosure		
100	IHYTSAE100	IHYFSAE100
160	IHYTSAE160	IHYFSAE160
200	IHYTSAE200	IHYFSAE200
315	IHYTSAE315	IHYFSAE315
400	IHYTSAE400	IHYFSAE400
630	IHYTSAE630	IHYFSAE630



Auto / Manual with Time Delay & Primary Protection		
Current Rating (A) Open Execution	Cat. No. 3 Pole	Cat. No. 4 Pole
100	IHYTPDO100	IHYFPDO100
160	IHYTPDO160	IHYFPDO160
200	IHYTPDO200	IHYFPDO200
315	IHYTPDO315	IHYFPDO315
400	IHYTPDO400	IHYFPDO400
630	IHYTPDO630	IHYFPDO630
In Enclosure		
100	IHYTPDE100	IHYFPDE100
160	IHYTPDE160	IHYFPDE160
200	IHYTPDE200	IHYFPDE200
315	IHYTPDE315	IHYFPDE315
400	IHYTPDE400	IHYFPDE400
630	IHYTPDE630	IHYFPDE630

Note : Primary side protections include single phasing, over voltage, under voltage. While the trip coil operates using 220V AC available from either of the electrical sources, the protection unit requires 12 DC battery input for its functioning. The same needs to be made available from an uninterrupted source such as external battery being used for self start generator set.

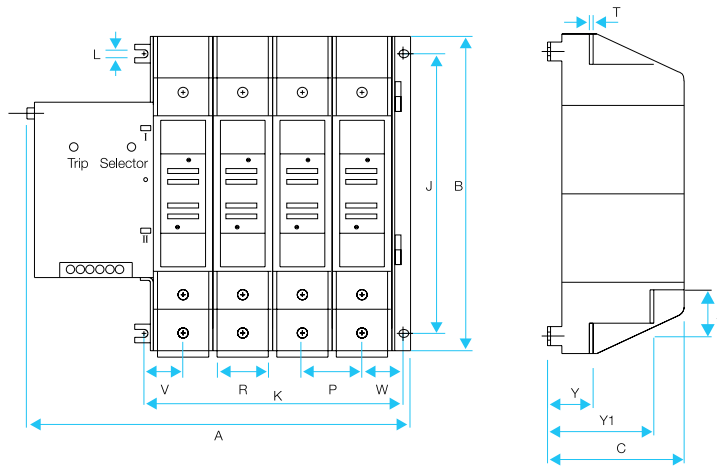

Dimensions (in mm) - Open Execution																		
Frame Size	Current Rating (A)	No. of Poles	Over All Dimensions			Switch Mounting			Connection Terminals							Terminal Bolt Size	Weight	
			A	B	C	J	K	L	P	R	S	T	V	W	Y			Y 1
1	100	3P	257	241	122	201	139	φ9	38	15	30	4	30	32	40	90	M8x30MM	8.3Kg
	100	4P	295	241	122	201	177	φ9	38	15	30	4	30	32	40	90	M8x30MM	9.3Kg
1	160	3P	257	241	122	201	139	φ9	38	15	30	4	30	32	40	90	M8x30MM	8.7Kg
	160	4P	295	241	122	201	177	φ9	38	15	30	4	30	32	40	90	M8x30MM	9.7Kg
2	200	3P	290	253	122	213	172	φ9	48	30	30	5	35	38	40	90	M8x30MM	10.5Kg
	200	4P	338	253	122	213	221	φ9	48	30	30	5	35	38	40	90	M8x30MM	11.5Kg
2	315	3P	290	253	122	213	172	φ9	48	30	30	5	35	38	40	90	M8x30MM	11.0Kg
	315	4P	338	253	122	213	221	φ9	48	30	30	5	35	38	40	90	M8x30MM	12.0Kg
3	400	3P	340	337	144	290	208	φ10	60	40	40	5	42	42	38	110	M10x40MM	19.5Kg
	400	4P	400	337	144	290	270	φ10	60	40	40	5	42	42	38	110	M10x40MM	21.0Kg
3	630	3P	340	337	144	290	208	φ10	60	44	40	7	42	42	38	110	M10x40MM	21.0Kg
	630	4P	400	337	144	290	270	φ10	60	44	40	7	42	42	38	110	M10x40MM	22.5Kg

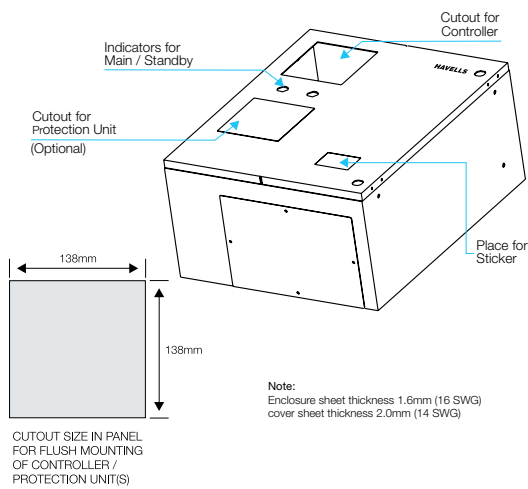
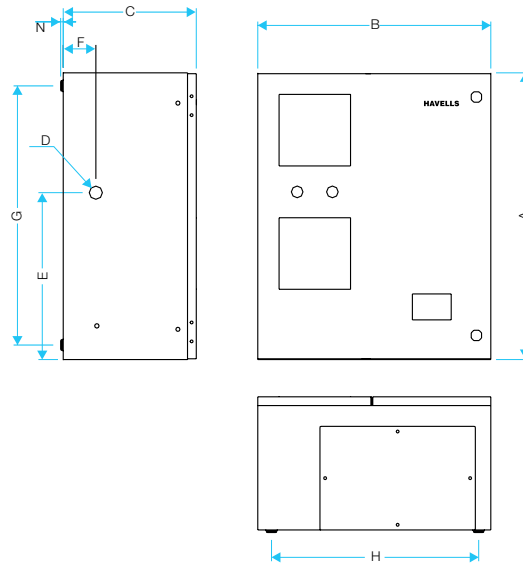

Dimensions (in mm) - in Enclosure									
Rating	A	B	C	D	E	F	G	H	N
100A-315A	550	450	255	φ 25.4	320	63	500	400	5
400A-630A	550	520	275	φ 25.4	328	68	500	470	5

Kompact Switch Disconnecter Fuse

Features:

- Front operated, positive break double isolation switch mechanism
- Multi Break arcing contacts per pole for higher electrical life
- Stationary Fuse Links prevent loosening of fuses
- Handle with Padlock, Door interlock and defeat mechanism facility
- Add-on auxiliary switch
- Available in open execution and in sheet steel enclosure.
- Suitable for Aluminium cable termination

Specification :

Conforms to IS/IEC:60947-1 & 3

Range :

- 32A to 800A with bolted type fuse links
- 32A to 800A with knife type fuse links
- 32A to 800A isolator version.

Execution :

- Single Pole with Switched Neutral
- Double Pole
- Triple Pole
- Triple Pole & Neutral
- Triple Pole with Switched Neutral
- Four Pole

A wide range of Front Operated Panel Mounting Switch Disconnecter Fuse are offered for various power distribution applications. These switches have high short circuit making and breaking capacity and are suitable for stringent AC-23A utilisation category. These can be used for both AC and DC applications.



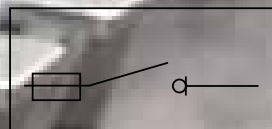



Havells SDF has been designed and developed to offer solutions sought by discerning customers where ease of installation and operation is required. The switches are compact and available in ratings 32A, 63A, 100A, 125A, 160A, 200A, 250A, 320A, 400A, 630A & 800A with both DIN type and BS type fuses conforming to IEC:947-3 and IS:13947-3. The switch is suitable for use in stringent AC 23-A applications.



The complete mechanism is enclosed in a fully insulated DMC moulded housing having excellent combination of mechanical & electrical properties. Phase barriers are provided for protection against phase to phase flashover.

The switches are designed for base mounting. All steel components are zinc plated, and current carrying parts are silver plated.

Operating Mechanism

Front handle operation makes possible concise and smaller panels. Sturdy operating handle incorporates features such as fool proof cover locking, inter lock with defeat facility, and padlocking for safety locking in OFF condition. Telescopic adjustable handle shaft is provided for maximum flexibility in order to suit varied mounting positions and to make them compatible to the bus bars.

Contacts and Contact Mechanism

The contact system comprises of knife type double break contact. These are supported by leaf spring.

Due to the quadrable break per pole (two each on incoming & outgoing), the fuses are positively isolated from both the ends in "OFF" position ensuring safety during maintenance. They are particularly advantageous in ring distribution network where the network is fed from both sides.

Enclosures

These switches are normally used in open execution for panel mounting. However, they are also available in enclosures. The enclosures are made of sheet steel which are robustly built, chemically phosphatized and electrostatically powder painted. They are ideally suited for adverse environmental conditions.



Technical Information



Frame Size				Size I		Size II	
Current Rating	I_e	A	32	63	100	125	
Rated Operational Voltage AC	U_e	V	415	415	415	415	
Rated Insulation Voltage	U_i	V	690	690	690	690	
Rated Impulse withstand Voltage	$U_{imp.}$	kV	8	8	8	8	
Rated Frequency		Hz	50	50	50	50	
Design temp./ Ambient Temp. Deg. C			40	40	40	40	
Utilization category			AC23A				
Rated Enclosed Thermal Current		A	32	63	100	125	
Rated Operational Power at 415V, 3ø		KW	23	36	58	72	
Making Capacity AC23A		A	320	630	1000	1250	
Breaking Capacity AC23A		A	256	504	800	1000	
Conditional short circuit current		KA_{rms}	80	80	80	80	
Rated Short-time withstand current (1 Sec, rms.)		KA	1.6	2	5	5	
Type of HBC Fuse links							
- BS Type			H-TIA	H-TSS	H-TSD	H-TSD	
- DIN Type			H-CD-00	H-CD-00	H-CD-00	H-CD-00	
Electrical Endurance		No. of Opers.	1500	1500	1500	1500	
Mechanical Endurance		No. of Opers.	10000	10000	10000	10000	
Temperature withstand range (Ambient)		°C	5 to 40	5 to 40	5 to 40	5 to 40	
Min. Cu cable section		Sq.mm	6	16	35	50	
Min. Al. cable section		Sq.mm	10	25	50	70	
Terminal Bolt Size Metric thread diameter x length		M6 x 16	M6 x 16	M6 x 16	M6 x 16	M6 x 16	
Weight	Open Execution	kg.	1.2	1.2	1.5	1.5	
	In Enclosure	kg.	4.2	4.2	4.5	4.5	

Technical Information

(Kompact Ezo)

216



Frame Size		Size III			Size IV		Size V	
Current Rating		160A	200A	250A	320A	400A	630A	800A
No. of Poles		TPN & FP						
Rated operational Voltage (U_e)	V	415	415	415	415	415	415	415
Rated Insulation Voltage (U_i)	V	690	690	690	690	690	690	690
Rated Frequency	Hz	50	50	50	50	50	50	50
Rated impulse withstand voltage (U_{imp})	kV	8	8	8	8	8	8	8
Utilization Category		AC 23A						
Rated making capacity	A	1600	2000	2500	3200	4000	6300	8000
Rated breaking capacity	A	1280	1600	2000	2560	3200	5040	6400
Rated fused short-circuit current (I_{cn})								
With Havells fuses	kA	80	80	80	80	80	80	80
Capacitor duty-Connected-415V, 50-60 Hz	kVAr	57	92	115	145	175	250	270
Endurance (operations) Mechanical	Nos.	8000	8000	8000	5000	5000	5000	3000
Endurance (operations) Electrical	Nos.	1000	1000	1000	1000	1000	1000	500
Rated Short-time withstand current (I_{cw}) with shorted links for 1.0 sec.	KArms	5	5	5	10	10	10	10
Type of HBC Fuse links								
- BS type		B2	B2	B3	B3	B4	C2	C3
- DIN type		Size 1	Size 1	Size 1	Size 2	Size 2	Size 3	Size 3
Min. Cu cable section	Sq.mm	70	95	120	185	240	40x5x2 (Bus Bar)	50x5x2 (Bus Bar)
Min. Al. cable section	Sq.mm	95	150	185	240	300	40x8x2 (Bus Bar)	50x8x2 (Bus Bar)
Terminal Screw	mm	M10x30	M10x30	M10x30	M10x30	M10x30	M10x30	M10x30
Aprox Wt. of TP Switch (without fuse links)	Kg	6.1	6.1	6.1	12.5	12.5	17.0	17.0

* TPN - Three Pole & Neutral; FP - Four Pole
For ratings 630A and above, bus bar termination is required

Switch can be used for DC application upto 250V by using 2 poles in series.

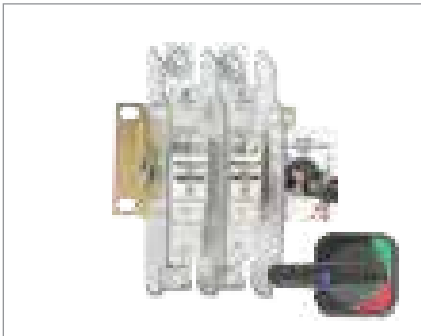

Double Pole Size 1				
Current Rating (A)	Open Execution Cat No.	Open Execution with Fuse Cat No.	In S/S Enclosure with Fuse Cat No.	HBC Fuse Type Cat No.
32	IHFDDO4032	IHFDDF4032	IHFDDW4032	IHHTIA0032
32	IHFFDO4032	IHFFDF4032	IHFFDW4032	IHHCD00032
63	IHFDDO4063	IHFDDF4063	IHFDDW4063	IHHTSS0063
63	IHFFDO4063	IHFFDF4063	IHFFDW4063	IHHCD00063

Double Pole Size 2				
Current Rating (A)	Open Execution Cat No.	Open Execution with Fuse Cat No.	In S/S Enclosure with Fuse Cat No.	HBC Fuse Type Cat No.
100	IHFDDO4100	IHFDDF4100	IHFDDW4100	IHHTSD0100
100	IHFFDO4100	IHFFDF4100	IHFFDW4100	IHHCD00100
125	IHFDDO4125	IHFDDF4125	IHFDDW4125	IHHTSD0125
125	IHFFDO4125	IHFFDF4125	IHFFDW4125	IHHCD00125



Three Pole & Neutral Size 1				
Current Rating (A)	Open Execution Cat No.	Open Execution with Fuse Cat No.	In S/S Enclosure with Fuse Cat No.	HBC Fuse Type Cat No.
32	IHFDTO4032	IHFDTF4032	IHFDTW4032	IHHTIA0032
32	IHFFTO4032	IHFFTF4032	IHFDTW4032	IHHCD00032
63	IHFDTO4063	IHFDTF4063	IHFDTW4063	IHHTSS0063
63	IHFFTO4063	IHFFTF4063	IHFFTW4063	IHHCD00063

Three Pole & Neutral Size 2				
Current Rating (A)	Open Execution Cat No.	Open Execution with Fuse Cat No.	In S/S Enclosure with Fuse Cat No.	HBC Fuse Type Cat No.
100	IHFDTO4100	IHFDTF4100	IHFDTW4100	IHHTSD0100
100	IHFFTO4100	IHFFTF4100	IHFFTW4100	IHHCD00100
125	IHFDDO4125	IHFDTF4125	IHFDTW4125	IHHTSD0125
125	IHFFTO4125	IHFFTF4125	IHFFTW4125	IHHCD00125

Three Pole & Neutral - Kompact Ezo Size 5				
Current Rating (A)	Open Execution Cat No.	Open Execution with Fuse Cat No.	In S/S Enclosure with Fuse Cat No.	HBC Fuse Type Cat No.
630	IHFSTO4630	IHFSTF4630	IHFSTW4630	IHHTLM0630
630	IHFKTO4630	IHFKTF4630	IHFKTW4630	IHHCD03630
800	IHFSTO4800	IHFSTF4800	IHFSTW4800*	BS Type
800	IHFKTO4800	IHFKTF4800	IHFKTW4800*	Din Type

* FSTW4800 and FKTW4800 are without Fuse Links



Three Pole & Neutral - Kompact Ezo Size 3 & 4				
Current Rating (A)	Open Execution Cat No.	Open Execution with Fuse Cat No.	In S/S Enclosure with Fuse Cat No.	HBC Fuse Type Cat No.
160	IHFSTO4160	IHFSTF4160	IHFSTW4160	IHHTSF0160
160	IHFKTO4160	IHFKTF4160	IHFKTW4160	IHHCD01160
200	IHFSTO4200	IHFSTF4200	IHFSTW4200	IHHTSF0200
200	IHFKTO4200	IHFKTF4200	IHFKTW4200	IHHCD01200
250	IHFSTO4250	IHFSTF4250	IHFSTW4250	IHHTSF0250
250	IHFKTO4250	IHFKTF4250	IHFKTW4250	IHHCD01250
315	IHFSTO4320	IHFSTF4320	IHFSTW4320	IHHTSK0315
315	IHFKTO4320	IHFKTF4320	IHFKTW4320	IHHCD02315
400	IHFSTO4400	IHFSTF4400	IHFSTW4400	IHHTSMF400
400	IHFKTO4400	IHFKTF4400	IHFKTW4400	IHHCD02400



Four Pole Size 1 & 2				
Current Rating (A)	Open Execution Cat No.	Open Execution with Fuse Cat No.	In S/S Enclosure with Fuse Cat No.	HBC Fuse Type Cat No.
32	IHFDFO4032	IHFDF4032	IHFDFW4032	IHHTIA0032
32	IHFFFO4032	IHFFFF4032	IHFFFW4032	IHHCD00032
63	IHFDFO4063	IHFDF4063	IHFDFW4063	IHHTSS0063
63	IHFFFO4063	IHFFFF4063	IHFFFW4063	IHHCD00063
100	IHFDFO4100	IHFDF4100	IHFDFW4100	IHHTSD0100
100	IHFFFO4100	IHFFFF4100	IHFFFW4100	IHHCD00100
125	IHFDFO4125	IHFDF4125	IHFDFW4125	IHHTSD0125
125	IHFFFO4125	IHFFFF4125	IHFFFW4125	IHHCD00125

Four Pole - Kompact Ezo Size 3				
Current Rating (A)	Open Execution Cat No.	Open Execution with Fuse Cat No.	In S/S Enclosure with Fuse Cat No.	HBC Fuse Type Cat No.
160	IHFSTO4160	IHFSTF4160	IHFSTW4160	IHHTSF0160
160	IHFKFO4160	IHFKFF4160	IHFKFW4160	IHHCD01160
200	IHFSTO4200	IHFSTF4200	IHFSTW4200	IHHTSF0200
200	IHFKFO4200	IHFKFF4200	IHFKFW4200	IHHCD01200
250	IHFSTO4250	IHFSTF4250	IHFSTW4250	IHHTSF0250
250	IHFKFO4250	IHFKFF4250	IHFKFW4250	IHHCD01250

Four Pole - Kompact Ezo Size 4 & 5				
Current Rating (A)	Open Execution Cat No.	Open Execution with Fuse Cat No.	In S/S Enclosure with Fuse Cat No.	HBC Fuse Type Cat No.
320	IHFSTO4320	IHFSTF4320	IHFSTW4320	IHHTSK0315
320	IHFKFO4320	IHFKFF4320	IHFKFW4320	IHHCD02315
400	IHFSTO4400	IHFSTF4400	IHFSTW4400	IHHTSMF400
400	IHFKFO4400	IHFKFF4400	IHFKFW4400	IHHCD02400
630	IHFSTO4630	IHFSTF4630	IHFSTW4630	IHHTLM0630
630	IHFKFO4630	IHFKFF4630	IHFKFW4630	IHHCD03630
800	IHFSTO4800	IHFSTF4800	IHFSTW4800*	BS Type
800	IHFKFO4800	IHFKFF4800	IHFKFW4800*	Din Type

* FSTW4800 and FKTW4800 are without Fuse Links

Dimensions (in mm)

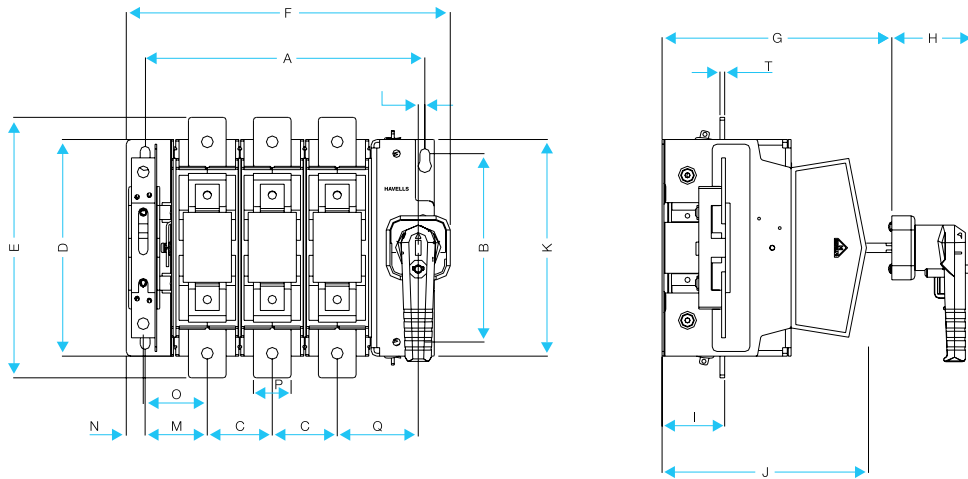

Rating	Type	A	B	C	D	E	F	G	H	I	J	K	L	M	N	O	P	Q	T
32A to 63A	DP	100	60	34	75	117	148	150-225	86.5	40	137	74	2	30	9	32	12	38	2
	TPN	134	60	34	75	117	182	150-225	86.5	40	137	74	2	30	9	32	12	38	2
	FP	168	60	34	75	117	216	150-225	86.5	40	137	74	2	30	9	32	12	38	2
100A to 125A	DP	100	60	34	107	156	148	150-225	86.5	40	137	74	2	30	9	32	20	38	2
	TPN	134	60	34	107	156	182	150-225	86.5	40	137	74	2	30	9	32	20	38	2
	FP	168	60	34	107	156	216	150-225	86.5	40	137	74	2	30	9	32	20	38	2
160A to 250A	TPN	235	159	57	190	190	284	203	86.5	50	174	179	4	48.5	19	51.5	30	68.5	4
	FP	292	159	57	190	190	341	203	86.5	50	174	179	4	84.5	19	51.5	30	68.5	4
320 to 400A	TPN	302	200	70	230	282	349	260	86.5	67	212	230	7	70	20	67.5	40	85	5
	FP	372	200	70	230	282	419	260	86.5	67	212	230	7	70	20	67.5	40	85	5
630A	TPN	340	200	82.5	240	285	387	290	86.5	71	261	230	7	74	20	78.5	50	94	7
	FP	422.5	200	82.5	240	285	469.5	290	86.5	71	261	230	7	74	20	78.5	50	94	7

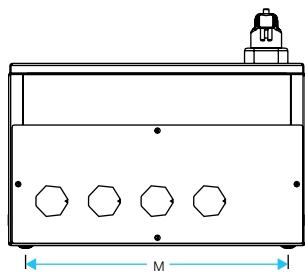
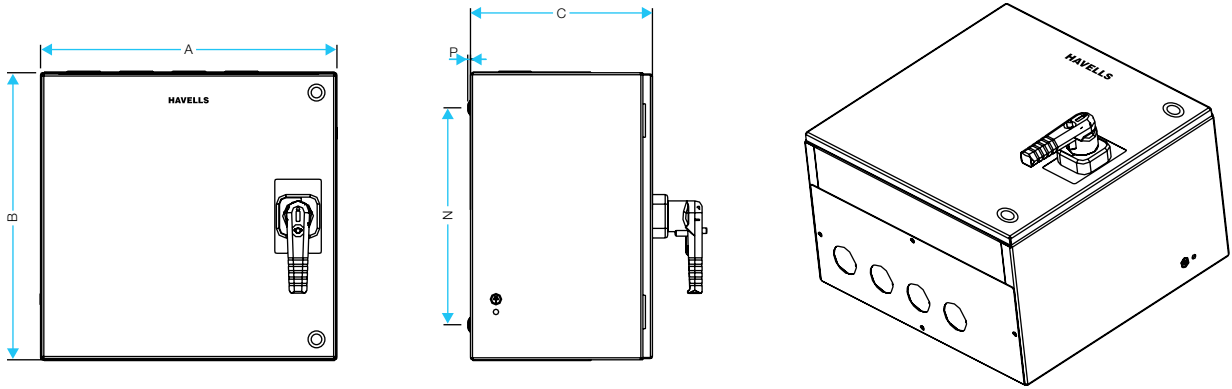

In Enclosure						
Ratings	A	B	C	M	N	P
32A-125A	250	230	160	200	180	5
160A-250A	350	300	210	300	240	5
320A-400A	430	355	260	350	290	5
630A-800A	465	450	290	412	340	5

Door Interlock

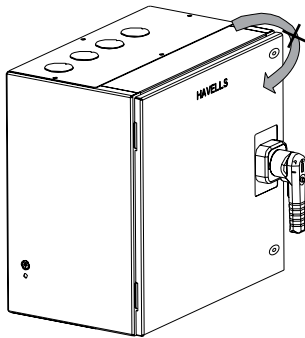

The Handle allows opening of the door in off condition only. In ON position, the door cannot be opened. The interlock can however be by-passed (defeat option on the handle) for maintenance / testing / commissioning. The interlock is restored automatically, on reclosing the panel door

Defeat Facility

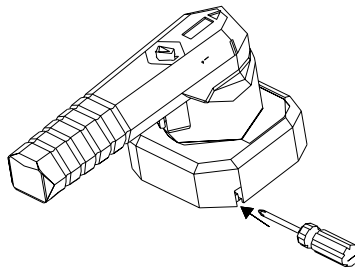

For safety reasons the door cannot be opened when the handle is padlocked. The defeat function allows qualified personnel to by-pass the door interlock when the switch is in on position.

Padlocking

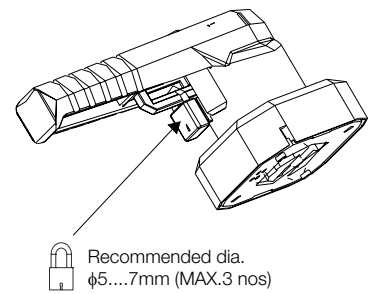

Handle can be padlocked in OFF position as well as in ON position

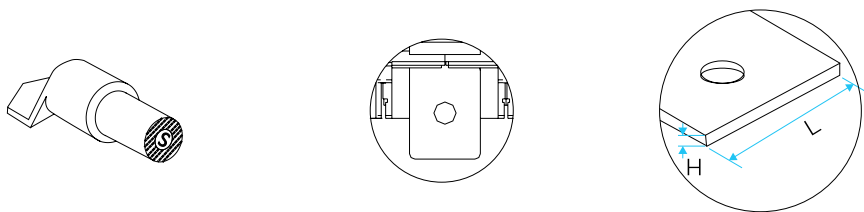

Aluminium / Copper Cable / Bus Bar Size for External Termination							
I_n	ϕT	Nm	S max. (Al)mm ²	S max. (Cu)mm ²	H (Cu)mm	L (Cu)mm	Switch mounting Fastner
32 A	M6	3.7	10	6	2	12	M6 x 12
63 A	M6	3.7	25	16	2	12	
100 A	M8	9	50	35	2	20	
125 A	M8	9	70	50	2	20	
160 A	M10	48	95	70	4	30	M6 x 15
200 A	M10	48	150	95	4	30	
250 A	M10	48	185	120	4	30	
320 A	M10	48	240	185	5	40	
400 A	M10	48	300	240	5	40	
630 A	M10	48	2x40x8	2x40x5	7	50	
800 A	M12	48	2x50x8	2x50x5	7	50	

Switch mountings and fitments have been detailed in installation sheets which are supplied with every switch.

Euroload Switch Disconnecter

Features:

- High electrical & mechanical endurance
- Suitable for Copper and Aluminium cable lug termination
- Contacts and mechanism in enclosed housing to avoid dust ingress
- Double break contacts per pole
- Arc chutes and Arc barriers provided
- Staggered terminals for cable termination upto 400A/ 800A in 3 pole/4 pole execution
- Provision of Phase separators
- Easy add-on Auxiliary switch kit
- Separate main & arcing contacts
- Handle with door interlock and padlock facility.
- Front operated with two stable position : 0 - 1

Range :

- 80A to 400A in 2 frame sizes in 3 pole .
- 40A to 3150A in 7 frame sizes in 4 pole execution with advance neutral.

Specification :

Conforms to IS / IEC:60947-1&3

A comprehensive range of Euroload Switch Disconnecter (Load Break Switches) have been designed and developed indigenously to meet various needs of distribution circuits. The switches are compact and suitable for AC-23A duty.



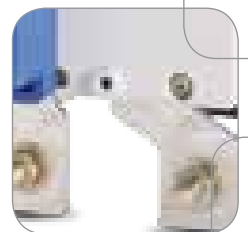

Construction

224



The switching mechanism is quick make, quick break type independent of the speed of the operation. There are four breaks per pole thereby resulting into faster quenching of arc. The load and line can be connected on either side by virtue of isolation on both the sides. The entire switching mechanism alongwith the fixed and moving contact assembly are housed in a polyester reinforced, moulded frame/cover, having high dielectric strength & thermal withstand capacity.

Contact Mechanism

The contact mechanism is knife blade type with self cleaning action during operation. The fixed contact terminals in each phase have separate main and arcing contacts. The moving contact assembly has three/four sets of contacts on moving carrier and the entire assembly rests on the spring loaded steel balls fitted in moving carrier in rating upto 320A and spring loaded buttons which assists in its true movement during making and breaking.

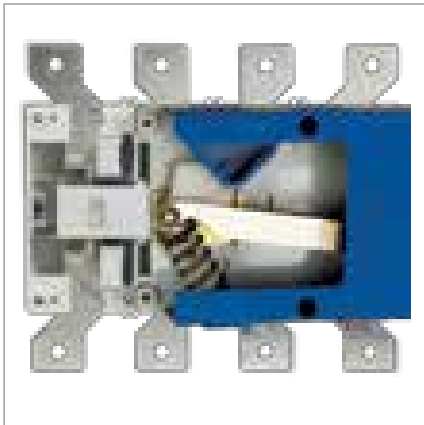

The moving contact mates with the fixed contact by a roll and slide movement of the moving contact assembly. The contact is first made with the arcing contact and thereafter with the main contact. During breaking, the arc formation is across the arcing contacts thereby protecting the main contacts which results into enhanced life of the switch. The arc is effectively quenched & confined by the set of arc chutes / arc barrier in each phase.

The switches can be mounted inside a panel either in horizontal or vertical mode without any effect on the performance.

Operating Mechanism

The operating mechanism consists of single/double side front operated handle which drives the spring assisted toggle mechanism, inturn operating the switch.

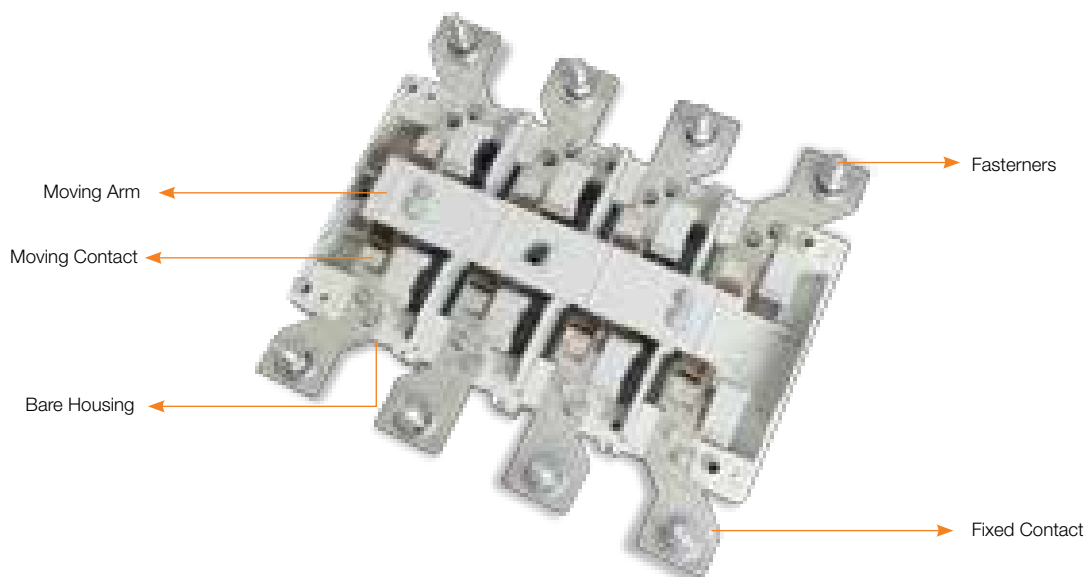

Technical Information

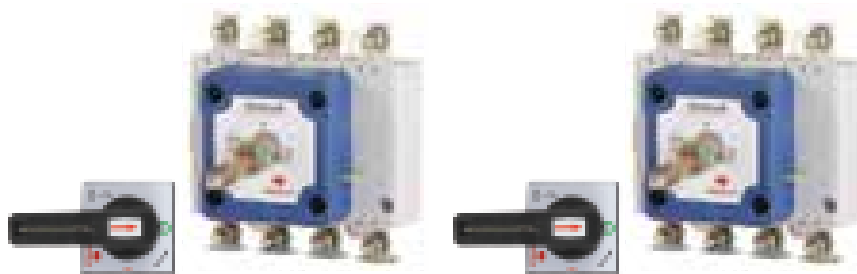

Frame Size			Size 00			
Rated operated Current at 40°C	I_e	A	40	63	80	100
Nos. of Poles			4	4	4	4
Rated Operational Voltage	U_e	V	415	415	415	415
Rated Insulation Voltage	U_i	V	1000	1000	1000	1000
Rated Impulse Voltage	$U_{imp.}$	kV	8	8	8	8
Dielectric strength, 50 Hz,	V_{im}	kV	5	5	5	5
Pollution Degree			3	3	3	3
Rated Current - AC 415V						
AC23A		A	40	63	80	100
Rated Operational Power	415V AC	KW	23	36	46	58
Making Capacity AC23A	415V	A	400	630	800	1000
Breaking Capacity AC23A	415V	A	320	504	640	800
Conditional Short ckt current	415V AC	KA_{rms}	80	80	80	80
Fuse Ratings gG		A	40	63	80	100
Rated Short Time Withstand Current for 1 Sec. rms value		KA_{rms}	5	5	5	5
Mechanical Endurance	opers.		10000	10000	10000	10000
Electrical Endurance	opers.		1500	1500	1500	1500
Min. Cu cable section	Sq.mm		10	16	25	35
Min. Al. cable section	Sq.mm		16	25	35	50
Terminal Bolt Size						
Metric thread diameter x length		mm	M6 X 16			
Overall Dimensions H X W X D			mm			
			105 X 122 X 101			
Weight	Open Execution	kg.	0.8	0.8	0.9	0.9
	In Enclosure	kg.	1.9	1.9	2.0	2.0

Technical Information

Catalogue No.	Size-0					
Current Rating	A	80	100	125	160	200
Nos. of Poles		3	3	3/4	3/4	3/4
Rated insulation voltage, U_i	V	1000	1000	1000	1000	1000
Rated operational voltage, U_e	V	415	415	415	415	415
Dielectric strength, 50 Hz, V_{im}	KV	5	5	5	5	5
Rated impulse withstand voltage, U_{imp}	KV	8	8	8	8	8
Rated making capacity Amp, 436V AC23A, p.f.- 0.45 (80A) / = 0.35 ($I_e \geq 100A$)		800	1000	1250	1600	2000
Rated breaking capacity Amp, 436V AC23A, p.f.- 0.45 (80A) / = 0.35 ($I_e \geq 100A$)		640	800	1000	1280	1600
Rated Operational Power 415V, 3 ϕ	kW	46	58	72	92	115
Rated conditional short circuit current	kA_{rms}	80	80	80	80	80
Max. Allowed cut off current	kA_{peak}	12	15	17	18	22
Rated short time withstand current (1sec.)	kA_{rms}	7.5	7.5	7.5	7.5	7.5
Electrical Durability						
Nos. of operating cycles AC-23A		1500	1500	1000	1000	1000
Mechanical Durability						
Nos. of no load operating cycles		10000	10000	8000	8000	8000
Temperature withstand range (ambient)	$^{\circ}C$	-5 to 50	-5 to 50	-5 to 50	-5 to 50	-5 to 50
Terminal connection						
Al. Cable /Bus Bar cross section	mm^2	35	50	70	95	150
Cu. Cable /Bus Bar cross section	mm^2	25	35	50	70	95
Weight						
Open Execution	Kg.	1.4	1.4	1.4/1.8	1.6/2.0	1.6/2.0
In Enclosure	Kg.	4.0	4.0	4.0/6.0	4.2/6.2	4.2/6.2

Frame Size		Size I		Size II		Size III
Current Rating	A	250	320	400	630	800
Nos. of Poles		3/4	3/4	4	4	4
Rated insulation voltage, U_i	V	1000	1000	1000	1000	1000
Rated operational voltage, U_e	V	415	415	415	415	415
Dielectric strength, 50 Hz, V_{im}	KV	5	5	8	8	10
Rated impulse withstand voltage, U_{imp}	KV	8	8	8	8	8
Rated making capacity Amp, 436V AC23A, p.f.- 0.35		2500	3200	4000	6300	8000
Rated breaking capacity Amp, 436V AC23A, p.f.- 0.35		2000	2550	3200	5100	6400
Rated Operational Power 415V, 3 ϕ	kW	144	184	230	362	460
Rated conditional short circuit current	kA_{rms}	80	80	80	80	80
Max. Allowed cut off current	kA_{peak}	27	33	39	55	70
Rated short time withstand current (1sec.)	kA_{rms}	15	15	30	30	35
Electrical Durability						
Nos. of operating cycles AC-23A		1000	1000	1000	1000	500
Mechanical Durability						
Nos. of no load operating cycles		8000	5000	5000	5000	3000
Temperature withstand range (ambient)	$^{\circ}C$	-5 to 50	-5 to 50	-5 to 50	-5 to 50	-5 to 50
Terminal connection						
Al. Cable /Bus Bar cross section	mm^2	185	240	300	40x8x2	50x8x2
Cu. Cable /Bus Bar cross section	mm^2	120	185	240	40x5x2	50x5x2
Weight						
Open Execution	Kg.	2.8/3.6	3.1/3.9	3.1	8.20	11.80
In Enclosure	Kg.	10.0/13.1	10.0/13.4	10.0	23.90	28.00

* For ratings 630A & above bus bar terminals in recommended.

Technical Information

Frame Size		Size IV			Size V		
Current Rating	A	1000	1250	1600	2000	2500	3150
Nos. of Poles		4	4	4	4	4	4
Rated insulation voltage, U_i	V	1000	1000	1000	1000	1000	1000
Rated operational voltage, U_e	V	415	415	415	415	415	415
Dielectric strength, 50 Hz, V_m	KV	10	10	10	10	10	10
Rated impulse withstand voltage, U_{imp}	KV	8	8	8	8	8	8
Rated operational current, I_e at 415V AC 23A	A	1000	1250	1600	2000	2500	3150
Rated making capacity Amp, 436V AC23A, p.f.- 0.35		10000	12500	16000	20000	25000	30500
Rated breaking capacity Amp, 436V AC23A, p.f.- 0.35		8000	10000	12800	16000	20000	25200
Rated operational power at 415V, 3 ϕ	kW	575	519	920	1150	1438	1811
Rated conditional short circuit current	kA _{rms}	80	80	80	80	80	80
Electrical Durability							
Nos. of operating cycles AC-23A		500	500	500	500	500	500
Mechanical Durability							
Nos. of no load operating cycles		3000	3000	3000	3000	3000	2000
Temperature withstand range (ambient)	°C	-5 to 50	-5 to 50	-5 to 50	-5 to 50	-5 to 50	-5 to 50
Terminal connection							
Al. Cable /Bus Bar cross section	mm ²	50x10x2	63x12x2	50x8x4	100x10x3	100x10x4	150x10x4
Cu. Cable /Bus Bar cross section	mm ²	60x5x2	80x5x2	100x5x2	100x5x3	100x5x4	100x10x3
Weight							
Open Execution	Kg.	22.00	23.70	25.00	45.00	51.20	58.60
In Enclosure	Kg.	52.00	53.50	55.00	**	**	**

** Details on request



Size 00 (Four Pole)		
Current Rating (A)	Open Execution Cat. No.	In Enclosure Cat. No.
40	IHCSFO0040	IHCSFE0040
63	IHCSFO0063	IHCSFE0063
80	IHCSFO0080	IHCSFE0080
100	IHCSFO0100	IHCSFE0100

Size 0 (Three Pole)		
Current Rating (A)	Open Execution Cat. No.	In Enclosure Cat. No.
80	IHCSTO0080	IHCSTE0080
100	IHCSTO0100	IHCSTE0100
125	IHCSTO0125	IHCSTE0125
160	IHCSTO0160	IHCSTE0160
200	IHCSTO0200	IHCSTE0200

Size 1 (Three Pole)		
Current Rating (A)	Open Execution Cat. No.	In Enclosure Cat. No.
250	IHCSTO0250	IHCSTE0250
320	IHCSTO0320	IHCSTE0320
400	IHCSTO0400	IHCSTE0400

Size 0 (Four Pole)		
Current Rating (A)	Open Execution Cat. No.	In Enclosure Cat. No.
125	IHCSFO0125	IHCSFE0125
160	IHCSFO0160	IHCSFE0160
200	IHCSFO0200	IHCSFE0200



Size 1 (Four Pole)		
Current Rating (A)	Open Execution Cat. No.	In Enclosure Cat. No.
250	IHCSFO0250	IHCSFE0250
320	IHCSFO0320	IHCSFE0320

Size 2		
Current Rating (A)	Open Execution Cat. No.	In Enclosure Cat. No.
400	IHCSFO0400	IHCSFE0400
630	IHCSFO0630	IHCSFE0630

Size 3		
Current Rating (A)	Open Execution Cat. No.	In Enclosure Cat. No.
800	IHCSFO0800	IHCSFE0800

Size 4		
Current Rating (A)	Open Execution Cat. No.	In Enclosure Cat. No.
1000	IHCSFO1000	IHCSFE1000
1250	IHCSFO1250	IHCSFE1250
1600	IHCSFO1600	IHCSFE1600

Size 4		
Current Rating (A)	Open Execution Cat. No.	In Enclosure Cat. No.
2000	IHCSFO2000	IHCSFE2000
2500	IHCSFO2500	IHCSFE2500
3150	IHCSFO3150	IHCSFE3150

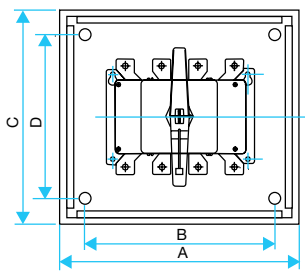

Upto 800A

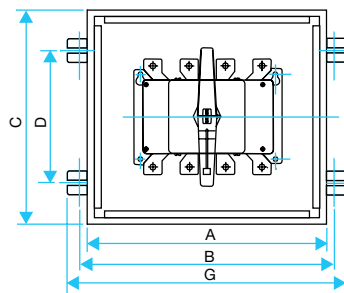

1000A to 3150A

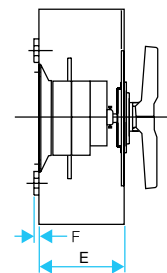

DIMENSIONS (in mm) - ENCLOSURE							
CURRENT (A)	A	B	C	D	E	F	G
80/100/125/160/200 A TP	270	220	290	188	150	5	-
250/320/400 A TP	310	260	380	230	160	5	-
40/63/80/100 A FP	210	160	200	150	100	5	-
125/160/200 A FP	270	210	290	188	150	5	-
250/320 A FP	310	250	380	250	160	5	-
400/630 A FP	475	415	425	365	210	5	-
800 A FP	520	470	480	430	230	5	-
1000/1250/1600 A FP	730	770	630	480	300	6	810
2000/2500/3150 A FP	730	770	800	560	430	6	810

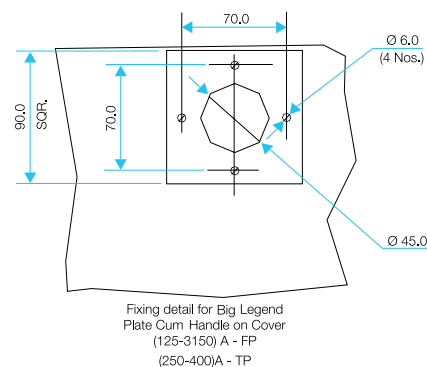
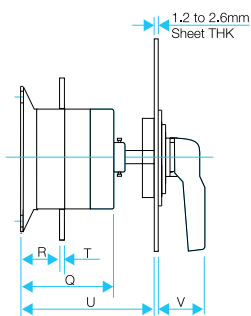
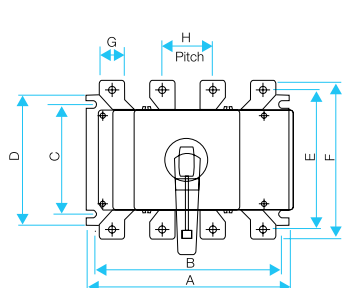
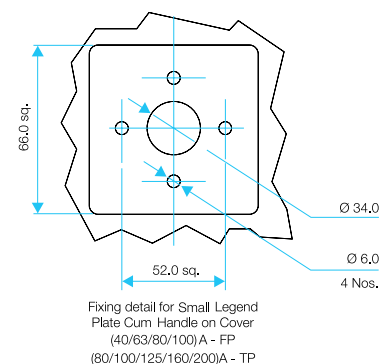
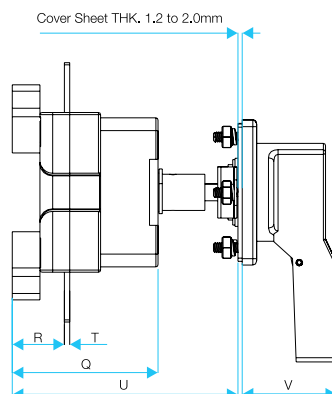
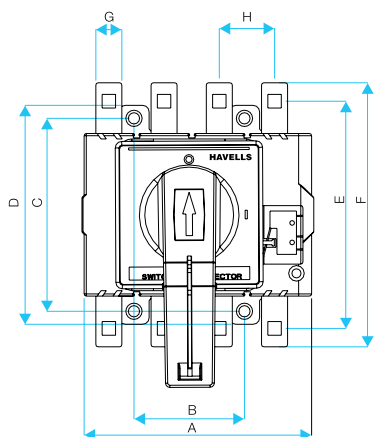

DIMENSIONS (in mm) - OPEN EXECUTION													
CURRENT (A)	A	B	C	D	E	F	G	H	Q	R	T	U	V
80/100/125 A TP	136	122	113	132	124	148	15	34	90	36	3.2	148	44
160 A TP	136	122	113	132	124	148	24	34	90	36	3.2	148	62
200 A TP	136	122	113	132	124	148	24	52	90	36	3.2	148	62
250 A TP	186	172	134	156	147	177	28	58	112	40	4	158	62
320 A TP	186	172	134	156	165	198	35	63	112	40	4	158	62
400 A TP	186	172	134	156	165	198	35	63	109	40	4	158	62
40/63 A FP	105	51	89	101	93	110	12	26	68	24	2.5	98	44
80/100 A FP	105	51	89	101	105	122	12	26	68	24	3.2	98	44
125 A FP	170	156	113	132	122	148	20	46	90	37.5	3.2	148	62
160/200 A FP	170	156	113	132	122	148	24	46	90	37.5	3.2	148	62
250 A FP	234	220	134	156	147	177	28	58	110	40	4	158	62
320 A FP	234	220	134	156	165	198	35	63	110	40	4	158	62
400 A FP	325	297	184	206	221	251	40	80	134	47	5	208	62
630 A FP	325	297	184	206	241	281	55	80	134	47	5	208	62
800 A FP	368	336	212	234	280	331	45	97	144	52	8	215	62
1000 A FP	480	440	290	315	340	380	70	100	204	101	10	276	62
1250 A FP	480	440	290	315	340	380	70	100	204	101	12	276	62
1600 A FP	480	440	290	315	340	380	70	100	204	101	15	276	62
2000/2500/3150 A FP	480	440	290	315	387	480	80	100	308	74	15	402	62

Fuse Link

Features:

- Excellent AC and DC performance
- Low watt loss
- Interchangeable with compatible brands
- ISI Marked

Range :

- 2A-800A in Bolted design (BS type)
- 6A-630A in Blade Contact design (DIN type)
- 4A-63A in Round Head design (RH type)

Specification :

Conforms to IEC:60269-1 & 2-1 / IS:13703-1 & 2-1

HiBreak range of low voltage fuse links have been designed to meet the requirements set for modern industrial installations & electrical power plants. Their breaking capacity is sufficient even for the highest short circuit levels, which are normally reached in practice.

The breaking capacity of the fuse links is 80KA at 415AC. The fuse links are suitable for use in both AC/DC applications for over current and short circuit protection and have very low let through energy resulting in reduced electro magnetic stress and reliable short circuit clearance.

They have excellent non-deterioration performance and low power loss values well within the limits of the specification.



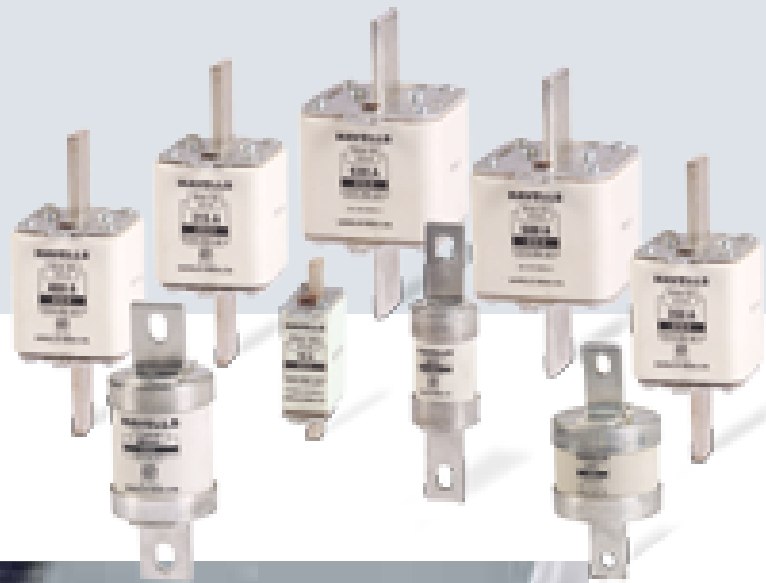

Technical Information



Type	BS (Bolted Connection)	DIN (Blade Contact)	RH (Cylindrical Cap)
Rated Voltage	415 V	415 V	415 V
Rated Current	2A - 800A*	6A - 630A*	4A - 63A*
Rated Frequency	50Hz	50Hz	50Hz
Breaking Capacity	80KA	80KA	80KA
Utilization Category	"gG"	"gG"	"gG"
Non Fusing Current	1.25In	1.25In	1.25In
Fusing Current	1.6In	1.6In	1.6In
Size	F-1, A-2, A-3, A-4 B-1, B2, B-3, B-4 C-1, C-2, C-3	CD-000, CD-00, CD-1, CD-2, CD-3	--
Cut-off Characteristics	As per specification	As per specification	As per specification
Material of Body	Steatite ceramic	Steatite ceramic	Steatite ceramic
Material of the Fusing Element	Copper with Tin Solder	Copper with Tin Solder	Copper with Tin Solder
Material of Filler	Silica Quartz	Silica Quartz	Silica Quartz
Material of Blade	Brass (6A - 63A) Copper (80A - 630A)	Brass (6A - 400A) Copper (425-630A)	--
Indication of Blown Fuse	--	Provided	--

* Current Ratings : 2A, 4A, 6A, 10A, 16A, 20A, 25A, 32A, 40A, 50A, 63A, 80A, 100A, 125A, 160A, 200A, 250A, 315A, 350A, 400A, 425A, 500A, 630A, 800A.

Time Current Characteristic Curve

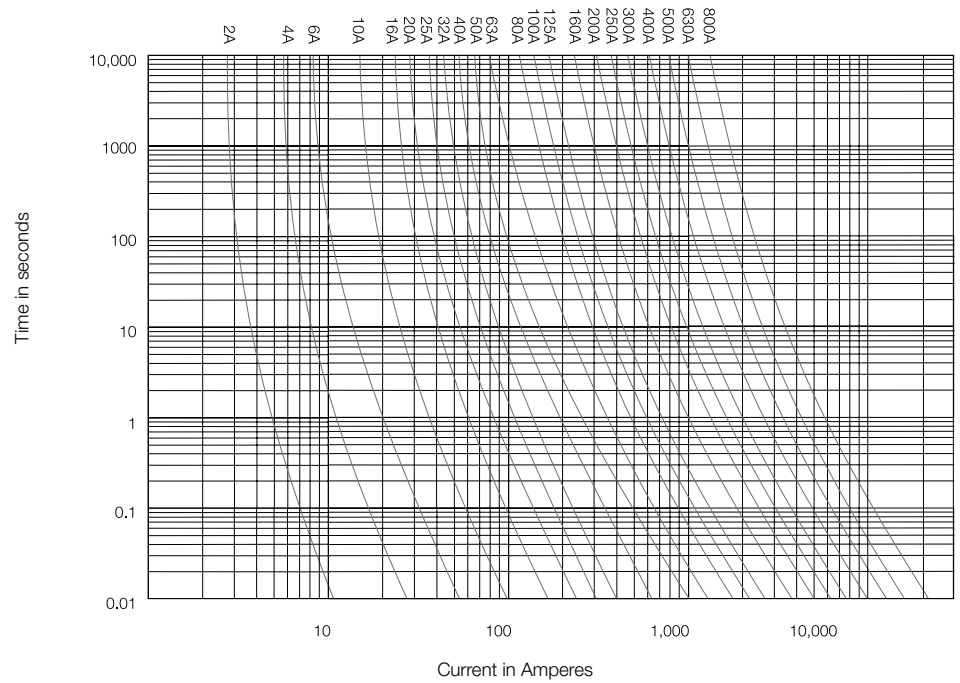

Current Limitation

Fuses are of current limiting design & hence the short circuit currents cannot rise to the full prospective value owing to the very short clearing time. Adverse effects of the short circuit on the switchgear are thus prevented.

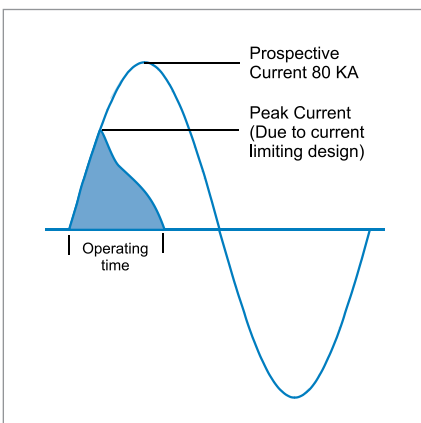

Discrimination

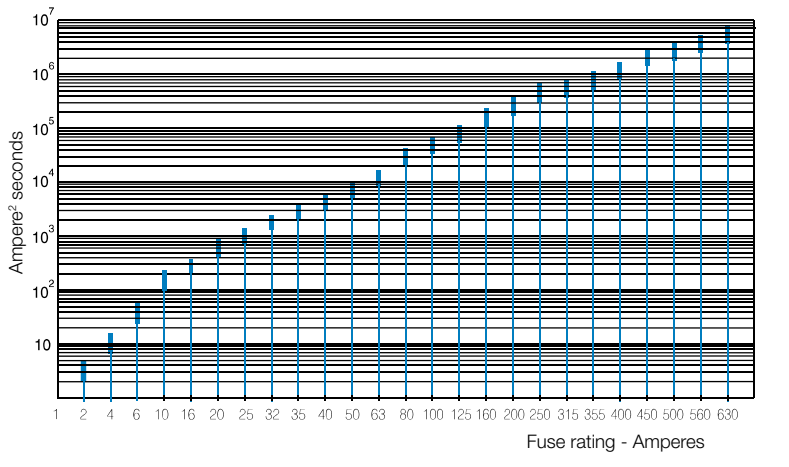

Total operating I²t

Pre-arcing I²t

Positive discrimination under short-circuit conditions is achieved when the higher rated fuse link is unaffected by the fault current, which can cause the lower rated fuse link to operate. The total operating I²t let through by the lower rated fuse link must be less than the pre-arcing I²t of the higher fuse link.

The I²t characteristics of fuse links with a prospective current upto 80 KA, 0.15 power factor and at 415V AC, is shown for quick selection.

Fuse Selection Table for Motors

Direct On Line Starting			Star Delta Starting		
Motor Rating 3φ, 415V, 50 Hz		Recommended Fuse Link (Amp)	Motor Rating 3φ, 415V, 50Hz		Recommended Fuse Link (Amp)
kW	HP		kW	HP	
0.37	0.5	4	2.2	3	6
0.55	0.75	4	3.7	5	10
0.75	1	6	5.5	7.5	16
1.1	1.5	6	7.5	10	20
1.5	2	10	9.3	12.5	25
2.2	3	16	11	15	25
3.7	5	20	15	20	32
5.5	7.5	25	18.5	25	50
7.5	10	25	22	30	50
9.3	12.5	32	30	40	63
11	15	50	37	50	80
15	20	63	45	60	100
18.5	25	80	55	75	100
22	30	100	75	100	160
30	40	125	90	125	160
37	50	125	110	150	200
45	60	160	132	180	250
55	75	160	160	215	315
75	100	200	200	270	400
90	125	250	250	335	400
110	150	315			
132	180	400			
160	215	400			
200	270	500			
250	335	500			



Bs Type with Bolted Connection		
Current Rating (A)	Type	Cat. No.
2, 4, 6, 10, 16, 20, 25, 32	Offset	IHHNS00002-032
2, 4, 6, 10, 16, 20, 25, 32	Offset	IHHTIA0002-032
36, 40, 50, 63	Offset	IHHTSS0036-063
80, 100, 125	Offset	IHHTSD0080-125
80, 100, 125	Central	IHHTSDC080-125
125, 160, 200, 250	Central	IHHTSF0125-250
225, 250, 300, 315	Central	IHHTSK0225-315
400	Central	IHHTSMF400
400	Central	IHHTSMS400
400, 500	Central	IHHTTS0400-500
400, 500	Central	IHHTTM0400-500
630	Central	IHHTLM0630
800	Central	IHHTLM0800



DIN Type with Blade Contact	
Current Rating (A)	Cat. No.
6, 10, 16, 20, 25, 32, 40 50, 63, 80, 100	IHHCD11006-100
6, 10, 16, 20, 25, 32, 40 50, 63, 80, 100	IHHCD00006-100
125	IHHCD00125
160	IHHCD00160
32, 40, 50, 63, 80, 100, 125	IHHCD01032-125
160, 200	IHHCD01160-200
250	IHHCD01250
200, 250, 315	IHHCD02200-315
350, 400	IHHCD02350-400
425	IHHCD03425
500, 630	IHHCD03500-630



RH Type with Cylindrical Cap	
Current Rating (A)	Cat. No.
2, 4, 6, 10	IHHRH00002-10
16, 20, 25, 32, 40	IHHRH00016-40
50	IHHRH00050
63	IHHRH00063

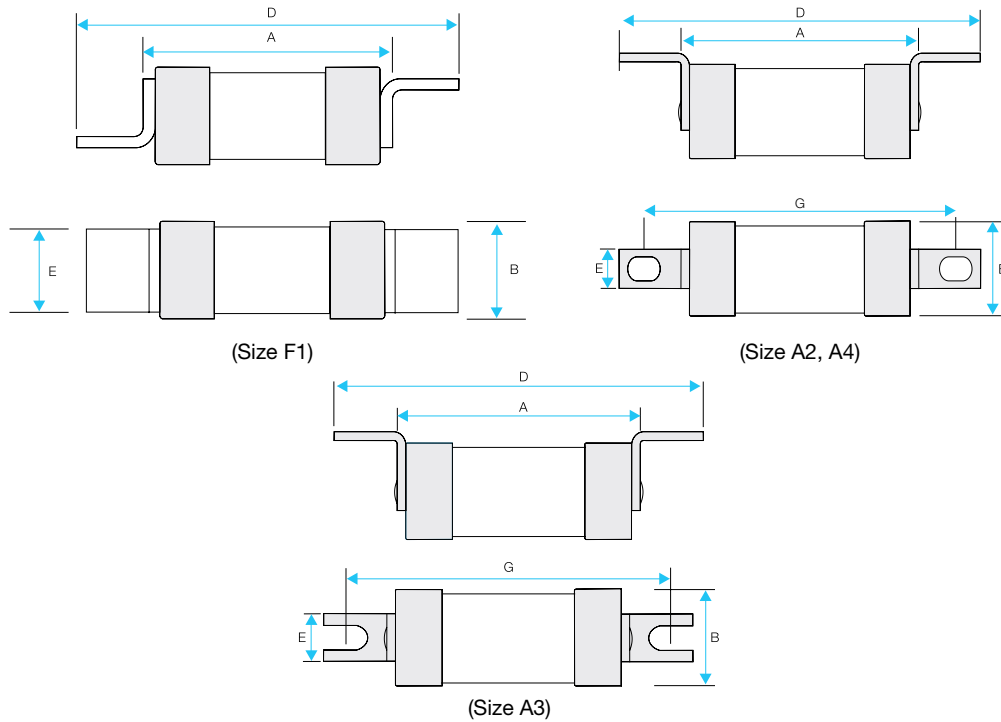

Dimensions (in mm) - BS Type with Bolted Connections

IS Size	Rating (Amp)	Cat. No.	A	B	D	E	G	L
F-1	2,4,6,10,16,20,25,32	IHHNS00002-032	33.5	13.4	60	11.5	-	-
A-2	2,4,6,10,16,20,25,32	IHHTIA0002-32	55	22	84.6	9	73	-
A-3	36, 40, 50, 63	IHHTSS0036-63	55	22	89.6	13	73	-
A-4	80, 100, 125	IHHTSD0080-125	56.5	24	109	19	94	-

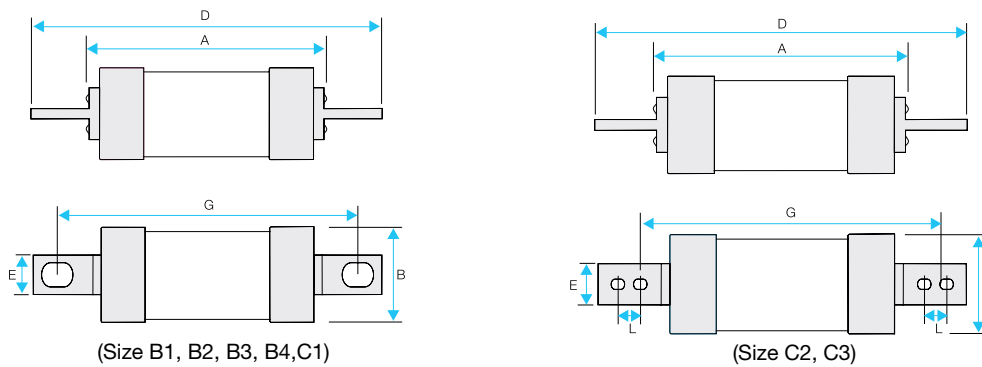

Dimensions (in mm) - BS Type with Bolted Connections

IS Size	Rating (Amp)	Cat. No.	A	B	D	E	G	L
B-1	80, 100, 125	IHHTSDC080-125	57	24	134	19	111	-
B-2	125, 160, 200, 250	IHHTSF0125-250	64	33	135	19	111	-
B-3	225, 250, 300-315	IHHTSK0225-315	72.6	39.5	134	25.4	111	-
B-4	400	IHHTSMF400	74.5	51.2	134	25.4	111	-
C-1	400	IHHTSMS400	75	51.2	156	25.4	133	-
C-2	400,500	IHHTTS0400-500	72.5	73	164	25.4	133	-
C-2	400, 500	IHHTTM0400-500	72	73	208	25.4	133	25.4
C-2	630	IHHTLM0630	72	73	208	25.4	133	25.4
C-3	800	IHHTLM0800	72	73	208	25.4	133	25.4

Dimensions (in mm)

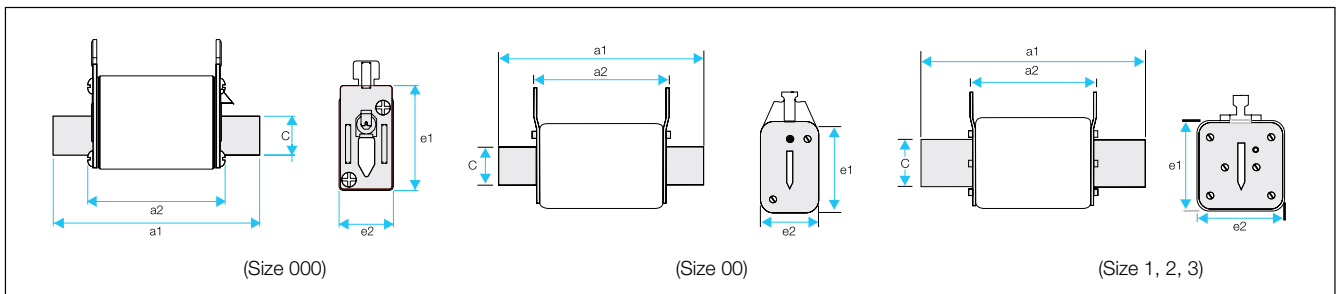

Din Type with Blade Contact							
IS Size	Rating (Amp)	Cat. No.	a ₁	a ₂	c	e ₁	e ₂
000	6,10,16, 20,25,40 32,50,63,80,100	IHHCD11***	78.5	52.6	15	40	20
00	6,10,16, 20,25,40 32,50,63,80,100,125,160	IHHCD00***	78.5	52.6	15	49	29.4
1	32,40,50,63,80,100 125,160,200,250	IHHCD01***	137	72	20	46	46
2	200,250,315,350,400	IHHCD02***	150	72	25	57	57
3	425,500,630	IHHCD03***	150	72	35	72	72

*** Rating

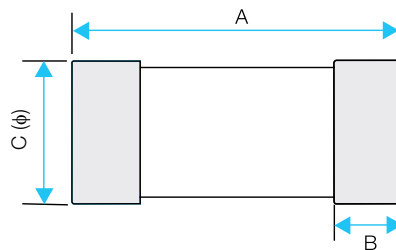

RH type with cylindrical cap				
Rating (A)	Cat. No.	A	B	C(φ)
2, 4, 6, 10, 16, 20, 25 32, 40, 50, 63	IHHRH	50.5	9.8	14.3

HiBreak DIN Fuse Bases

Features:

- Fibre glass reinforced Thermoplastic / Thermoset material provide excellent mechanical, thermal & electrical properties.
- Ease and Speed of installation - by Screws or on DIN Rail.
- Snap on mounting of phase barriers.

Type:

- Modular
- Fixed

HiBreak range of low voltage DIN fuse base have been designed to meet the requirements set for modern industrial installations & electrical power plants. Their breaking capacity is sufficient even for the highest short circuit levels, which are normally reached in practice.

DIN Type Fuse Base - Size 00, 1, 2 & 3 are designed for DIN Type Fuse Links upto 630A.

The Modular type Fuse Base is available in single pole. Two or more single pole can be connected side by side (straight or diagonally) into 2 pole and 3 pole configuration as per the customer requirement / availability of space.



Range :

100A to 630A.

Specification :

IEC 60269-1 & 2-1 / IS 13703-1 & 2-1.



Construction - Modular Type

Fibre glass reinforced thermoplastic material



Material of Base

Fibre glass reinforced thermoplastic material with high mechanical strength, thermal & electrical withstand.



Fixing by Screws



Fixing on DIN Rail

Mounting

By Screws for all sizes of fuse base & on DIN Rail (only for size 00)

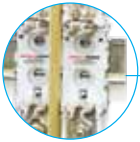

Snap on mounting of phase barriers

Phase Barriers

Snap on mounting phase barrier of insulating material to increase creepage distance & clearance between phases.

Fuse Contact



Fuse Contact

Current carrying contacts / terminals are made from precisely pressed copper material and are silver plated to ensure long life & non-deteriorating contact surface for high efficiency mating.

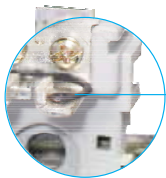

Pressure Circlip

Pressure Circlip

Pressure Circlip of spring steel material which do not loose its property at high temperature are suitably placed to ensure perfect mating of male - Fuse and female - Fuse Contact part and maintain sufficient pressure to ensure temperature rise is well within specified limits in continuous operation.

Size - DIN



Size 00



Size 1



Size 2



Size 3



Technical Data				
Type-Single Phase	IHMC00O160*	IHMC01O250	IHMC02O400	IHMC03O630
IEC Size -DIN	00	1	2	3
Size of Fuse Link	00	1	2	3
Accommodated Fuse Link Current	6A - 160A	32A - 250A	200A - 400A	425A - 630A
Rated Current of Fuse Base	160A	250A	400A	630A
Rated Voltage of Fuse Base	415VAC			
Rated Insulation Voltage	1000VAC			
Weight (Kg)	0.12	0.40	0.50	0.65

* Size 00 Fuse base is suitable for mounting both size 000 & size 00 fuse links.

Dimension (in mm)

Modular Type:

Side - 00
160A

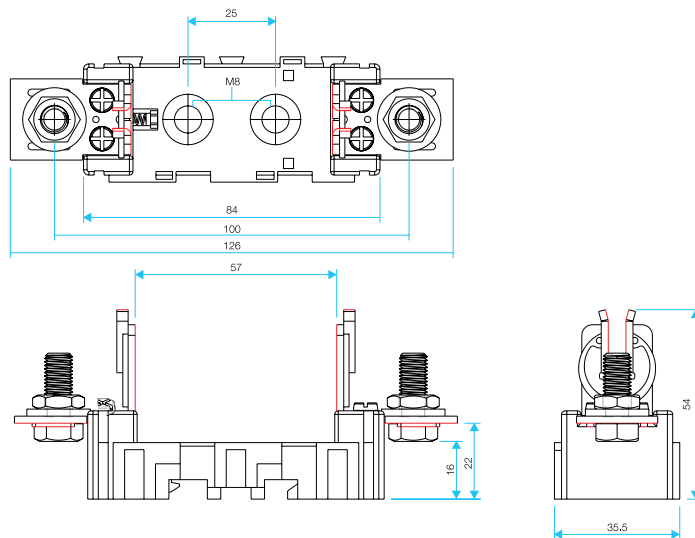

Side - 1 / 2 / 3
250A / 400A / 630A

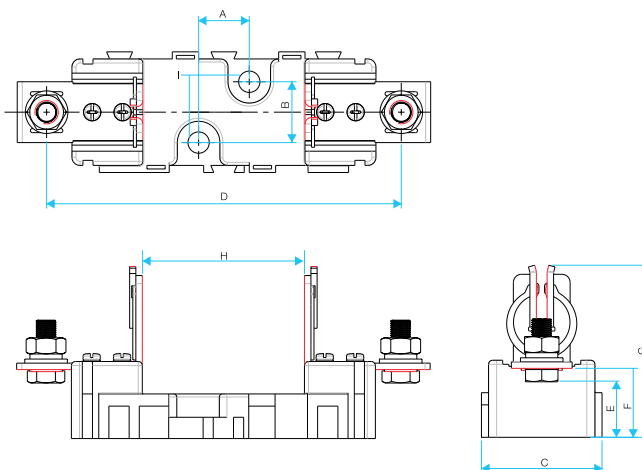

Dimension									
Size	A	B	C	D	E	F	G	H	I
1	25	30	59.5	175	27	34	84.9	80	M10
2	25	30	59.5	200	28	35	98	80	M10
3	25	30	59.5	210	29	36	109	80	M10

Construction - Fixed Type

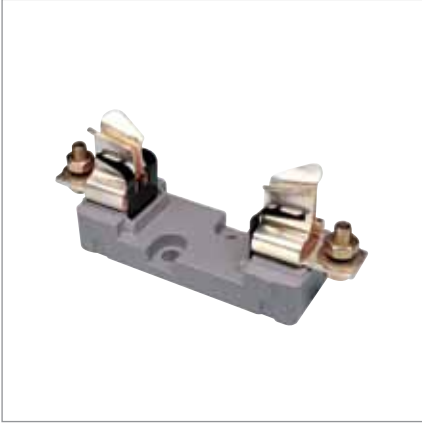

Moulding (Casing)

The Bases are manufactured from high grade thermosetting plastics. These are non-inflammable & non-hygroscopic.

Contacts

Current carrying parts of the holders are made from precisely pressed copper/brass material and have extruded brass base contacts. These are mounted on moulded seats to ensure perfect alignment. The current carrying parts of the fuse base are electro plated with silver to ensure long life & non-deteriorating contact surface for high efficiency mating.

Back up Clips

Back up pressure clips are precisely formed from Phosphor Bronze/Spring Steel material to ensure perfect mating of male and female parts for long life.

Terminals

Copper/Brass terminals are used for cable termination through Cable lugs for open type Fuse Bases complete with Cable holding fasteners.



Fuse Bases		
Current Rating (A)	Type	Cat. No.
100A	Open Fuse Base	IHUC000100
125A	Open Fuse Base	IHUC000125
160A	Open Fuse Base	IHUC000160
250A	Open Fuse Base	IHUC010250
400A	Open Fuse Base	IHUC020400
630A	Open Fuse Base	IHUC030630

Dimensions (in mm)

Fixed Type:

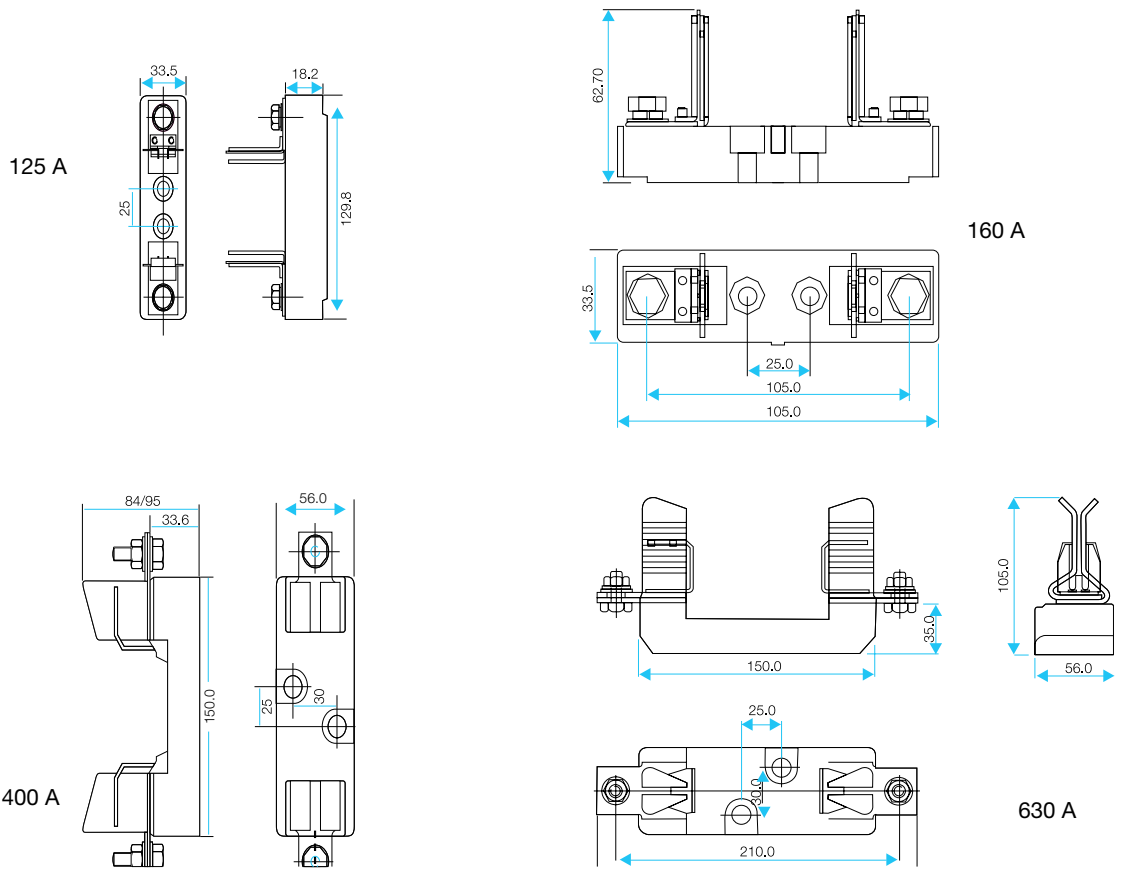

CamLock Fuse Holder

Features:

- Single case construction
- High breaking capacity withstand
- Smooth removal of fuse carrier with the fuse by CAM operated lever.
- Live parts completely shrouded.
- Dual termination facility for bus bar & cable connection.
- Three types of connection to suit different application needs.
- Provided with both DIN rail & screw mounting facility.
- Liberal terminal capacity.

Range :

20A, 32A, 63A & 100A in front connection, bus bar connection & rear connection versions.

Specification :

Conforms to IEC:60269-1 & 2-1 / IS: 13703-1 & 2-1

Fuse Holder consisting of carrier and base for mounting fuse links have been in use for long. Keeping operators' safety and ease / reliability of removal in mind, a complete range of unique CAM operated "Cam Lock Fuse Holder" are now offered to suit varied application for protection of distribution and motor circuits.





Housing :

Fuse holder is a combination of fuse base and fuse carrier. The base is a fixed part provided with terminals & shrouds and carrier is the movable part (designed to carry a fuse link) operated by a cam lever which engages the carrier mounted with the fuse to the fuse base. For removal of fuse, the lever is operated which disengages the carrier along with the fuse from the base thereby facilitating the removal of fuse from the carrier. The housing is made of thermo-plastic, flame retardant material having excellent thermal, mechanical & di-electric properties. It is a single case construction ensuring housing robustness.

Contacts :

Contacts are made of copper & silver for longer contact life, to increase the current carrying capacity and to ensure temperature rise is well within the specified limits.

Terminals :

The terminals are casted, silver plated and spring loaded. Current carrying parts are made of superior quality, cast brass and phosphor bronze.

Mounting :

The fuse holder is suitable for DIN rail (35mm x 7.5mm) mounting as per IS:11039. They are also suitable for panel mounting with M-5 screws / Bus bar mounting with brass nut.



Technical Information



Type			Front Connection	Bus Bar Connection	Rear Connection
Standard conformity			IS: 13703 (Part 2 sec. 1) : 1993 60269-2-1 : 2000-03		
Rated current (In)			20A, 32A, 63A, 100A	20A, 32A, 63A, 100A	20A, 32A, 63A, 100A
Rated voltage (Un)			415V AC*	415V AC*	415V AC*
Rated Insulation Voltage			660V AC	660V AC	660V AC
Rated Frequency			50Hz	50Hz	50Hz
No. of Pole			Single Pole	Single Pole	Single Pole
Rated power acceptance	FH-1	20A & 32A			
	FH-2	32A	4.4W	4.4W	4.4W
	FH-3	63A	6.9W	6.9W	6.9W
	FH-4	100A	9.1W	9.1W	9.1W
Rated peak withstand current		> 80KA			
Size of Fuse link	FH-1	20A & 32A	F1	F1	F1
	FH-2	32A	A2	A2	A2
	FH-3	63A	A3	A3	A3
	FH-4	100A	A4	A4	A4
Permissible ambient temperature			(-5°C to +55°C)	(-5°C to +55°C)	(-5°C to +55°C)
Mechanical durability			2000	2000	2000
Degree of protection			IP 20	IP 20	IP 20
Terminals capacity	FH-1	20A & 32A	10 sq.mm.	10 sq.mm.	10 sq.mm.
	FH-2	32A	35 sq.mm.	35 sq.mm.	35 sq.mm.
	FH-3	63A	35 sq.mm.	35 sq.mm.	35 sq.mm.
	FH-4	100A	50 sq.mm.	50 sq.mm.	50 sq.mm.
Dimensions (L x W x D)	FH-1	20A & 32A	74 x 25.5 x 45.5	74 x 25.5 x 45.5	74 x 25.5 x 45.5
	FH-2	32A	113 x 34.8 x 60	113 x 34.8 x 60	113 x 34.8 x 60
	FH-3	63A	113 x 34.8 x 60	113 x 34.8 x 60	113 x 34.8 x 60
	FH-4	100A	125 x 40.0 x 63.4	125 x 40.0 x 63.4	125 x 40.0 x 63.4
Net Weight	FH-1	20A & 32A	- (FC)	- (BB)	- (RC)
	FH-2	32A	0.224 kg	0.248 kg	0-.276 kg
	FH-3	63A	0.224 kg	0.248 kg	0-.276 kg
	FH-4	100A	0.338 kg	0.360 kg	0.380 kg

1. Fuse carrier suitable for offset tag fuse links only.
2. Fuse link size
 F1 (type of fuse HNS)
 A2 (type of fuse HTIA)
 A3 (type of fuse HTSS)
 A4 (type of fuse HTSD)

FC - Front connection
 BB - Bus Bar connection
 RC - Rear connection

Ordering Information

248



Front Connection				
Current Rating	Type of Fuse	Type of Connection		Cat. No.
		I/C	O/G	
20A	HNS	Cable	Cable	IHVONSH020
32A	HTIA	Cable	Cable	IHVTIAH032
63A	HTSS	Cable	Cable	IHVTSSH063
100A	HTSD	Cable	Cable	IHVTSDH100



Bus Bar Connection				
Current Rating	Type of Fuse	Type of Connection		Cat. No.
		I/C	O/G	
20A	HNS	Bus Bar	Cable	IHVONSB020
32A	HTIA	Bus Bar	Cable	IHVTIAB032
63A	HTSS	Bus Bar	Cable	IHVTSSB063
100A	HTSD	Bus Bar	Cable	IHVTSDB100



Rear Connection				
Current Rating	Type of Fuse	Type of Connection		Cat. No.
		I/C	O/G	
20A	HNS	Bus Bar	Bus Bar	IHVONSR020
32A	HTIA	Bus Bar	Bus Bar	IHVTIAR032
63A	HTSS	Bus Bar	Bus Bar	IHVTSSR063
100A	HTSD	Bus Bar	Bus Bar	IHVTSDR100

Dimensional Details (in mm)

Fuse Link Size A2, A3, A4

HBC Fuse Holders-Bolted Type Size A2 & A3, A4

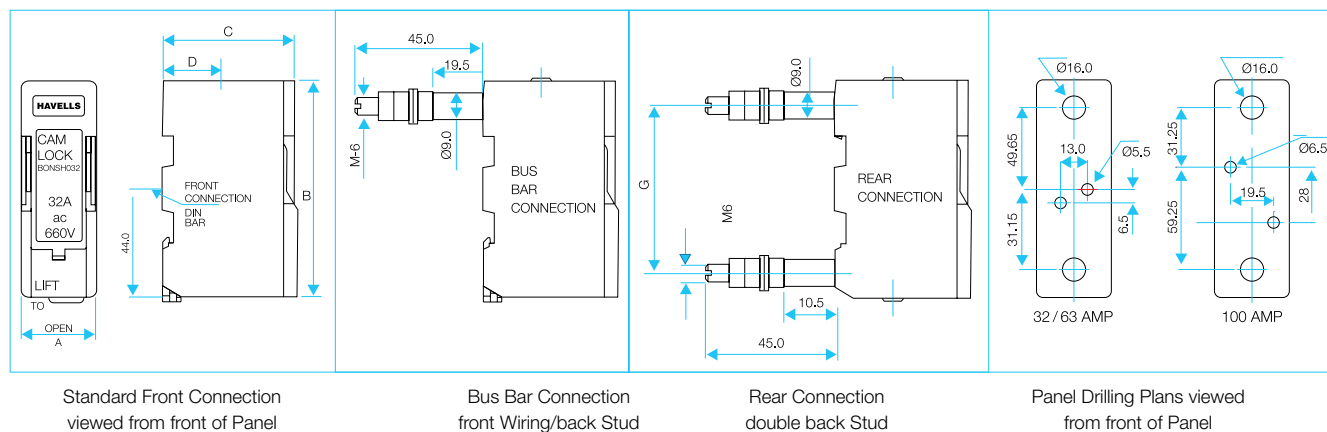

Description	Cat.No.	Max Voltage Rating (ac)	A	B	C	D	G	Fuse Type
32A HRC FF Cam Lock Front Connection	IHVTIAH032	660V	34.8	113	60.0	21.2	80.8	HTIA
32A HRC FF Cam Lock BUS BAR Connection	IHVTIAB032	660V	34.8	113	60.0	21.2	80.8	HTIA
32A HRC FF Cam Lock Rear Connection	IHVTIAR032	660V	34.8	113	60.0	21.2	80.8	HTIA
63A HRC FF Cam Lock Front Connection	IHVTSSH063	660V	34.8	113	60.0	21.2	80.8	HTSS
63A HRC FF Cam Lock BUS BAR Connection	IHVTSSB063	660V	34.8	113	60.0	21.2	80.8	HTSS
63A HRC FF Cam Lock Rear Connection	IHVTSSR063	660V	34.8	113	60.0	21.2	80.8	HTSS
100A HRC FF Cam Lock Front Connection	IHVTS DH100	660V	40.0	125	63.4	23.0	90.5	HTSD
100A HRC FF Cam Lock BUS BAR Connection	IHVTSDB100	660V	40.0	125	63.4	23.0	90.5	HTSD
100A HRC FF Cam Lock Rear Connection	IHVTS DR100	660V	40.0	125	63.4	23.0	90.5	HTSD

HBC FUSE HOLDERS-Bolted Type Size F1

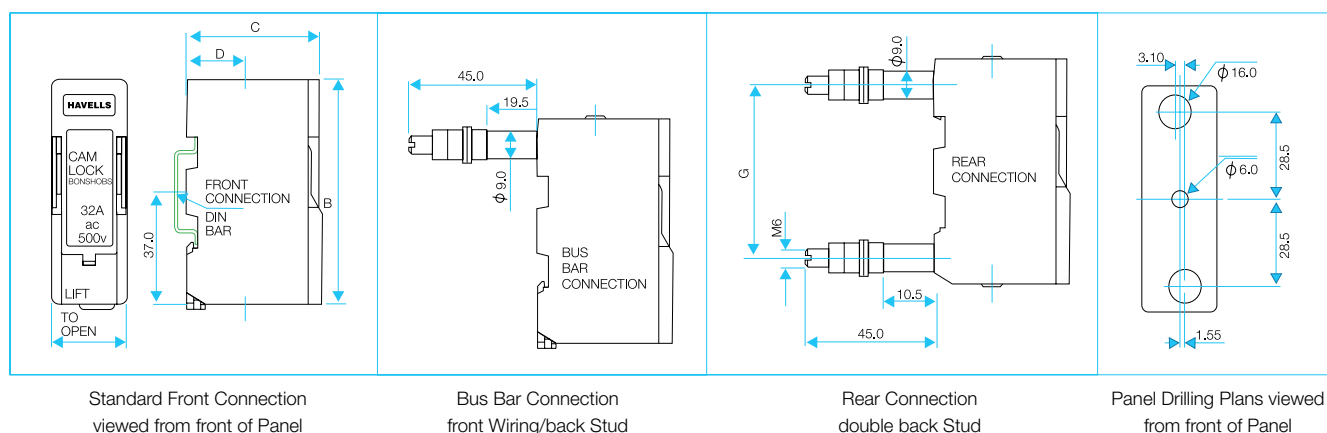

Description	Cat.No.	Max Voltage Rating (ac)	A	B	C	D	G	Fuse Type
32A HBC FF Cam Lock Front Connection	IHVONSH032	500V	25.5	74	45.5	19	57.0	HNS
32A HBC FF Cam Lock Bus Bar Connection	IHVONSB032	500V	25.5	74	45.5	19	57.0	HNS
32A HBC FF Cam Lock Rear Connection	IHVONSR032	500V	25.5	74	45.5	19	57.0	HNS

Busbar Chamber System

Features:

- Readymade & customised solution for safe power distribution
- Modular/compact design provides economy of space and cost
- Simple and efficient system configuration
- Easy, flexible and time saving installation
- Shock proof design
- Elegant & sleek in appearance

Range :

The busbar chambers are available for 100A/200A, 250A/315A/400A & 630A/800A current ratings with short circuit withstand capacity of 25kA, 35kA & 50kA respectively. These are offered in 4 way, 6way & 8 way in Four Pole configuration.

Specification :

Fully application oriented as per
IS:8623/IEC 60439 (Panel sub assemblies)
IS: 2147/IEC60529 (Degree for protection)

Havells BUSBAR CHAMBER system is designed for safe, reliable & economical distribution of power to various loads as per the requirements of the system. The modular construction of the bus bar chamber provides for compact & easy add-on modules on the basic unit for system expansion (if the need be). These can be wall mounted and can also be made suitable for floor mounting by using optional pedestal set.



Application :

The busbar chambers find wide application in power distribution in areas namely :

- Construction site
- Shop floor
- Multi-storeyed complexes
- Building installation etc.

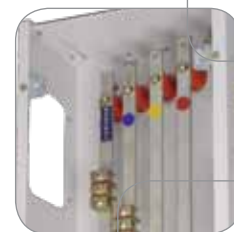

The busbar chamber is fabricated using sheet steel (CRCA) of 1.6mm thickness and epoxy powder coated to give superior & lasting finish. The bus bar sections are made of ETP grade copper & dull tin plated and the bus bar supports are made of DMC (Dough moulding compound). The neutral bus bar is fully rated.

In bus bar chambers upto 200A, the bus bar layout is in a single layer (i.e. one by the side of the other & duly separated/supported on the bus bar support). Whereas in bus bar chambers of 250A / 315A / 400A / 630A / 800A, the busbar layout is in form of stack (i.e. one bus bar behind the other duly separated/supported by bus bar support). All have detachable end plates enabling them to be extended easily with the connection of another chamber. Full top and bottom end plates are detachable.

Kit comprising of connecting copper links are available for extending the busbar section in the add on module.



63A / 200A



250A / 800A

Technical Information				
Frame	63A	200A	400A	800A
Standard Conformity	IEC-60439/IS-8623 IEC-60529/IS-2147	IEC-60439/IS-8623 IEC-60529/IS-2147	IEC-60439/IS-8623 IEC-60529/IS-2147	IEC-60439/IS-8623 IEC-60529/IS-2147
Incoming Current Rating (A)	63	100, 200	250,315,400	630,800
Operational Voltage - Frequency (V / Hz)	415 - 440 / 50	415 - 440 / 50	415 - 440 / 50	415 - 440 / 50
Insulation Voltage (V)	1000	1000	1000	1000
Execution (No. of Poles)	FP	FP	FP	FP
Short Circuit withstand Capacity (1 Sec., KA)	10	25	35	50
Outgoing (No. of Ways)	4,6, 8	4,6, 8	4,6,8	4,6,8
Degree of Protection	IP-31	IP-31	IP-31	IP-31
Busbar Layout	Single layer (side by side)		Stack layer (one behind the other)	

Ordering Information



Front Connection		
Current Rating	No. of ways	Cat. No. Wall Mounted
63A	4 way	IHBB006304
	6 way	IHBB006306
	8 way	IHBB006308
100A	4 way	IHBB010004
	6 way	IHBB010006
	8 way	IHBB010008
200A	4 way	IHBB020004
	6 way	IHBB020006
	8 way	IHBB020008
250A	4 way	IHBB025004
	6 way	IHBB025006
	8 way	IHBB025008
315A	4 way	IHBB031504
	6 way	IHBB031506
	8 way	IHBB031508
400A	4 way	IHBB040004
	6 way	IHBB040006
	8 way	IHBB040008
630A	4 way	IHBB063004
	6 way	IHBB063006
	8 way	IHBB063008
800A	4 way	IHBB080004
	6 way	IHBB080006
	8 way	IHBB080008

* Accessories - connecting copper links to extend the bus bar section in the add-on module.

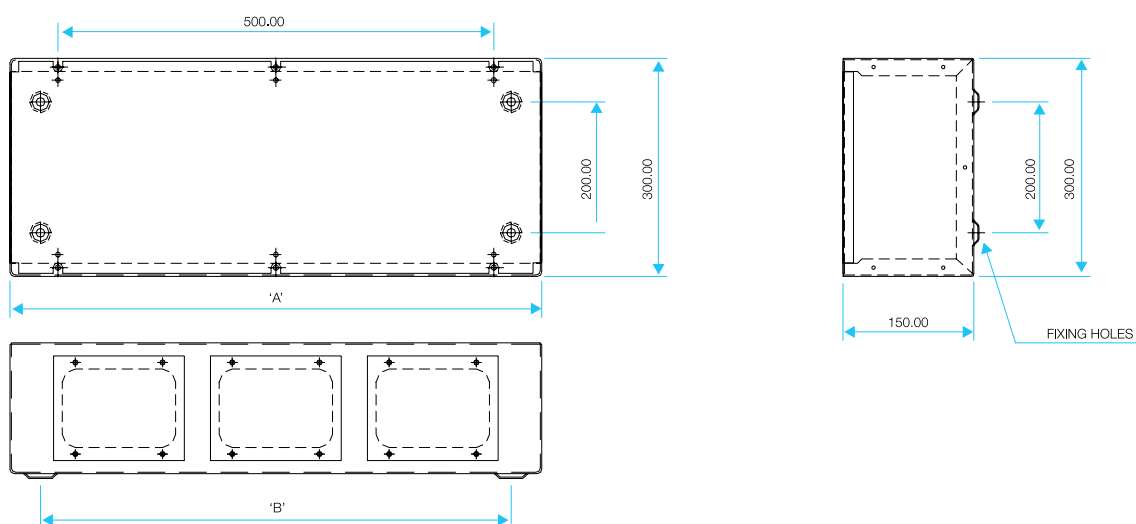

Dimension (mm) Frame - 63A		
No. of Ways	Dimn. 'A'	Dimn. 'B'
4 Way TPN	450	360
6 Way TPN	630	540
8 Way TPN	810	720

Dimension (mm) Frame - 200A

No. of Ways	Dimn. 'A'	Dimn. 'B'
4 Way TPN	450	360
6 Way TPN	630	540
8 Way TPN	810	720

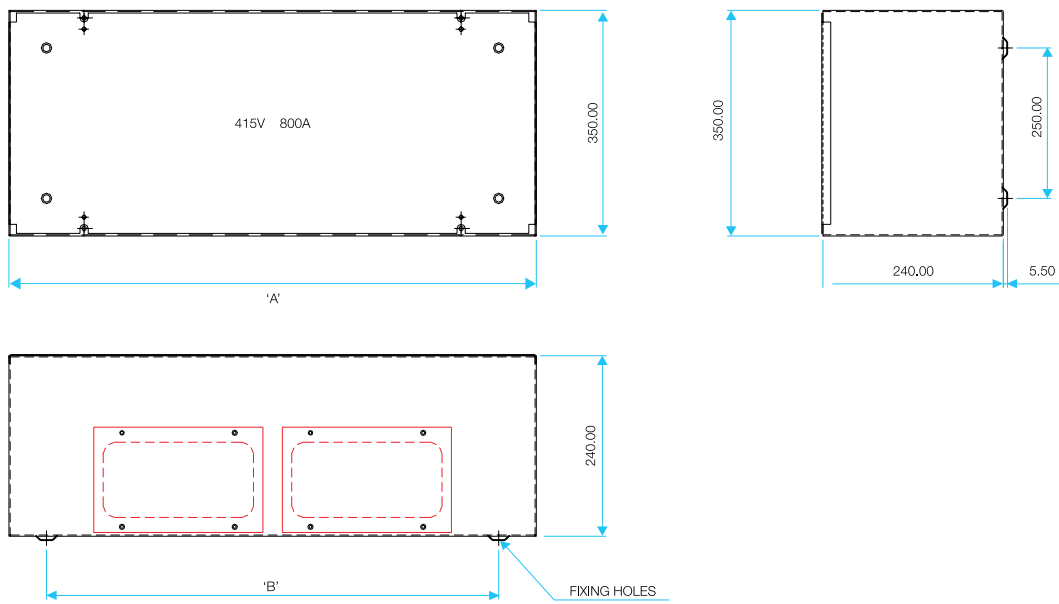

Dimension (mm) Frame - 400A / 800A

Busbar Chamber - Main - 400A & O / G - 200A		
No. of Ways	Dimn. 'A'	Dimn. 'B'
4 Way TPN	700	600
6 Way TPN	950	850
8 Way TPN	1200	1100

Illustration

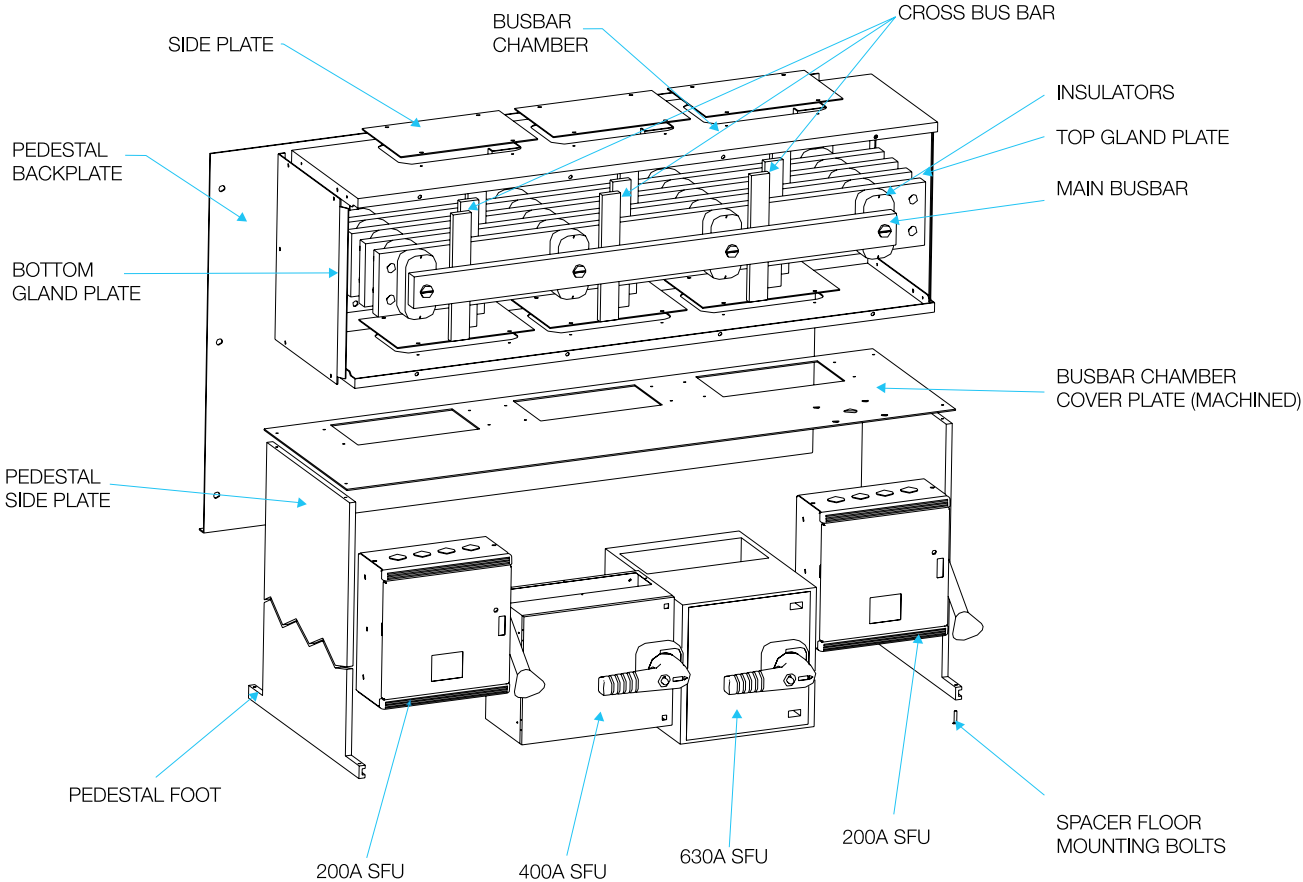

*Supply of Busbar Chamber is in our scope, the mounting shown are for illustration purpose only.

Load Changeover Switch

Features:

- Suitable for individual mounting, inner mounting holes and mounting brackets provided in enclosures.
- Sheet steel enclosure duly phosphatised and powder painted for longer life.
- Provision for door interlocking.
- Termination suitable for Aluminum cables, adequate knockouts provided in the enclosure for cable entry.

Range :

Onload Changeover Switch - AC 23 (side handle)

- 32A, 63A, 240V in Double Pole version
- 32A-100A, 415V in Three Pole version
- 16A-100A, 415V in Four Pole version

Offload Changeover Switch - AC 20A (side handle)

- 200A-2000A, 415V in Four Pole version

Specification :

Conforms to IS / IEC:60947-1&3

A comprehensive range of General Purpose Load Changeover Switches with side handle operation find wide application in all general industries where individual system require safe and reliable transfer of power from main supply to standby supply and vice versa.

Load Changeover Switches are supplied in Sheet Steel enclosure, side operated with three stable positions; I-O-II, (centre-off position).



General Purpose

Load Changeover Switch





Contacts

Contacts are made of electrolytic copper, silver plated for long contact life, increased current carrying capacity and to ensure temperature rise within permissible limits.

Operating Handle and Interlocking

The operating handle is made of steel and is provided on the right hand side of the switch enclosure. Door interlock ensures the door cannot be opened when the switch is in ON position thereby providing safety.

Terminal Blocks

Terminal blocks are provided for cable termination. These are made of DMC/Porcelain which has excellent mechanical, thermal and dielectric properties.

Enclosure:

The enclosure is made of sheet steel suitable for individual mounting. They are provided with adequate knockout for cable entry and inner mounting holes for switch ratings upto 320A and mounting brackets for switch rating of 400A and above.



Double Pole Onload Changeover Switch AC 23 (side handle)	
Current Rating (A)	Cat. No.
32	IHCFDE0032
63	IHCFDE0063



Three Pole Onload Changeover Switch AC 23 (side handle)	
Current Rating (A)	Cat. No.
32	IHCFTE0032
63	IHCFTE0063
100	IHCFTE0100

General Purpose

Load Changeover Switch



Four Pole Load Changeover Switch	
Onload Changeover Switch - AC 23A (side handle)	
Current Rating (A)	Cat. No.
16	IHCFFE0016
32	IHCFFE0032
63	IHCFFE0063
100	IHCFFE0100
Offload Changeover Switch - AC 20A (side handle)	
Current Rating (A)	Cat. No.
200	IHCFFE0200
320	IHCFFE0320
400	IHCFFE0400
630	IHCFFE0630
800	IHCFFE0800
1000	IHCFFE1000
1250	IHCFFE1250
1500	IHCFFE1500
2000	IHCFFE2000

259

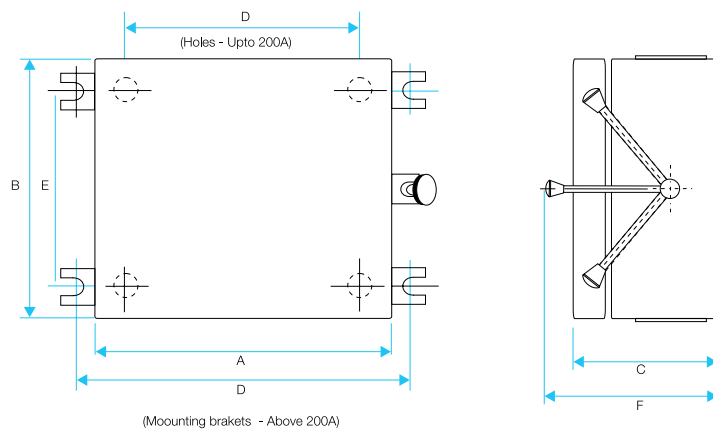

Dimensions (in mm)									
Rating	A	B	C	D	E	F	Size for Cable entry & exit	Size of Al. conductor	Size of knock-out
Double Pole 32A	136	205	100	76	140	155	--	16 mm ²	25.4φ
63A	210	217	100	166	173	165	--	25 mm ²	25.4φ
Three Pole 32A	210	217	100	166	173	165	--	16 mm ²	25.4φ
63A	270	318	134	205	236	205	--	25 mm ²	38φ
100A	316	320	141	254	258	240	282x60	50 mm ²	38φ
Four Pole 16A	210	217	100	166	173	165	--	4 mm ²	25.4φ
32A	210	217	100	166	173	165	--	16 mm ²	25.4φ
63A	270	318	134	205	236	205	--	25 mm ²	38φ
100A	400	320	138	338	260	245	366x60	50 mm ²	38φ
200A	425	495	250	322	390	400	--	150 mm ²	
320A	425	495	250	322	390	400	--	240 mm ²	
400A	515	594	302	545	484	418			
630A	605	595	310	640	480	505			
800A	605	595	310	640	480	505			
1000A	730	700	348	780	535	--			
1250/1500A	1155	688	440	1205	438	680			
2000A	1250	760	520	1270	545	770			

Fuse Switch & Switch Fuse

Features:

Fuse Switches

- Double break with side handle operation
- Positive indication of contacts
- Suitable for surface mounting
- Door interlock facility
- Sheet steel enclosure duly phosphatised and powder painted

Switch Fuses

- Side handle operation
- Suitable for surface mounting
- Sheet steel enclosure duly phosphatised and powder painted
- Provision of conduit knockouts and detachable gland plates.

Range :

Fuse Switch : 63A to 800A in TPN & FP Execution

Switch Fuse : 16A to 63A in SPN / DP Execution
16A to 320A in TPN Execution

Specification :

Conforms to IS / IEC:60947-1&3

A complete range of Fuse Switch & Switch Fuse units are offered to suit varied power distribution applications. The heavy duty Fuse Switches are fully type tested with short circuit breaking capacity of 80 KA at 415V suitable for utilisation category AC-22A/AC-23A. Four frame sizes cover the full range.

The Switch Fuse units are suitable for utilisation category AC-22A.



General Purpose

Fuse Switch & Switch Fuse

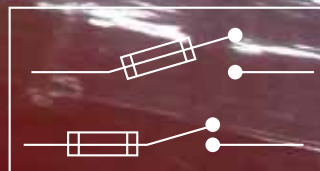



Fuse Switch

Fuse Switch units are fitted with sturdy side operating handle which drives the quick make-break mechanism incorporating operating springs. Liberal sized silver plated terminals, suitable for aluminium cable/bus-bar termination, are provided with terminal cover shields to prevent any accidental contact with live metal parts. Positive ON-OFF indication is provided on the switch door.

Contacts

Contacts are made of electrolytic copper, electro-plated with silver, for better contact and greater resistance to corrosion. Specially designed female contacts ensure low contact resistance and better arc-control.

Fuses

Fuse switches are designed for use with HBC Cartridge fuselinks conforming to IS:13703.

Enclosures

The enclosure is made of sheet steel, rust protected, phosphatized and powder coated. They are fitted with removable top and bottom end plates provided with knock-outs for bus bars/cables entry. Front accessible door, fitted with dust-excluding gasket, is interlocked to prevent opening when the switch is in 'ON' condition. They are suitable for surface mounting.



Switch Fuse

Switch Fuse Unit comprises of vitreous steatite porcelain rewirable fuses or HBC fuse fittings complete with their conducting parts. The switch is fitted with sturdy side operating handle with quick make-break type mechanism.

Contacts

Contacts are made of electrolytic copper, silver-plated. The fixed contacts are provided with removable shield.

Fuses

Switch Fuse units are provided with rewirable fuse or HBC Fuse Links.

Enclosures

The Enclosure is made of sheet steel duly phosphatised and power-coated. They are provided with conduit knock-outs and have detachable gland plates. Door interlock is provided to prevent opening when the switch is in 'ON' condition.

General Purpose

Fuse Switch & Switch Fuse



Technical Information - Fuse Switch						
Rating Thermal	AC-23 Isolating Switch rating	AC-22 Fuse Switch rating	AC-23 Fuse Switch rating	Suggested Fuse Type	AC-23 Motor Switch rating	Mechanical Endurance (Operating cycles)
63A	80A	80A	63A	H TS	28 KW	10,000
100A	125A	125A	100A	H TSD	45 KW	10,000
160A	200A	200A	160A	H TSF	80 KW	8,000
200A	250A	250A	200A	H TSF	90 KW	8,000
320A	400A	320A	320A	H TSK	150 KW	5,000
400A	500A	460A	400 A	H TSMF	185 KW	5,000
500A	630A	630A	500A	H TTM	225 KW	5,000
800A	800A	750A	630A	H TLM	300 KW	3,000



Technical Information - Switch Fuse							
Rating	Short Time with Stand Current (1 sec)	Short Circuit Making Capacity	Rated fused Short Circuit Current	Switch Rating at 415V, AC		AC-23 Motor Rating	Recommended Fuses (for Non-rewirable types)
				AC-21	AC-22		
16A	700A	4.6 KA	45 KA	20A	16A	5.5 KW	HNS
32A	1200A	7.2 KA	45 KA	32A	32A	11 KW	HTIA
63A	2200A	8.4 KA	65 KA	80A	80A	22 KW	HTIA/HTSS
100A	4000A	9.8 KA	65 KA	125A	100A	41 KW	HTSD
200A	--	--	--	200A	--	55 KW	--
320A	--	--	--	320A	--	70 KW	--



Switch Fuse Unit (Rewirable Type) SPN & DP

Current Rating (Amps/Volts)	SPN Cat. No.	DP Cat. No.
16/240	IHSRSE2016	IHSRDE2016
32/240	IHSRSE2032	IHSRDE2032
63/415	IHSRSE4063	IHSRDE4063



Switch Fuse Unit (Rewirable Type) TPN

Current Rating (A)	Rewireable Porcelain Fuse Units Cat No.	HBC cum Rewirable Porcelain Fuse Units Cat No.	Bakelite Fuse Fittings (without HBC Fuse Links) Cat No.
16	IHSRTE4016	IHSHTe4016	IHSBTE4016
32	IHSRTE4032	IHSHTe4032	IHSBTE4032
63 (Standard)	IHSRTE4063	--	--
63 (Deluxe)	IHSDTE4063	IHSHTe4063	IHSBTE4063
100 (Standard)	IHSRTE4100	--	--
100 (Deluxe)	IHSDTE4100	IHSHTe4100	IHSBTE4100
200	IHSRTE4200	--	--
320	IHSRTE4320	--	--



Fuse Switch Unit - HBC Fuse Type

Current Rating (A)	TPN Cat. No.	FP Cat. No.
63	IHFNTW4063	IHFNFw4063
100	IHFNTW4100	IHFNFw4100
160	IHFNTW4160	IHFNFw4160
200	IHFNTW4200	IHFNFw4200
320	IHFNTW4320	IHFNFw4320
400	IHFNTW4400	IHFNFw4400
500	IHFNTW4500	--
800*	IHFNTW4800	--

*Switch suitable for 800 Amp. but fitted with 630Amp. Fuse.

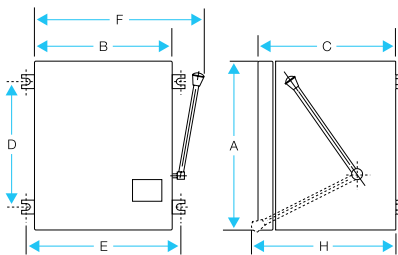

Dimensions (in mm) - Fuse Switch Unit, TPN

Rating	A	B	C	D	E	F	G	H	Size for Cable entry & exit	Size of Al. conductor	Size of knock-out
63/415	292	270	237	244	328	340	--	270	235x80	35mm ²	25φ/31φ
100/415	292	270	237	244	328	340	--	270	235x80	70mm ²	25φ/31φ
160/415	360	350	339	312	408	435	--	360	295x140	185mm ²	--
200/415	360	350	339	312	408	435	--	360	295x140	185mm ²	--
320/415	360	350	339	312	408	435	--	360	295x140	350mm ²	--
400/415	360	350	339	312	408	435	--	360	295x140	2(32x10)*	--
500/415	360	430	339	312	488	535	--	380	295x140	2(40x10)*	--
800/415	480	498	408	433	556	605	--	425	428x183	1(50x10)*	--

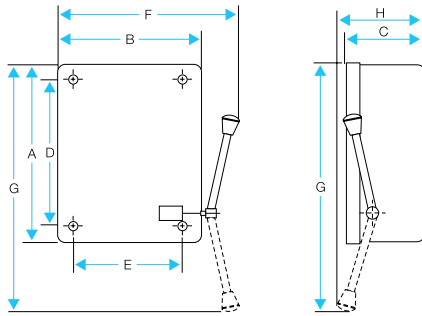

16A - 63A (Deep Drawn Enclosure)

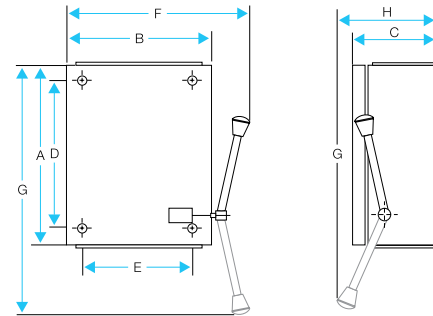

63A - 320A (Fabricated Enclosure)

Dimensions (in mm) - Switch Fuse Units

Rating	A	B	C	D	E	F	G	H	Size for Cable entry & exit	Size of Al. conductor	Size of knock-out
SPN/DP Rew											
16/240	145	95	55	110	60	130	180	--	--	4 mm ²	19φ
32/240	220	140	75	166	85	180	285	--	--	6 mm ²	25φ
TP Rew/HBC-Rew/BFF											
16/415	225	175	75	172	123	210	285	--	--	6 mm ²	25φ
32/415	260	205	82	213	171	260	315	--	--	16 mm ²	25φ
DP Rew/HBC-Rew/BFF											
32/415	265	215	85	213	171	260	315	--	--	16 mm ²	25φ
63/415	278	210	116	213	128	250	380	160	--	35mm ²	25φ/31φ
TP Rew / BFF											
32/415	265	215	85	213	171	260	315	--	--	16 mm ²	25φ
63/415	265	215	85	213	171	260	315	--	--	35 mm ²	25φ
100/415	347	310	120	285	248	380	435	170	--	70mm ²	25φ/31φ
Rew. T.P. / STD											
63/415	280	270	116	223	205	325	390	175	--	35mm ²	25φ/31φ
100/415	347	310	120	285	248	380	435	170	--	70mm ²	25φ/31φ
DLX. TP / HBC cum Rew											
63/415	350	280	120	288	218	360	445	160	246x61	35mm ²	25φ/31φ
100/415	400	330	150	338	268	400	490	160	296x80	70mm ²	25φ/31φ
TP Rew											
200/415	554	315	160	450	215	385	565	260	280x97	185mm ²	38φ
320/415	565	398	182	465	298	475	585	260	363x104	300mm ²	38φ

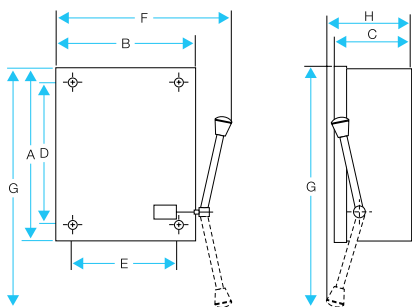

Fabricated Enclosure

Dimensions (in mm) - Isolator Switch TPN

Rating	A	B	C	D	E	F	G	H	Size for Cable entry & exit	Size of Al. conductor	Size of knock-out
16/415	167	207	80	121	163	250	220	100	174x30	6mm ²	25φ/31φ
32/415	167	207	80	121	163	250	220	100	174x30	16mm ²	25φ/31φ
63/415	238	310	125	176	248	365	345	160	275x60	35mm ²	25φ/31φ
100/415	238	310	125	176	248	365	345	160	275x60	70mm ²	25φ/31φ

Other Products

Building Circuit Protection

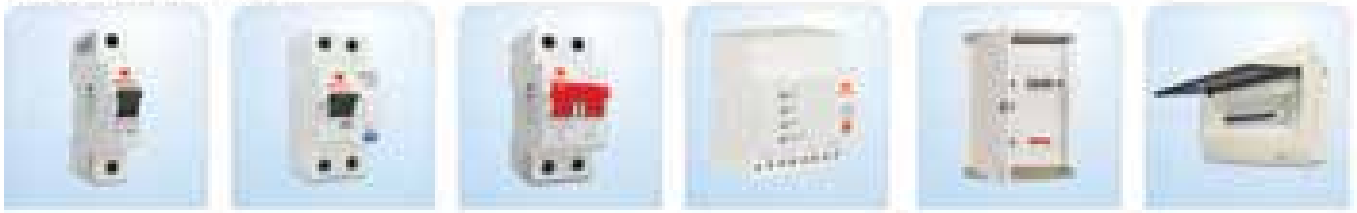

Compact Fluorescent Lamp (CFL)



Luminaires

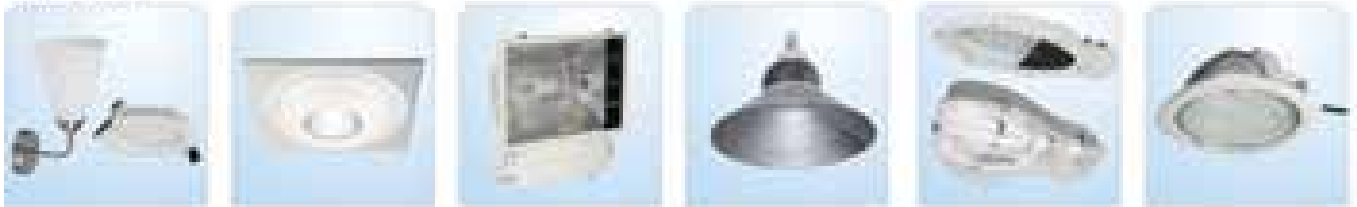

Fans & Domestic Appliances

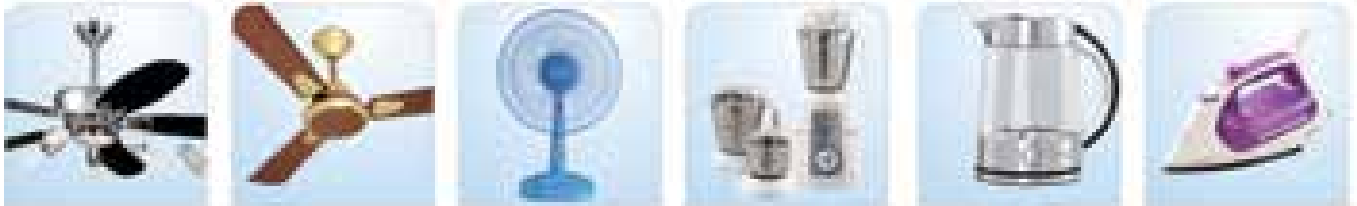

Power & Flexible Cables



Industrial Circuit Protection



APFC & PFC



Capacitors



Switches

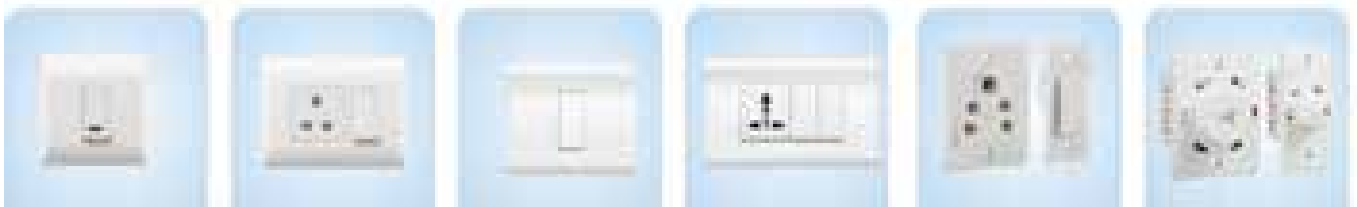

REGIONAL BRANCH OFFICES

NORTH - REGIONAL OFFICE: Corporate Office: QRG Towers, 2D, Sector-126, Expressway, Noida-201304, Tel: 0120-3331000,

Delhi: Tel: 011-47676700, 23888200,

Chandigarh: Tel: 0172-4232400-401,

Dehradun: Tel: 0135-6670202,

Noida / Haryana: Tel: 0120-3331000,

Ludhiana: Tel: 0161-4676000 / 24,

Jammu: Tel: 0191-2490424,

Sri Nagar: Tel: 0194-2490431,

Jaipur: Tel: 0141-3914645, 3988210

Jodhpur: Tel: 0291-9214201640 / 45,

Lucknow: Tel: 0522-6672100,

Kanpur: Tel: 0512-6710400, 6710409

EAST - REGIONAL OFFICE: Kolkata: ICC Tower, 5th Floor, 4 India Exchange Place, Kolkata-700001, Tel: 033-40129851 / 52,

Bhubaneshwar: Tel: 0674-6668101/102/103/104,

Guwahati: Tel: 0361-2134521, 2458923, 2460355,

Siliguri: Tel: 0353-2525907,

Ranchi: 0651-2244861, 2244862, 2244864, 2244868, 2244869,

Jamshedpur: Tel: 0657-6542492, 09234369436,

Patna: Tel: 0612-2207221, 2207222, 2207223, 2655518

WEST - REGIONAL OFFICE: Mumbai: 301, Everest House, 3rd Floor, 6, Suren Road, Chakala,

Andheri (E). Mumbai - 400 093, Tel: 022-67298600-602,

Ahmedabad: Tel: 079-40061111, 40060738-740,

Indore: Tel: 0731-2572340-41, 4009998 (Airtel),

Rajkot: Tel: 0281-2481112, 2921212,

Nagpur: Tel: 0712-2240932, 2242692, 2242699

Pune: Tel: 020-64016413 / 14,

Raipur: Tel: 0771-4243400 / 01,

Surat: Tel: 0261-2350137, 9979890137,

Jabalpur: Tel: 0761-4064491

SOUTH - REGIONAL OFFICE: Chennai: Sigapi Achi Building, No. 18 / 3, 6th Floor,

Rukmani Lakshmi pathy Road, Egmore, Chennai-600008, Tel: 044-42280600, 605,

Bangalore: Tel: 080-49075000,

Coimbatore: Tel: 0422-2305767, 2306199, 2305199,

Hyderabad: Tel: 040-27533372, 27533355, 27533632, 66320407/0408/6401/6402,

Kochi: Tel: 0484-4099000,

Vishakapatnam: Tel: 0891-6514339,

Vizag: Tel: 0891-6514339,

Vijayawada: Tel: 91+9247058847/57,

Calicut: 09895855499,

Madurai: 09994493242,

Trivandrum: 09633817795,

Hubli: 09448146028,

Trichy: 09944460160

REPRESENTATIVE OFFICES

• Goa • Solapur • Gwalior • Kathmandu • Bhopal

Although every effort has been made to ensure accuracy in the compilation of the technical detail within this publication. Specifications and performance data are constantly changing. Current details should therefore be checked with Havells Group.

SW/ZIP00001/MAR15/MAY 15

Scan the QR Code
to download
Havells mCatalogue



Havells India Ltd.

QRG Towers, 2D, Sector -126, Expressway, Noida - 201 304 (UP), Ph. +91-120-3331000,
E-mail: marketing@havells.com, www.havells.com
Consumer Care No.: 1800 11 0303, 1800 103 1313 (All Connections), 011-4166 0303 (Landline)
Join us on Facebook at www.facebook.com/havells and share your ways to save the planet!
CIN - L31900DL1983PLC016304.

